

STATE OF NORTH CAROLINA
DEPARTMENT OF TRANSPORTATION
RALEIGH, N.C.

C204130

CONTRACT AND
CONTRACT BONDS

FOR CONTRACT NO. C204130

WBS

17BP.14.R.154, 50192.3.1 STATE FUNDED

T.I.P NO.

R-5734A

COUNTY OF

MACON

THIS IS THE

ROADWAY & STRUCTURE CONTRACT

ROUTE NUMBER

US 23

LENGTH

1.113 MILES

LOCATION

US-23/441 FROM US-64 TO SR-1652 (WIDE HORIZON DR)/SR-1152
(BELDEN CIR) & BRIDGE NO. 314 OVER CARTOOGECHAYE CREEK.

CONTRACTOR

BUCHANAN AND SONS INC

ADDRESS

,

BIDS OPENED

NOVEMBER 20, 2018

CONTRACT EXECUTION

12/16/2018

STATE OF NORTH CAROLINA
DEPARTMENT OF TRANSPORTATION
RALEIGH, N.C.

PROPOSAL

INCLUDES ADDENDUM No. 2 DATED 11-14-2018

INCLUDES ADDENDUM No. 1 DATED 11-06-2018

DATE AND TIME OF BID OPENING: **NOVEMBER 20, 2018 AT 2:00 PM**

CONTRACT ID C204130
WBS 17BP.14.R.154, 50192.3.1

FEDERAL-AID NO. STATE FUNDED

COUNTY MACON

T.I.P. NO. R-5734A

MILES 1.113

ROUTE NO. US 23

LOCATION US-23/441 FROM US-64 TO SR-1652 (WIDE HORIZON DR)/SR-1152
(BELDEN CIR), & BRIDGE NO. 314 OVER CARTOOGECHAYE CREEK.

TYPE OF WORK GRADING, DRAINAGE, PAVING, SIGNAL, CULVERT, AND STRUCTURE.

NOTICE:

ALL BIDDERS SHALL COMPLY WITH ALL APPLICABLE LAWS REGULATING THE PRACTICE OF GENERAL CONTRACTING AS CONTAINED IN CHAPTER 87 OF THE GENERAL STATUTES OF NORTH CAROLINA WHICH REQUIRES THE BIDDER TO BE LICENSED BY THE N.C. LICENSING BOARD FOR CONTRACTORS WHEN BIDDING ON ANY NON-FEDERAL AID PROJECT WHERE THE BID IS \$30,000 OR MORE, EXCEPT FOR CERTAIN SPECIALTY WORK AS DETERMINED BY THE LICENSING BOARD. BIDDERS SHALL ALSO COMPLY WITH ALL OTHER APPLICABLE LAWS REGULATING THE PRACTICES OF ELECTRICAL, PLUMBING, HEATING AND AIR CONDITIONING AND REFRIGERATION CONTRACTING AS CONTAINED IN CHAPTER 87 OF THE GENERAL STATUTES OF NORTH CAROLINA. NOTWITHSTANDING THESE LIMITATIONS ON BIDDING, THE BIDDER WHO IS AWARDED ANY FEDERAL - AID FUNDED PROJECT SHALL COMPLY WITH CHAPTER 87 OF THE GENERAL STATUTES OF NORTH CAROLINA FOR LICENSING REQUIREMENTS WITHIN 60 CALENDAR DAYS OF BID OPENING.

BIDS WILL BE RECEIVED AS SHOWN BELOW:

THIS IS A ROADWAY & STRUCTURE PROPOSAL

5% BID BOND OR BID DEPOSIT REQUIRED

**PROPOSAL FOR THE CONSTRUCTION OF
CONTRACT No. C204130 IN MACON COUNTY, NORTH CAROLINA**

Date _____ 20 _____

**DEPARTMENT OF TRANSPORTATION,
RALEIGH, NORTH CAROLINA**

The Bidder has carefully examined the location of the proposed work to be known as Contract No. **C204130** has carefully examined the plans and specifications, which are acknowledged to be part of the proposal, the special provisions, the proposal, the form of contract, and the forms of contract payment bond and contract performance bond; and thoroughly understands the stipulations, requirements and provisions. The undersigned bidder agrees to bound upon his execution of the bid and subsequent award to him by the Board of Transportation in accordance with this proposal to provide the necessary contract payment bond and contract performance bond within fourteen days after the written notice of award is received by him. The undersigned Bidder further agrees to provide all necessary machinery, tools, labor, and other means of construction; and to do all the work and to furnish all materials, except as otherwise noted, necessary to perform and complete the said contract in accordance with *the 2018 Standard Specifications for Roads and Structures* by the dates(s) specified in the Project Special Provisions and in accordance with the requirements of the Engineer, and at the unit or lump sum prices, as the case may be, for the various items given on the sheets contained herein.

The Bidder shall provide and furnish all the materials, machinery, implements, appliances and tools, and perform the work and required labor to construct and complete State Highway Contract No. **C204130** in **Macon County**, for the unit or lump sum prices, as the case may be, bid by the Bidder in his bid and according to the proposal, plans, and specifications prepared by said Department, which proposal, plans, and specifications show the details covering this project, and hereby become a part of this contract.

The published volume entitled *North Carolina Department of Transportation, Raleigh, Standard Specifications for Roads and Structures, January 2018* with all amendments and supplements thereto, is by reference incorporated into and made a part of this contract; that, except as herein modified, all the construction and work included in this contract is to be done in accordance with the specifications contained in said volume, and amendments and supplements thereto, under the direction of the Engineer.

If the proposal is accepted and the award is made, the contract is valid only when signed either by the Contract Officer or such other person as may be designated by the Secretary to sign for the Department of Transportation. The conditions and provisions herein cannot be changed except over the signature of the said Contract Officer.

The quantities shown in the itemized proposal for the project are considered to be approximate only and are given as the basis for comparison of bids. The Department of Transportation may increase or decrease the quantity of any item or portion of the work as may be deemed necessary or expedient.

An increase or decrease in the quantity of an item will not be regarded as sufficient ground for an increase or decrease in the unit prices, nor in the time allowed for the completion of the work, except as provided for the contract.

Accompanying this bid is a bid bond secured by a corporate surety, or certified check payable to the order of the Department of Transportation, for five percent of the total bid price, which deposit is to be forfeited as liquidated damages in case this bid is accepted and the Bidder shall fail to provide the required payment and performance bonds with the Department of Transportation, under the condition of this proposal, within 14 calendar days after the written notice of award is received by him, as provided in the *Standard Specifications*; otherwise said deposit will be returned to the Bidder.



State Contract Officer

DocuSigned by:
Ronald E. Davenport, Jr.
F81B6038A47A442...
11/14/2018

TABLE OF CONTENTS

COVER SHEET
PROPOSAL SHEET

PROJECT SPECIAL PROVISIONS

CONTRACT TIME AND LIQUIDATED DAMAGES: G-1
INTERMEDIATE CONTRACT TIME NUMBER 1 AND LIQUIDATED DAMAGES: G-1
INTERMEDIATE CONTRACT TIME NUMBER 2 AND LIQUIDATED DAMAGES: G-2
INTERMEDIATE CONTRACT TIME NUMBER 3 AND LIQUIDATED DAMAGES: G-3
INTERMEDIATE CONTRACT TIME NUMBER 4 AND LIQUIDATED DAMAGES: G-3
PERMANENT VEGETATION ESTABLISHMENT:..... G-4
CONSTRUCTION MORATORIUM 1:..... G-4
CONSTRUCTION MORATORIUM 2:..... G-4
DELAY IN RIGHT OF ENTRY: G-5
MAJOR CONTRACT ITEMS: G-5
SPECIALTY ITEMS:..... G-5
SPECIAL REQUIREMENTS FOR WORK IN NATIONAL FOREST: G-6
FUEL PRICE ADJUSTMENT:..... G-8
SCHEDULE OF ESTIMATED COMPLETION PROGRESS:..... G-9
MINORITY BUSINESS ENTERPRISE AND WOMEN BUSINESS ENTERPRISE: G-9
CONTRACTOR'S LICENSE REQUIREMENTS: G-24
SUBSURFACE INFORMATION: G-24
MAINTENANCE OF THE PROJECT: G-24
COOPERATION BETWEEN CONTRACTORS:..... G-25
TWELVE MONTH GUARANTEE:..... G-25
OUTSOURCING OUTSIDE THE USA:..... G-26
EROSION AND SEDIMENT CONTROL/STORMWATER CERTIFICATION: G-26
PROCEDURE FOR MONITORING BORROW PIT DISCHARGE:..... G-31

ROADWAY..... R-1

STANDARD SPECIAL PROVISIONS

AVAILABILITY FUNDS – TERMINATION OF CONTRACTS SSP-1
NCDOT GENERAL SEED SPECIFICATION FOR SEED QUALITY SSP-2
ERRATA..... SSP-5
PLANT AND PEST QUARANTINES SSP-6
MINIMUM WAGES SSP-7
TITLE VI AND NONDISCRIMINATION: SSP-8
ON-THE-JOB TRAINING SSP-16

UNIT PROJECT SPECIAL PROVISIONS

GEOTECHNICAL.....GT-1.1
SIGNINGSN-1
PAVEMENT MARKINGS.....PM-1
UTILITY CONSTRUCTIONUC-1

UTILITY BY OTHERSUBO-1
EROSION CONTROL EC-1
TRAFFIC SIGNALS TS-1
STRUCTURE / CULVERTS..... ST-1

PERMITS P-1

PROPOSAL ITEM SHEET

ITEM SHEET(S) (TAN SHEETS)

PROJECT SPECIAL PROVISIONS**GENERAL****CONTRACT TIME AND LIQUIDATED DAMAGES:**

(8-15-00) (Rev. 12-18-07)

108

SP1 G07 A

The date of availability for this contract is **January 2, 2019**, except that work in jurisdictional waters and wetlands shall not begin until a meeting between the DOT, Regulatory Agencies, and the Contractor is held as stipulated in the permits contained elsewhere in this proposal. This delay in availability has been considered in determining the contract time for this project.

The completion date for this contract is **April 30, 2021**.

Except where otherwise provided by the contract, observation periods required by the contract will not be a part of the work to be completed by the completion date and/or intermediate contract times stated in the contract. The acceptable completion of the observation periods that extend beyond the final completion date shall be a part of the work covered by the performance and payment bonds.

The liquidated damages for this contract are **Two Hundred Dollars (\$ 200.00)** per calendar day. These liquidated damages will not be cumulative with any liquidated damages which may become chargeable under Intermediate Contract Time Number 1.

INTERMEDIATE CONTRACT TIME NUMBER 1 AND LIQUIDATED DAMAGES:

(7-1-95) (Rev. 2-21-12)

108

SP1 G13 A

Except for that work required under the Project Special Provisions entitled *Planting, Reforestation* and/or *Permanent Vegetation Establishment*, included elsewhere in this proposal, the Contractor will be required to complete all work included in this contract and shall place and maintain traffic on same.

The date of availability for this intermediate contract time is **January 2, 2019**.

The completion date for this intermediate contract time is **November 1, 2020**.

The liquidated damages for this intermediate contract time are **Two Thousand Dollars (\$ 2,000.00)** per calendar day.

Upon apparent completion of all the work required to be completed by this intermediate date, a final inspection will be held in accordance with Article 105-17 and upon acceptance, the Department will assume responsibility for the maintenance of all work except *Planting, Reforestation* and/or *Permanent Vegetation Establishment*. The Contractor will be responsible for and shall make corrections of all damages to the completed roadway caused by his planting operations, whether occurring prior to or after placing traffic through the project.

INTERMEDIATE CONTRACT TIME NUMBER 2 AND LIQUIDATED DAMAGES:(2-20-07)
A

108

SP1 G14

The Contractor shall complete the required work of installing, maintaining, and removing the traffic control devices for lane closures and restoring traffic to the existing traffic pattern. The Contractor shall not close or narrow a lane of traffic on **Any Road** during the following time restrictions:

DAY AND TIME RESTRICTIONS

**Monday thru Sunday (Everyday)
6:00 AM to 7:00 PM**

In addition, the Contractor shall not close or narrow a lane of traffic on **Any Road**, detain and/or alter the traffic flow on or during holidays, holiday weekends, special events, or any other time when traffic is unusually heavy, including the following schedules:

HOLIDAY AND HOLIDAY WEEKEND LANE CLOSURE RESTRICTIONS

1. For any **unexpected occurrence** that creates unusually high traffic volumes, as directed by the Engineer.
2. For **New Year's Day**, between the hours of **6:00 AM** December 31st and **7:00 PM** January 2nd. If New Year's Day is on a Friday, Saturday, Sunday or Monday, then until **7:00 PM** the following Tuesday.
3. For **Easter**, between the hours of **6:00 AM** Thursday and **7:00 PM** Monday.
4. For **Memorial Day**, between the hours of **6:00 AM** Friday and **7:00 PM** Tuesday.
5. For **Independence Day**, between the hours of **6:00 AM** the day before Independence Day and **7:00 PM** the day after Independence Day.

If **Independence Day** is on a Friday, Saturday, Sunday or Monday, then between the hours of **6:00 AM** the Thursday before Independence Day and **7:00 PM** the Tuesday after Independence Day.
6. For **Labor Day**, between the hours of **6:00 AM** Friday and **7:00 PM** Tuesday.
7. For **Thanksgiving**, between the hours of **6:00 AM** Tuesday and **7:00 PM** Monday.
8. For **Christmas**, between the hours of **6:00 AM** the Friday before the week of Christmas Day and **7:00 PM** the following Tuesday after the week of Christmas Day.
9. For **any event at the Smoky Mountain Center for the Performing Arts** that creates unusually high traffic volumes, as directed by the Engineer.
10. For **any event at the Macon County Fairgrounds** that creates unusually high traffic volumes, as directed by the Engineer.

Holidays and holiday weekends shall include New Year's, Easter, Memorial Day, Independence Day, Labor Day, Thanksgiving, and Christmas. The Contractor shall schedule his work so that lane closures will not be required during these periods, unless otherwise directed by the Engineer.

The time of availability for this intermediate contract work shall be the time the Contractor begins to install all traffic control devices for lane closures according to the time restrictions listed herein.

The completion time for this intermediate contract work shall be the time the Contractor is required to complete the removal of all traffic control devices for lane closures according to the time restrictions stated above and place traffic in the existing traffic pattern.

The restrictions provided in this Intermediate Contract Time do not apply to SR-1152 (Belden Circle) during the work required of Step #1 thru Step #4, as described on Sheet TMP-1B of 17BP.14.R.154.

The liquidated damages are **Five Hundred Dollars (\$ 500.00)** per fifteen (15) minute time period.

INTERMEDIATE CONTRACT TIME NUMBER 3 AND LIQUIDATED DAMAGES:

(2-20-07) (Rev. 6-18-13)

108

SP1 G14

H

The Contractor shall complete the work required of **Phase I Step #2B** as shown on **Sheet TMP-3** and shall place and maintain traffic on same.

The date of availability for this intermediate contract time is either **June 1, 2019** or **August 1, 2019**, as elected by the Contractor.

The completion date for this intermediate contract time will be the date which is **thirty (30) consecutive calendar days** after and including the date the Contractor elects to begin this work.

The liquidated damages are **Five Hundred Dollars (\$ 500.00)** per calendar day.

INTERMEDIATE CONTRACT TIME NUMBER 4 AND LIQUIDATED DAMAGES:

(6-18-13)

108

SP1 G14 L

The Contractor shall complete the work required of **17BP.14.R.154** as shown on **Sheet TMP-1B (17BP.14.R.154)** and shall place and maintain traffic on same.

The date of availability for this intermediate contract time is **January 2, 2019**.

The completion date for this intermediate contract time is **October 1, 2019**.

The liquidated damages are **Five Hundred Dollars (\$ 500.00)** per calendar day.

PERMANENT VEGETATION ESTABLISHMENT:

(2-16-12) (Rev. 10-15-13)

104

SP1 G16

Establish a permanent stand of the vegetation mixture shown in the contract. During the period between initial vegetation planting and final project acceptance, perform all work necessary to establish permanent vegetation on all erodible areas within the project limits, as well as, in borrow and waste pits. This work shall include erosion control device maintenance and installation, repair seeding and mulching, supplemental seeding and mulching, mowing, and fertilizer topdressing, as directed. All work shall be performed in accordance with the applicable section of the *2018 Standard Specifications*. All work required for initial vegetation planting shall be performed as a part of the work necessary for the completion and acceptance of the Intermediate Contract Time (ICT). Between the time of ICT and Final Project acceptance, or otherwise referred to as the vegetation establishment period, the Department will be responsible for preparing the required National Pollutant Discharge Elimination System (NPDES) inspection records.

Once the Engineer has determined that the permanent vegetation establishment requirement has been achieved at an 80% vegetation density (the amount of established vegetation per given area to stabilize the soil) and no erodible areas exist within the project limits, the Contractor will be notified to remove the remaining erosion control devices that are no longer needed. The Contractor will be responsible for, and shall correct any areas disturbed by operations performed in permanent vegetation establishment and the removal of temporary erosion control measures, whether occurring prior to or after placing traffic on the project.

Payment for *Response for Erosion Control, Seeding and Mulching, Repair Seeding, Supplemental Seeding, Mowing, Fertilizer Topdressing, Silt Excavation, and Stone for Erosion Control* will be made at contract unit prices for the affected items. Work required that is not represented by contract line items will be paid in accordance with Articles 104-7 or 104-3 of the *2018 Standard Specifications*. No additional compensation will be made for maintenance and removal of temporary erosion control items.

CONSTRUCTION MORATORIUM 1:

(7-15-14)

SP1 G18A

No in-water work or land disturbance within the 25 feet wide buffer zone will be allowed from October 15 through April 15 of any year.

CONSTRUCTION MORATORIUM 2:

(1-19-16)

SP1 G18C

No tree cutting will be allowed from **April 15** through **October 15** of any year.

DELAY IN RIGHT OF ENTRY:

(7-1-95)

108

SP1 G22 B

The Contractor will not be allowed right of entry to the following parcels prior to the listed dates unless otherwise permitted by the Engineer.

<u>Parcel No.</u>	<u>Property Owner</u>	<u>Date</u>
002	JAMES A. VANDERWOUDE	11-1-2018
003	B & B CONCRETE PRODUCTS INC.	11-1-2018
004	VIOLET KLATT REVOCABLE TRUST	11-1-2018
006	Danny Charles Bates	11-1-2018
006A	Nelson W. Bates (for Archeological Data recovery by NCDOT)	UNKNOWN
7	Becky N. McIntosh (for Archeological Data recovery by NCDOT)	UNKNOWN

MAJOR CONTRACT ITEMS:

(2-19-02)

104

SP1 G28

The following listed items are the major contract items for this contract (see Article 104-5 of the *2018 Standard Specifications*):

Line #	Description
47 —	Asphalt Concrete Base Course, Type B25.0 C
49 —	Asphalt Concrete Surface Course, Type S9.5 C
186 —	4' Diameter Utility Manhole

SPECIALTY ITEMS:

(7-1-95)(Rev. 1-17-12)

108-6

SP1 G37

Items listed below will be the specialty items for this contract (see Article 108-6 of the *2018 Standard Specifications*).

Line #	Description
90 thru 101	Guardrail
102 thru 108	Fencing
113 thru 134	Signing
145 thru 155, 164	Long-Life Pavement Markings
156	Removable Tape
165 thru 166	Permanent Pavement Markers
168 thru 198	Utility Construction
199 thru 226, 229 thru 230	Erosion Control
227 thru 228	Reforestation
231 thru 263	Signals/ITS System

SPECIAL REQUIREMENTS FOR WORK IN NATIONAL FOREST:

(7-1-95)

107-13

SP1 G40

In addition to other requirements in this proposal with respect to clearing, erosion control, protection of environment, etc., comply with the following requirements:

- (A) Comply with the portions of these Special Requirements, entitled "Fire Plan," "Clearing Plan," and "Landscape and Erosion Control Plan." Note the fact that merchantable timber within Forest Service Property will become the property of the Contractor.
- (B) Comply with the following recommendations of the State Fish and Game Department and Forest Service for wildlife and fish management:
 - (1) Take all necessary precautions to avoid damage to fish habitat and exercise every reasonable precaution to prevent muddying or silting live streams.
 - (2) Do not deposit material removed from the roadway or channel changes in live streams or into the streams or stream channel where it would be washed away by high stream flows.
 - (3) Do not haul materials, including logs, brush, and debris, by fording live streams. Instead, provide temporary bridges or other structures for this purpose.
- (C) Dispose of waste material resulting from slides during construction and surplus material at locations approved by the Forest Supervisor. Submit a plan showing the proposed method of disposal at the time approval is requested.
- (D) Treat sections of existing road to be abandoned as a result of the proposed new construction, as designated by the Forest Supervisor, to restore them to their natural state. The necessary treatment will be determined during a joint review between the Forest Service and the State and may include ripping of roadbed, removal of drainage structure, and opening drainage channels. Plans and specifications as mutually deemed appropriate to accomplish the objective will become a part of this stipulation.
- (E) Permanently monument the right of way prior to completion of construction in accordance with State requirements for such right of way, but in any event the minimum requirements will be to place permanent monuments at the intersection of right of way with all property lines, section lines, and at intervals of not more than 1,000 feet along the right-of-way limits.
- (F) Re-establish or restore public land monuments disturbed or destroyed by construction, reconstruction, or maintenance according to instructions of the Bureau of Land Management, Department of the Interior. Do not damage, destroy, or obliterate other land monuments and property corners or witness markers without the prior permission of the Regional Forester. Relocate or re-establish these land monuments, property corners, and witness markers in accordance with standards satisfactory to the Regional Forester.

Fire Protection Plan

During the period of construction, perform both independently and in cooperation with the Forest Service everything that is reasonable and practical to prevent and suppress forest fires on the easement area and in its immediate vicinity. Include provisions in all subcontracts for the construction of the road requiring subcontractors and their respective employees to do likewise. The contractors and subcontractors, shall conform to, but not be limited to, the following Fire Plan:

- (A) Take immediate independent or cooperative action to control and extinguish any fire, regardless of cause, within the easement area and its vicinity.
- (B) Maintain at readily available sites one or more boxes of firefighting tools to be furnished by the Forest Service for forest fire fighting purposes only.
- (C) Perform debris burning only in the center of the right of way, and only after a strip 20 feet wide around each pile is cleared to mineral soil.
- (D) Keep fires compact by throwing in the larger material as it burns. If piles are too close together or burn hot, light every second or third pile; allow these to cool down before firing the others. On slopes start burning at the top and work down. Confine fires to piles at all times.
- (E) Do not leave fires unattended.
- (F) Discontinue burning upon notification by the District Forest Ranger or his representative that fire danger is such that there is abnormal risk.
- (G) Whenever a fire escapes, notify the District Ranger immediately even if the fire is suppressed without Forest Service assistance.
- (H) The contractor or subcontractor responsible will bear the costs, including Forest Service direct costs and value of resources damages, incurred by the Forest Service in controlling and extinguishing any fire on or threatening National Forest lands which they or their employees caused with or without negligence in connection with construction operations.
- (I) Contact the District Ranger 24 hours in advance of burning.

Clearing Plan

Conform to the following clearing plan:

- (A) Dispose of unmerchantable materials including tops, branches, etc., by piling and burning as directed by the Forest Service or used in brush barriers. Alternate methods of disposal, including any of the following methods or combinations of methods (lop and scatter, chip, remove, pile only), shall be approved in advance by the Forest Service.

- (B) The maximum clearing and grubbing limits are to be as shown on the plans except that cutting of hazard trees outside these limits may be done with approval. Confine construction machinery within the clearing limits.

Landscape and Erosion Control Plan

The erosion control plan will be designed and implemented to prevent visible sediment, as defined by NC DEQ regulations, from reaching any defined stream channel.

Conform to, but not be limited to, the following Landscape and Erosion Control Plan.

- (A) Prevent visible sediment from entering any stream channel. If an erosion control practice must be sited in a channel, it shall stop further down-channel transport of visible sediment.
- (B) Bear responsibility for the prevention and control of soil erosion and gully on the right of way and lands adjacent thereto resulting from the construction or maintenance of the road. Revegetate with grass (not Love Grass) or herbaceous plants all ground where the soil has been exposed. Accomplish revegetation within 20 working days following final grading.
- (C) Round the ends of cut sections and the tops of back slopes.
- (D) Vegetate all front and back slopes by liming, fertilizing, mulching and seeding; including any waste area. Mulch critical areas if they are to be exposed greater than 5 working days of probable inclement weather during seasons when seeding is impracticable. Critical areas include all bare soils within 100 feet (slope distance) of perennial and intermittent streams. Mulch these as soon as practical and after final seeding.
- (E) Maintain all erosion control practices in a timely manner to prevent visible sediment from entering any stream channel, until such time that the final revegetation stabilizes the site and prevents erosion and off-site movement of sediment.

FUEL PRICE ADJUSTMENT:

(11-15-05) (Rev. 2-18-14)

109-8

SP1 G43

Revise the *2018 Standard Specifications* as follows:

Page 1-87, Article 109-8, Fuel Price Adjustments, add the following:

The base index price for DIESEL #2 FUEL is \$ **2.3501** per gallon. Where any of the following are included as pay items in the contract, they will be eligible for fuel price adjustment.

The pay items and the fuel factor used in calculating adjustments to be made will be as follows:

Description	Units	Fuel Usage Factor Diesel
Unclassified Excavation	Gal/CY	0.29
Borrow Excavation	Gal/CY	0.29
Class IV Subgrade Stabilization	Gal/Ton	0.55

Aggregate Base Course	Gal/Ton	0.55
Sub-Ballast	Gal/Ton	0.55
Asphalt Concrete Base Course, Type ____	Gal/Ton	2.90
Asphalt Concrete Intermediate Course, Type ____	Gal/Ton	2.90
Asphalt Concrete Surface Course, Type ____	Gal/Ton	2.90
Open-Graded Asphalt Friction Course	Gal/Ton	2.90
Permeable Asphalt Drainage Course, Type ____	Gal/Ton	2.90
Sand Asphalt Surface Course, Type ____	Gal/Ton	2.90
Aggregate for Cement Treated Base Course	Gal/Ton	0.55
Portland Cement for Cement Treated Base Course	Gal/Ton	0.55
__" Portland Cement Concrete Pavement	Gal/SY	0.245
Concrete Shoulders Adjacent to __" Pavement	Gal/SY	0.245

SCHEDULE OF ESTIMATED COMPLETION PROGRESS:

(7-15-08) (Rev. 6-19-18)

108-2

SP1 G58

The Contractor's attention is directed to the Standard Special Provision entitled *Availability of Funds Termination of Contracts* included elsewhere in this proposal. The Department of Transportation's schedule of estimated completion progress for this project as required by that Standard Special Provision is as follows:

	<u>Fiscal Year</u>	<u>Progress (% of Dollar Value)</u>
2019	(7/01/18 - 6/30/19)	38% of Total Amount Bid
2020	(7/01/19 - 6/30/20)	53% of Total Amount Bid
2021	(7/01/20 - 6/30/21)	9% of Total Amount Bid

The Contractor shall also furnish his own progress schedule in accordance with Article 108-2 of the *2018 Standard Specifications*. Any acceleration of the progress as shown by the Contractor's progress schedule over the progress as shown above shall be subject to the approval of the Engineer.

MINORITY BUSINESS ENTERPRISE AND WOMEN BUSINESS ENTERPRISE:

(10-16-07)(Rev. 5-15-18)

102-15(J)

SP1 G66

Description

The purpose of this Special Provision is to carry out the North Carolina Department of Transportation's policy of ensuring nondiscrimination in the award and administration of contracts financed in whole or in part with State funds.

Definitions

Additional MBE/WBE Subcontractors - Any MBE/WBE submitted at the time of bid that will not be used to meet the Combined MBE /WBE Goal. No submittal of a Letter of Intent is required.

Combined MBE/WBE Goal: A portion of the total contract, expressed as a percentage that is to be performed by committed MBE/WBE subcontractors.

Committed MBE/WBE Subcontractor - Any MBE/WBE submitted at the time of bid that is being used to meet the Combined MBE /WBE goal by submission of a Letter of Intent. Or any MBE or WBE used as a replacement for a previously committed MBE or WBE firm.

Contract Goal Requirement - The approved participation at time of award, but not greater than the advertised Combined MBE/WBE contract goal.

Goal Confirmation Letter - Written documentation from the Department to the bidder confirming the Contractor's approved, committed participation along with a listing of the committed MBE and WBE firms.

Manufacturer - A firm that operates or maintains a factory or establishment that produces on the premises, the materials or supplies obtained by the Contractor.

MBE Participation (Anticipated) - A portion of the total contract, expressed as a percentage that is anticipated to be performed by committed MBE subcontractor(s).

Minority Business Enterprise (MBE) - A firm certified as a Disadvantaged Minority-Owned Business Enterprise through the North Carolina Unified Certification Program.

Regular Dealer - A firm that owns, operates, or maintains a store, warehouse, or other establishment in which the materials or supplies required for the performance of the contract are bought, kept in stock, and regularly sold to the public in the usual course of business. A regular dealer engages in, as its principal business and in its own name, the purchase and sale or lease of the products in question. A regular dealer in such bulk items as steel, cement, gravel, stone, and petroleum products need not keep such products in stock, if it owns and operates distribution equipment for the products. Brokers and packagers are not regarded as manufacturers or regular dealers within the meaning of this section.

North Carolina Unified Certification Program (NCUCP) - A program that provides comprehensive services and information to applicants for MBE/WBE certification. The MBE/WBE program follows the same regulations as the federal Disadvantaged Business Enterprise (DBE) program in accordance with 49 CFR Part 26.

United States Department of Transportation (USDOT) - Federal agency responsible for issuing regulations (49 CFR Part 26) and official guidance for the DBE program.

WBE Participation (Anticipated) - A portion of the total contract, expressed as a percentage, that is anticipated to be performed by committed WBE subcontractor(s).

Women Business Enterprise (WBE) - A firm certified as a Disadvantaged Women-Owned Business Enterprise through the North Carolina Unified Certification Program.

Forms and Websites Referenced in this Provision

Payment Tracking System - On-line system in which the Contractor enters the payments made to MBE and WBE subcontractors who have performed work on the project.
<https://apps.dot.state.nc.us/Vendor/PaymentTracking/>

DBE-IS Subcontractor Payment Information - Form for reporting the payments made to all MBE/WBE firms working on the project. This form is for paper bid projects only.
<https://connect.ncdot.gov/business/Turnpike/Documents/Form%20DBE-IS%20Subcontractor%20Payment%20Information.pdf>

RF-1 MBE/WBE Replacement Request Form - Form for replacing a committed MBE or WBE.
<http://connect.ncdot.gov/projects/construction/Construction%20Forms/DBE%20MBE%20WBE%20Replacement%20Request%20Form.pdf>

SAF Subcontract Approval Form - Form required for approval to sublet the contract.
<http://connect.ncdot.gov/projects/construction/Construction%20Forms/Subcontract%20Approval%20Form%20Rev.%202012.zip>

JC-1 Joint Check Notification Form - Form and procedures for joint check notification. The form acts as a written joint check agreement among the parties providing full and prompt disclosure of the expected use of joint checks.
<http://connect.ncdot.gov/projects/construction/Construction%20Forms/Joint%20Check%20Notification%20Form.pdf>

Letter of Intent - Form signed by the Contractor and the MBE/WBE subcontractor, manufacturer or regular dealer that affirms that a portion of said contract is going to be performed by the signed MBE/WBE for the estimated amount (based on quantities and unit prices) listed at the time of bid.
<http://connect.ncdot.gov/letting/LetCentral/Letter%20of%20Intent%20to%20Perform%20as%20a%20Subcontractor.pdf>

Listing of MBE and WBE Subcontractors Form - Form for entering MBE/WBE subcontractors on a project that will meet the Combined MBE/WBE goal. This form is for paper bids only.
[http://connect.ncdot.gov/municipalities/Bid%20Proposals%20for%20LGA%20Content/09%20MBE-WBE%20Subcontractors%20\(State\).docx](http://connect.ncdot.gov/municipalities/Bid%20Proposals%20for%20LGA%20Content/09%20MBE-WBE%20Subcontractors%20(State).docx)

Subcontractor Quote Comparison Sheet - Spreadsheet for showing all subcontractor quotes in the work areas where MBEs and WBEs quoted on the project. This sheet is submitted with good faith effort packages.
<http://connect.ncdot.gov/business/SmallBusiness/Documents/DBE%20Subcontractor%20Quote%20Comparison%20Example.xls>

Combined MBE/WBE Goal

The Combined MBE/WBE Goal for this project is **7.0 %**

The Combined Goal was established utilizing the following anticipated participation for Minority Business Enterprises and Women Business Enterprises:

(A) Minority Business Enterprises **3.0 %**

- (1) *If the anticipated MBE participation is more than zero*, the Contractor shall exercise all necessary and reasonable steps to ensure that MBEs participate in at least the percent of the contract as set forth above.

- (2) *If the anticipated MBE participation is zero*, the Contractor shall make an effort to recruit and use MBEs during the performance of the contract. Any MBE participation obtained shall be reported to the Department.
- (B) Women Business Enterprises **4.0 %**
- (1) *If the anticipated WBE participation is more than zero*, the Contractor shall exercise all necessary and reasonable steps to ensure that WBEs participate in at least the percent of the contract as set forth above.
 - (2) *If the anticipated WBE participation is zero*, the Contractor shall make an effort to recruit and use WBEs during the performance of the contract. Any WBE participation obtained shall be reported to the Department.

The Bidder is required to submit only participation to meet the Combined MBE/WBE Goal. The Combined Goal may be met by submitting all MBE participation, all WBE participation, or a combination of MBE and WBE participation.

Directory of Transportation Firms (Directory)

Real-time information is available about firms doing business with the Department and firms that are certified through NCUCP in the Directory of Transportation Firms. Only firms identified in the Directory as MBE and WBE certified shall be used to meet the Combined MBE/WBE Goal. The Directory can be found at the following link.

<https://www.ebs.nc.gov/VendorDirectory/default.html>

The listing of an individual firm in the directory shall not be construed as an endorsement of the firm's capability to perform certain work.

Listing of MBE/WBE Subcontractors

At the time of bid, bidders shall submit all MBE and WBE participation that they anticipate to use during the life of the contract. Only those identified to meet the Combined MBE/WBE Goal will be considered committed, even though the listing shall include both committed MBE/WBE subcontractors and additional MBE/WBE subcontractors. Any additional MBE/WBE subcontractor participation above the goal will follow the banking guidelines found elsewhere in this provision. All other additional MBE/WBE subcontractor participation submitted at the time of bid will be used toward the Department's overall race-neutral goals. Only those firms with current MBE and WBE certification at the time of bid opening will be acceptable for listing in the bidder's submittal of MBE and WBE participation. The Contractor shall indicate the following required information:

- (A) Electronic Bids

Bidders shall submit a listing of MBE and WBE participation in the appropriate section of Expedite, the bidding software of Bid Express®.

- (1) Submit the names and addresses of MBE and WBE firms identified to participate in the contract. If the bidder uses the updated listing of MBE and WBE firms shown in Expedite, the bidder may use the dropdown menu to access the name and address of the firms.
- (2) Submit the contract line numbers of work to be performed by each MBE and WBE firm. When no figures or firms are entered, the bidder will be considered to have no MBE or WBE participation.
- (3) The bidder shall be responsible for ensuring that the MBE and WBE are certified at the time of bid by checking the Directory of Transportation Firms. If the firm is not certified at the time of the bid-letting, that MBE's or WBE's participation will not count towards achieving the Combined MBE/WBE goal.

(B) Paper Bids

- (1) *If the Combined MBE/WBE Goal is more than zero,*
 - (a) Bidders, at the time the bid proposal is submitted, shall submit a listing of MBE/WBE participation, including the names and addresses on *Listing of MBE and WBE Subcontractors* contained elsewhere in the contract documents in order for the bid to be considered responsive. Bidders shall indicate the total dollar value of the MBE and WBE participation for the contract.
 - (b) If bidders have no MBE or WBE participation, they shall indicate this on the *Listing of MBE and WBE Subcontractors* by entering the word "None" or the number "0." This form shall be completed in its entirety. **Blank forms will not be deemed to represent zero participation.** Bids submitted that do not have MBE and WBE participation indicated on the appropriate form will not be read publicly during the opening of bids. The Department will not consider these bids for award and the proposal will be rejected.
 - (c) The bidder shall be responsible for ensuring that the MBE/WBE is certified at the time of bid by checking the Directory of Transportation Firms. If the firm is not certified at the time of the bid-letting, that MBE's or WBE's participation will not count towards achieving the Combined MBE/WBE Goal.
- (2) *If the Combined MBE/WBE Goal is zero,* entries on the *Listing of MBE and WBE Subcontractors* are not required for the zero goal, however any MBE or WBE participation that is achieved during the project shall be reported in accordance with requirements contained elsewhere in the special provision.

MBE or WBE Prime Contractor

When a certified MBE or WBE firm bids on a contract that contains a Combined MBE/WBE goal, the firm is responsible for meeting the goal or making good faith efforts to meet the goal, just like any other bidder. In most cases, a MBE or WBE bidder on a contract will meet the Combined MBE/WBE Goal by virtue of the work it performs on the contract with its own forces. However, all the work that is performed by the MBE or WBE bidder and any other similarly certified subcontractors will count toward the goal. The MBE or WBE bidder shall list itself along with any MBE or WBE subcontractors, if any, in order to receive credit toward the goal.

MBE/WBE prime contractors shall also follow Sections A and B listed under *Listing of MBE/WBE Subcontractor* just as a non-MBE/WBE bidder would.

Written Documentation – Letter of Intent

The bidder shall submit written documentation for each MBE/WBE that will be used to meet the Combined MBE/WBE Goal of the contract, indicating the bidder's commitment to use the MBE/WBE in the contract. This documentation shall be submitted on the Department's form titled *Letter of Intent*.

The documentation shall be received in the office of the State Contractor Utilization Engineer or at DBE@ncdot.gov no later than 10:00 a.m. of the sixth calendar day following opening of bids, unless the sixth day falls on an official state holiday. In that situation, it is due in the office of the State Contractor Utilization Engineer no later than 10:00 a.m. on the next official state business day.

If the bidder fails to submit the Letter of Intent from each committed MBE and WBE to be used toward the Combined MBE/WBE Goal, or if the form is incomplete (i.e. both signatures are not present), the MBE/WBE participation will not count toward meeting the Combined MBE/WBE Goal. If the lack of this participation drops the commitment below the Combined MBE/WBE Goal, the Contractor shall submit evidence of good faith efforts for the goal, completed in its entirety, to the State Contractor Utilization Engineer or DBE@ncdot.gov no later than 10:00 a.m. on the eighth calendar day following opening of bids, unless the eighth day falls on an official state holiday. In that situation, it is due in the office of the State Contractor Utilization Engineer no later than 10:00 a.m. on the next official state business day.

Banking MBE/WBE Credit

If the bid of the lowest responsive bidder exceeds \$500,000 and if the committed MBE/WBE participation submitted exceeds the algebraic sum of the Combined MBE/WBE Goal by \$1,000 or more, the excess will be placed on deposit by the Department for future use by the bidder. Separate accounts will be maintained for MBE and WBE participation and these may accumulate for a period not to exceed 24 months.

When the apparent lowest responsive bidder fails to submit sufficient participation by MBE and WBE firms to meet the advertised goal, as part of the good faith effort, the Department will consider allowing the bidder to withdraw funds to meet the Combined MBE/WBE Goal as long as there are adequate funds available from the bidder's MBE and WBE bank accounts.

Submission of Good Faith Effort

If the bidder fails to meet or exceed the Combined MBE/WBE Goal, the apparent lowest responsive bidder shall submit to the Department documentation of adequate good faith efforts made to reach that specific goal.

A hard copy and an electronic copy of this information shall be received in the office of the State Contractor Utilization Engineer or at DBE@ncdot.gov no later than 10:00 a.m. on the sixth calendar day following opening of bids unless the sixth day falls on an official state holiday. In that situation, it would be due in the office of the State Contractor Utilization Engineer no later than 10:00 a.m. on the next official state business day. If the contractor cannot send the information electronically, then one complete set and 5 copies of this information shall be received under the same time constraints above.

Note: Where the information submitted includes repetitious solicitation letters, it will be acceptable to submit a representative letter along with a distribution list of the firms that were solicited. Documentation of MBE/WBE quotations shall be a part of the good faith effort submittal. This documentation may include written subcontractor quotations, telephone log notations of verbal quotations, or other types of quotation documentation.

Consideration of Good Faith Effort for Projects with a Combined MBE/WBE Goal More Than Zero

Adequate good faith efforts mean that the bidder took all necessary and reasonable steps to achieve the goal which, by their scope, intensity, and appropriateness, could reasonably be expected to obtain sufficient MBE/WBE participation. Adequate good faith efforts also mean that the bidder actively and aggressively sought MBE/WBE participation. Mere *pro forma* efforts are not considered good faith efforts.

The Department will consider the quality, quantity, and intensity of the different kinds of efforts a bidder has made. Listed below are examples of the types of actions a bidder will take in making a good faith effort to meet the goals and are not intended to be exclusive or exhaustive, nor is it intended to be a mandatory checklist.

- (A) Soliciting through all reasonable and available means (e.g. attendance at pre-bid meetings, advertising, written notices, use of verifiable electronic means through the use of the NCDOT Directory of Transportation Firms) the interest of all certified MBEs/WBEs that are also prequalified subcontractors. The bidder must solicit this interest within at least 10 days prior to bid opening to allow the MBEs/WBEs to respond to the solicitation. Solicitation shall provide the opportunity to MBEs/WBEs within the Division and surrounding Divisions where the project is located. The bidder must determine with certainty if the MBEs/WBEs are interested by taking appropriate steps to follow up initial solicitations.

- (B) Selecting portions of the work to be performed by MBEs/WBEs in order to increase the likelihood that the Combined MBE/WBE Goal will be achieved.
- (1) Where appropriate, break out contract work items into economically feasible units to facilitate MBE/WBE participation, even when the prime contractor might otherwise prefer to perform these work items with its own forces.
 - (2) Negotiate with subcontractors to assume part of the responsibility to meet the advertised goal when the work to be sublet includes potential for MBE/WBE participation (2nd and 3rd tier subcontractors).
- (C) Providing interested certified MBEs/WBEs that are also prequalified subcontractors with adequate information about the plans, specifications, and requirements of the contract in a timely manner to assist them in responding to a solicitation.
- (D) (1) Negotiating in good faith with interested MBEs/WBEs. It is the bidder's responsibility to make a portion of the work available to MBE/WBE subcontractors and suppliers and to select those portions of the work or material needs consistent with the available MBE/WBE subcontractors and suppliers, so as to facilitate MBE/WBE participation. Evidence of such negotiation includes the names, addresses, and telephone numbers of MBEs/WBEs that were considered; a description of the information provided regarding the plans and specifications for the work selected for subcontracting; and evidence as to why additional agreements could not be reached for MBEs/WBEs to perform the work.
- (2) A bidder using good business judgment would consider a number of factors in negotiating with subcontractors, including MBE/WBE subcontractors, and would take a firm's price and capabilities as well as the advertised goal into consideration. However, the fact that there may be some additional costs involved in finding and using MBEs/WBEs is not in itself sufficient reason for a bidder's failure to meet the contract goal, as long as such costs are reasonable. Also, the ability or desire of a prime contractor to perform the work of a contract with its own organization does not relieve the bidder of the responsibility to make good faith efforts. Bidding contractors are not, however, required to accept higher quotes from MBEs/WBEs if the price difference is excessive or unreasonable.
- (E) Not rejecting MBEs/WBEs as being unqualified without sound reasons based on a thorough investigation of their capabilities. The bidder's standing within its industry, membership in specific groups, organizations, or associates and political or social affiliations (for example, union vs. non-union employee status) are not legitimate causes for the rejection or non-solicitation of bids in the bidder's efforts to meet the project goal.
- (F) Making efforts to assist interested MBEs/WBEs in obtaining bonding, lines of credit, or insurance as required by the recipient or bidder.
- (G) Making efforts to assist interested MBEs/WBEs in obtaining necessary equipment, supplies, materials, or related assistance or services.

- (H) Effectively using the services of available minority/women community organizations; minority/women contractors' groups; Federal, State, and local minority/women business assistance offices; and other organizations as allowed on a case-by-case basis to provide assistance in the recruitment and placement of MBEs/WBEs. Contact within 7 days from the bid opening the Business Opportunity and Work Force Development Unit at BOWD@ncdot.gov to give notification of the bidder's inability to get MBE or WBE quotes.
- (I) Any other evidence that the bidder submits which shows that the bidder has made reasonable good faith efforts to meet the advertised goal.

In addition, the Department may take into account the following:

- (1) Whether the bidder's documentation reflects a clear and realistic plan for achieving the Combined MBE/WBE Goal.
- (2) The bidders' past performance in meeting the contract goal.
- (3) The performance of other bidders in meeting the advertised goal. For example, when the apparent successful bidder fails to meet the goal, but others meet it, you may reasonably raise the question of whether, with additional reasonable efforts the apparent successful bidder could have met the goal. If the apparent successful bidder fails to meet the advertised goal, but meets or exceeds the average MBE and WBE participation obtained by other bidders, the Department may view this, in conjunction with other factors, as evidence of the apparent successful bidder having made a good faith effort.

If the Department does not award the contract to the apparent lowest responsive bidder, the Department reserves the right to award the contract to the next lowest responsive bidder that can satisfy to the Department that the Combined MBE/WBE Goal can be met or that an adequate good faith effort has been made to meet the advertised goal.

Non-Good Faith Appeal

The State Contractual Services Engineer will notify the contractor verbally and in writing of non-good faith. A contractor may appeal a determination of non-good faith made by the Goal Compliance Committee. If a contractor wishes to appeal the determination made by the Committee, they shall provide written notification to the State Contractual Services Engineer or at DBE@ncdot.gov. The appeal shall be made within 2 business days of notification of the determination of non-good faith.

Counting MBE/WBE Participation Toward Meeting the Combined MBE/WBE Goal

- (A) Participation

The total dollar value of the participation by a committed MBE/WBE will be counted toward the contract goal requirements. The total dollar value of participation by

a committed MBE/WBE will be based upon the value of work actually performed by the MBE/WBE and the actual payments to MBE/WBE firms by the Contractor.

(B) Joint Checks

Prior notification of joint check use shall be required when counting MBE/WBE participation for services or purchases that involves the use of a joint check. Notification shall be through submission of Form JC-1 (*Joint Check Notification Form*) and the use of joint checks shall be in accordance with the Department's Joint Check Procedures.

(C) Subcontracts (Non-Trucking)

A MBE/WBE may enter into subcontracts. Work that a MBE subcontracts to another MBE firm may be counted toward the anticipated MBE participation. The same holds true for work that a WBE subcontracts to another WBE firm. Work that a MBE/WBE subcontracts to a non-MBE/WBE firm does not count toward the contract goal requirement. It should be noted that every effort shall be made by MBE and WBE contractors to subcontract to the same certification (i.e., MBEs to MBEs and WBEs to WBEs), in order to fulfill the MBE or WBE participation breakdown. This, however, may not always be possible due to the limitation of firms in the area. If the MBE or WBE firm shows a good faith effort has been made to reach out to similarly certified firms and there is no interest or availability, and they can get assistance from other certified firms, the Engineer will not hold the prime responsible for meeting the individual MBE or WBE breakdown. If a MBE or WBE contractor or subcontractor subcontracts a significantly greater portion of the work of the contract than would be expected on the basis of standard industry practices, it shall be presumed that the MBE or WBE is not performing a commercially useful function.

(D) Joint Venture

When a MBE or WBE performs as a participant in a joint venture, the Contractor may count toward its contract goal requirement a portion of the total value of participation with the MBE or WBE in the joint venture, that portion of the total dollar value being a distinct clearly defined portion of work that the MBE or WBE performs with its forces.

(E) Suppliers

A contractor may count toward its MBE/ WBE requirement 60 percent of its expenditures for materials and supplies required to complete the contract and obtained from a MBE or WBE regular dealer and 100 percent of such expenditures from a MBE or WBE manufacturer.

(F) Manufacturers and Regular Dealers

A contractor may count toward its MBE/ WBE requirement the following expenditures to MBE/WBE firms that are not manufacturers or regular dealers:

- (1) The fees or commissions charged by a MBE/WBE firm for providing a *bona fide* service, such as professional, technical, consultant, or managerial services, or for providing bonds or insurance specifically required for the performance of a DOT-assisted contract, provided the fees or commissions are determined to be reasonable and not excessive as compared with fees and commissions customarily allowed for similar services.
- (2) With respect to materials or supplies purchased from a MBE/WBE, which is neither a manufacturer nor a regular dealer, count the entire amount of fees or commissions charged for assistance in the procurement of the materials and supplies, or fees or transportation charges for the delivery of materials or supplies required on a job site (but not the cost of the materials and supplies themselves), provided the fees are determined to be reasonable and not excessive as compared with fees customarily allowed for similar services.

Commercially Useful Function

(A) MBE/WBE Utilization

The Contractor may count toward its contract goal requirement only expenditures to MBEs and WBEs that perform a commercially useful function in the work of a contract. A MBE/WBE performs a commercially useful function when it is responsible for execution of the work of the contract and is carrying out its responsibilities by actually performing, managing, and supervising the work involved. To perform a commercially useful function, the MBE/WBE shall also be responsible with respect to materials and supplies used on the contract, for negotiating price, determining quality and quantity, ordering the material and installing (where applicable) and paying for the material itself. To determine whether a MBE/WBE is performing a commercially useful function, the Department will evaluate the amount of work subcontracted, industry practices, whether the amount the firm is to be paid under the contract is commensurate with the work it is actually performing and the MBE/WBE credit claimed for its performance of the work, and any other relevant factors. If it is determined that a MBE or WBE is not performing a Commercially Useful Function, the contractor may present evidence to rebut this presumption to the Department.

(B) MBE/WBE Utilization in Trucking

The following factors will be used to determine if a MBE or WBE trucking firm is performing a commercially useful function:

- (1) The MBE/WBE shall be responsible for the management and supervision of the entire trucking operation for which it is responsible on a particular contract, and

there shall not be a contrived arrangement for the purpose of meeting the Combined MBE/WBE Goal.

- (2) The MBE/WBE shall itself own and operate at least one fully licensed, insured, and operational truck used on the contract.
- (3) The MBE/WBE receives credit for the total value of the transportation services it provides on the contract using trucks it owns, insures, and operates using drivers it employs.
- (4) The MBE may subcontract the work to another MBE firm, including an owner-operator who is certified as a MBE. The same holds true that a WBE may subcontract the work to another WBE firm, including an owner-operator who is certified as a WBE. When this occurs, the MBE or WBE who subcontracts work receives credit for the total value of the transportation services the subcontracted MBE or WBE provides on the contract. It should be noted that every effort shall be made by MBE and WBE contractors to subcontract to the same certification (i.e., MBEs to MBEs and WBEs to WBEs), in order to fulfill the participation breakdown. This, however, may not always be possible due to the limitation of firms in the area. If the MBE or WBE firm shows a good faith effort has been made to reach out to similarly certified transportation service providers and there is no interest or availability, and they can get assistance from other certified providers, the Engineer will not hold the prime responsible for meeting the individual MBE or WBE participation breakdown.
- (5) The MBE/WBE may also subcontract the work to a non-MBE/WBE firm, including from an owner-operator. The MBE/WBE who subcontracts the work to a non-MBE/WBE is entitled to credit for the total value of transportation services provided by the non-MBE/WBE subcontractor not to exceed the value of transportation services provided by MBE/WBE-owned trucks on the contract. Additional participation by non-MBE/WBE subcontractors receives credit only for the fee or commission it receives as a result of the subcontract arrangement. The value of services performed under subcontract agreements between the MBE/WBE and the Contractor will not count towards the MBE/WBE contract requirement.
- (6) A MBE/WBE may lease truck(s) from an established equipment leasing business open to the general public. The lease must indicate that the MBE/WBE has exclusive use of and control over the truck. This requirement does not preclude the leased truck from working for others during the term of the lease with the consent of the MBE/WBE, so long as the lease gives the MBE/WBE absolute priority for use of the leased truck. This type of lease may count toward the MBE/WBE's credit as long as the driver is under the MBE/WBE's payroll.
- (7) Subcontracted/leased trucks shall display clearly on the dashboard the name of the MBE/WBE that they are subcontracted/leased to and their own company name if it is not identified on the truck itself. Magnetic door signs are not permitted.

MBE/WBE Replacement

When a Contractor has relied on a commitment to a MBE or WBE firm (or an approved substitute MBE or WBE firm) to meet all or part of a contract goal requirement, the contractor shall not terminate the MBE/WBE for convenience. This includes, but is not limited to, instances in which the Contractor seeks to perform the work of the terminated subcontractor with another MBE/WBE subcontractor, a non-MBE/WBE subcontractor, or with the Contractor's own forces or those of an affiliate. A MBE/WBE may only be terminated after receiving the Engineer's written approval based upon a finding of good cause for the proposed termination. The prime contractor must give the MBE/WBE firm 5 days to respond to the prime contractor's notice of intent to terminate and advise the prime contractor and the Department of the reasons, if any, why the firm objects to the proposed termination of its subcontract and why the Department should not approve the action.

All requests for replacement of a committed MBE/WBE firm shall be submitted to the Engineer for approval on Form RF-1 (*Replacement Request*). If the Contractor fails to follow this procedure, the Contractor may be disqualified from further bidding for a period of up to 6 months.

The Contractor shall comply with the following for replacement of a committed MBE/WBE:

(A) Performance Related Replacement

When a committed MBE/WBE is terminated for good cause as stated above, an additional MBE/WBE that was submitted at the time of bid may be used to fulfill the MBE/WBE commitment to meet the Combined MBE/WBE Goal. A good faith effort will only be required for removing a committed MBE/WBE if there were no additional MBEs/WBEs submitted at the time of bid to cover the same amount of work as the MBE/WBE that was terminated.

If a replacement MBE/WBE is not found that can perform at least the same amount of work as the terminated MBE/WBE, the Contractor shall submit a good faith effort documenting the steps taken. Such documentation shall include, but not be limited to, the following:

- (1) Copies of written notification to MBEs/WBEs that their interest is solicited in contracting the work defaulted by the previous MBE/WBE or in subcontracting other items of work in the contract.
- (2) Efforts to negotiate with MBEs/WBEs for specific subbids including, at a minimum:
 - (a) The names, addresses, and telephone numbers of MBEs/WBEs who were contacted.
 - (b) A description of the information provided to MBEs/WBEs regarding the plans and specifications for portions of the work to be performed.
- (3) A list of reasons why MBE/WBE quotes were not accepted.
- (4) Efforts made to assist the MBEs/WBEs contacted, if needed, in obtaining bonding or insurance required by the Contractor.

(B) Decertification Replacement

- (1) When a committed MBE/WBE is decertified by the Department after the SAF (*Subcontract Approval Form*) has been received by the Department, the Department will not require the Contractor to solicit replacement MBE/WBE participation equal to the remaining work to be performed by the decertified firm. The participation equal to the remaining work performed by the decertified firm will count toward the contract goal requirement.
- (2) When a committed MBE/WBE is decertified prior to the Department receiving the SAF (*Subcontract Approval Form*) for the named MBE/WBE firm, the Contractor shall take all necessary and reasonable steps to replace the MBE/WBE subcontractor with another similarly certified MBE/WBE subcontractor to perform at least the same amount of work to meet the Combined MBE/WBE Goal requirement. If a MBE/WBE firm is not found to do the same amount of work, a good faith effort must be submitted to NCDOT (see A herein for required documentation).

Changes in the Work

When the Engineer makes changes that result in the reduction or elimination of work to be performed by a committed MBE/WBE, the Contractor will not be required to seek additional participation. When the Engineer makes changes that result in additional work to be performed by a MBE/WBE based upon the Contractor's commitment, the MBE/WBE shall participate in additional work to the same extent as the MBE/WBE participated in the original contract work.

When the Engineer makes changes that result in extra work, which has more than a minimal impact on the contract amount, the Contractor shall seek additional participation by MBEs/WBEs unless otherwise approved by the Engineer.

When the Engineer makes changes that result in an alteration of plans or details of construction, and a portion or all of the work had been expected to be performed by a committed MBE/WBE, the Contractor shall seek participation by MBEs/WBEs unless otherwise approved by the Engineer.

When the Contractor requests changes in the work that result in the reduction or elimination of work that the Contractor committed to be performed by a MBE/WBE, the Contractor shall seek additional participation by MBEs/WBEs equal to the reduced MBE/WBE participation caused by the changes.

Reports and Documentation

A SAF (*Subcontract Approval Form*) shall be submitted for all work which is to be performed by a MBE/WBE subcontractor. The Department reserves the right to require copies of actual subcontract agreements involving MBE/WBE subcontractors.

When using transportation services to meet the contract commitment, the Contractor shall submit a proposed trucking plan in addition to the SAF. The plan shall be submitted prior to beginning construction on the project. The plan shall include the names of all trucking firms proposed for use, their certification type(s), the number of trucks owned by the firm, as well as the individual truck identification numbers, and the line item(s) being performed.

Within 30 calendar days of entering into an agreement with a MBE/WBE for materials, supplies or services, not otherwise documented by the SAF as specified above, the Contractor shall furnish the Engineer a copy of the agreement. The documentation shall also indicate the percentage (60% or 100%) of expenditures claimed for MBE/WBE credit.

Reporting Minority and Women Business Enterprise Participation

The Contractor shall provide the Engineer with an accounting of payments made to all MBE/WBE firms, including material suppliers and contractors at all levels (prime, subcontractor, or second tier subcontractor). This accounting shall be furnished to the Engineer for any given month by the end of the following month. Failure to submit this information accordingly may result in the following action:

- (A) Withholding of money due in the next partial pay estimate; or
- (B) Removal of an approved contractor from the prequalified bidders' list or the removal of other entities from the approved subcontractors list.

While each contractor (prime, subcontractor, 2nd tier subcontractor) is responsible for accurate accounting of payments to MBEs/WBEs, it shall be the prime contractor's responsibility to report all monthly and final payment information in the correct reporting manner.

Failure on the part of the Contractor to submit the required information in the time frame specified may result in the disqualification of that contractor and any affiliate companies from further bidding until the required information is submitted.

Failure on the part of any subcontractor to submit the required information in the time frame specified may result in the disqualification of that contractor and any affiliate companies from being approved for work on future DOT projects until the required information is submitted.

Contractors reporting transportation services provided by non-MBE/WBE lessees shall evaluate the value of services provided during the month of the reporting period only.

At any time, the Engineer can request written verification of subcontractor payments.

The Contractor shall report the accounting of payments through the Department's Payment Tracking System.

Failure to Meet Contract Requirements

Failure to meet contract requirements in accordance with Subarticle 102-15(J) of the *2018 Standard Specifications* may be cause to disqualify the Contractor.

CONTRACTOR'S LICENSE REQUIREMENTS:

(7-1-95)

102-14

SP1 G88

If the successful bidder does not hold the proper license to perform any plumbing, heating, air conditioning, or electrical work in this contract, he will be required to sublet such work to a contractor properly licensed in accordance with *Article 2 of Chapter 87 of the General Statutes* (licensing of heating, plumbing, and air conditioning contractors) and *Article 4 of Chapter 87 of the General Statutes* (licensing of electrical contractors).

SUBSURFACE INFORMATION:

(7-1-95)

450

SP1 G112 D

Subsurface information is available on the roadway and structure portions of this project.

MAINTENANCE OF THE PROJECT:

(11-20-07) (Rev. 1-17-12)

104-10

SP1 G125

Revise the *2018 Standard Specifications* as follows:

Page 1-39, Article 104-10 Maintenance of the Project, line 25, add the following after the first sentence of the first paragraph:

All guardrail/guiderail within the project limits shall be included in this maintenance.

Page 1-39, Article 104-10 Maintenance of the Project, line 30, add the following as the last sentence of the first paragraph:

The Contractor shall perform weekly inspections of guardrail and guiderail and shall report damages to the Engineer on the same day of the weekly inspection. *Where damaged guardrail or guiderail is repaired or replaced as a result of maintaining the project in accordance with this article, such repair or replacement shall be performed within 7 consecutive calendar days of such inspection report.*

Page 1-39, Article 104-10 Maintenance of the Project, lines 42-44, replace the last sentence of the last paragraph with the following:

The Contractor will not be directly compensated for any maintenance operations necessary, except for maintenance of guardrail/guiderail, as this work will be considered incidental to the work covered by the various contract items. The provisions of Article 104-7, Extra Work, and Article 104-8, Compensation and Record Keeping will apply to authorized maintenance of guardrail/guiderail. Performance of weekly inspections of guardrail/guiderail, and the damage reports required as described above, will be considered to be an incidental part of the work being paid for by the various contract items.

COOPERATION BETWEEN CONTRACTORS:

(7-1-95)

105-7

SP1 G133

The Contractor's attention is directed to Article 105-7 of the *2018 Standard Specifications*.

2018CPT.14.12.10561, etc. (C204191) is currently under construction and will not be completed prior to the letting of this project. R-5734A is located adjacent to Maps #1, #2, and #6 thru #10.

U-5604 (C204216) is currently under construction and located in the vicinity of R-5734A.

The Contractor on this project shall cooperate with the Contractor working within or adjacent to the limits of this project to the extent that the work can be carried out to the best advantage of all concerned.

TWELVE MONTH GUARANTEE:

(7-15-03)

108

SP1 G145

- (A) The Contractor shall guarantee materials and workmanship against latent and patent defects arising from faulty materials, faulty workmanship or negligence for a period of twelve months following the date of final acceptance of the work for maintenance and shall replace such defective materials and workmanship without cost to the Department. The Contractor will not be responsible for damage due to faulty design, normal wear and tear, for negligence on the part of the Department, and/or for use in excess of the design.
- (B) Where items of equipment or material carry a manufacturer's guarantee for any period in excess of twelve months, then the manufacturer's guarantee shall apply for that particular piece of equipment or material. The Department's first remedy shall be through the manufacturer although the Contractor is responsible for invoking the warranted repair work with the manufacturer. The Contractor's responsibility shall be limited to the term of the manufacturer's guarantee. NCDOT would be afforded the same warranty as provided by the Manufacturer.

This guarantee provision shall be invoked only for major components of work in which the Contractor would be wholly responsible for under the terms of the contract. Examples would include pavement structures, bridge components, and sign structures. This provision will not be used as a mechanism to force the Contractor to return to the project to make repairs or perform additional work that the Department would normally compensate the Contractor for. In addition, routine maintenance activities (i.e. mowing grass, debris removal, ruts in earth shoulders,) are not parts of this guarantee.

Appropriate provisions of the payment and/or performance bonds shall cover this guarantee for the project.

To ensure uniform application statewide the Division Engineer will forward details regarding the circumstances surrounding any proposed guarantee repairs to the Chief Engineer for review and approval prior to the work being performed.

OUTSOURCING OUTSIDE THE USA:

(9-21-04) (Rev. 5-16-06)

SP1 G150

All work on consultant contracts, services contracts, and construction contracts shall be performed in the United States of America. No work shall be outsourced outside of the United States of America.

Outsourcing for the purpose of this provision is defined as the practice of subcontracting labor, work, services, staffing, or personnel to entities located outside of the United States.

The North Carolina Secretary of Transportation shall approve exceptions to this provision in writing.

EROSION AND SEDIMENT CONTROL/STORMWATER CERTIFICATION:

(1-16-07) (Rev 11-22-16)

105-16, 225-2, 16

SP1 G180

General

Schedule and conduct construction activities in a manner that will minimize soil erosion and the resulting sedimentation and turbidity of surface waters. Comply with the requirements herein regardless of whether or not a National Pollution discharge Elimination System (NPDES) permit for the work is required.

Establish a chain of responsibility for operations and subcontractors' operations to ensure that the *Erosion and Sediment Control/Stormwater Pollution Prevention Plan* is implemented and maintained over the life of the contract.

- (A) *Certified Supervisor* - Provide a certified Erosion and Sediment Control/Stormwater Supervisor to manage the Contractor and subcontractor operations, insure compliance with Federal, State and Local ordinances and regulations, and manage the Quality Control Program.
- (B) *Certified Foreman* - Provide a certified, trained foreman for each construction operation that increases the potential for soil erosion or the possible sedimentation and turbidity of surface waters.
- (C) *Certified Installer* - Provide a certified installer to install or direct the installation for erosion or sediment/stormwater control practices.
- (D) *Certified Designer* - Provide a certified designer for the design of the erosion and sediment control/stormwater component of reclamation plans and, if applicable, for the design of the project erosion and sediment control/stormwater plan.

Roles and Responsibilities

- (A) *Certified Erosion and Sediment Control/Stormwater Supervisor* - The Certified Supervisor shall be Level II and responsible for ensuring the erosion and sediment control/stormwater plan is adequately implemented and maintained on the project and for conducting the quality control program. The Certified Supervisor shall be on the project within 24 hours

notice from initial exposure of an erodible surface to the project's final acceptance. Perform the following duties:

- (1) Manage Operations - Coordinate and schedule the work of subcontractors so that erosion and sediment control/stormwater measures are fully executed for each operation and in a timely manner over the duration of the contract.
 - (a) Oversee the work of subcontractors so that appropriate erosion and sediment control/stormwater preventive measures are conformed to at each stage of the work.
 - (b) Prepare the required National Pollutant Discharge Elimination System (NPDES) Inspection Record and submit to the Engineer.
 - (c) Attend all weekly or monthly construction meetings to discuss the findings of the NPDES inspection and other related issues.
 - (d) Implement the erosion and sediment control/stormwater site plans requested.
 - (e) Provide any needed erosion and sediment control/stormwater practices for the Contractor's temporary work not shown on the plans, such as, but not limited to work platforms, temporary construction, pumping operations, plant and storage yards, and cofferdams.
 - (f) Acquire applicable permits and comply with requirements for borrow pits, dewatering, and any temporary work conducted by the Contractor in jurisdictional areas.
 - (g) Conduct all erosion and sediment control/stormwater work in a timely and workmanlike manner.
 - (h) Fully perform and install erosion and sediment control/stormwater work prior to any suspension of the work.
 - (i) Coordinate with Department, Federal, State and Local Regulatory agencies on resolution of erosion and sediment control/stormwater issues due to the Contractor's operations.
 - (j) Ensure that proper cleanup occurs from vehicle tracking on paved surfaces or any location where sediment leaves the Right-of-Way.
 - (k) Have available a set of erosion and sediment control/stormwater plans that are initialed and include the installation date of Best Management Practices. These practices shall include temporary and permanent groundcover and be properly updated to reflect necessary plan and field changes for use and review by Department personnel as well as regulatory agencies.
- (2) Requirements set forth under the NPDES Permit - The Department's NPDES Stormwater permit (NCS000250) outlines certain objectives and management measures pertaining to construction activities. The permit references *NCG010000, General Permit to Discharge Stormwater* under the NPDES, and states that the Department shall incorporate the applicable requirements into its delegated Erosion and Sediment Control Program for construction activities disturbing one or more acres of land. The Department further incorporates these requirements on all contracted bridge and culvert work at jurisdictional waters, regardless of size. Some of the requirements are, but are not limited to:

- (a) Control project site waste to prevent contamination of surface or ground waters of the state, i.e. from equipment operation/maintenance, construction materials, concrete washout, chemicals, litter, fuels, lubricants, coolants, hydraulic fluids, any other petroleum products, and sanitary waste.
 - (b) Inspect erosion and sediment control/stormwater devices and stormwater discharge outfalls at least once every 7 calendar days and within 24 hours after a rainfall event of 0.5 inch that occurs within a 24 hour period. Additional monitoring may be required at the discretion of Division of Water Resources personnel if the receiving stream is 303(d) listed for turbidity and the project has had documented problems managing turbidity.
 - (c) Maintain an onsite rain gauge or use the Department's Multi-Sensor Precipitation Estimate website to maintain a daily record of rainfall amounts and dates.
 - (d) Maintain erosion and sediment control/stormwater inspection records for review by Department and Regulatory personnel upon request.
 - (e) Implement approved reclamation plans on all borrow pits, waste sites and staging areas.
 - (f) Maintain a log of turbidity test results as outlined in the Department's Procedure for Monitoring Borrow Pit Discharge.
 - (g) Provide secondary containment for bulk storage of liquid materials.
 - (h) Provide training for employees concerning general erosion and sediment control/stormwater awareness, the Department's NPDES Stormwater Permit NCS000250 requirements, and the applicable requirements of the *General Permit, NCG010000*.
 - (i) Report violations of the NPDES permit to the Engineer immediately who will notify the Division of Water Quality Regional Office within 24 hours of becoming aware of the violation.
- (3) Quality Control Program - Maintain a quality control program to control erosion, prevent sedimentation and follow provisions/conditions of permits. The quality control program shall:
- (a) Follow permit requirements related to the Contractor and subcontractors' construction activities.
 - (b) Ensure that all operators and subcontractors on site have the proper erosion and sediment control/stormwater certification.
 - (c) Notify the Engineer when the required certified erosion and sediment control/stormwater personnel are not available on the job site when needed.
 - (d) Conduct the inspections required by the NPDES permit.
 - (e) Take corrective actions in the proper timeframe as required by the NPDES permit for problem areas identified during the NPDES inspections.
 - (f) Incorporate erosion control into the work in a timely manner and stabilize disturbed areas with mulch/seed or vegetative cover on a section-by-section basis.
 - (g) Use flocculants approved by state regulatory authorities where appropriate and where required for turbidity and sedimentation reduction.
 - (h) Ensure proper installation and maintenance of temporary erosion and sediment control devices.

- (i) Remove temporary erosion or sediment control devices when they are no longer necessary as agreed upon by the Engineer.
 - (j) The Contractor's quality control and inspection procedures shall be subject to review by the Engineer. Maintain NPDES inspection records and make records available at all times for verification by the Engineer.
- (B) *Certified Foreman* - At least one Certified Foreman shall be onsite for each type of work listed herein during the respective construction activities to control erosion, prevent sedimentation and follow permit provisions:
- (1) Foreman in charge of grading activities
 - (2) Foreman in charge of bridge or culvert construction over jurisdictional areas
 - (3) Foreman in charge of utility activities

The Contractor may request to use the same person as the Level II Supervisor and Level II Foreman. This person shall be onsite whenever construction activities as described above are taking place. This request shall be approved by the Engineer prior to work beginning.

The Contractor may request to name a single Level II Foreman to oversee multiple construction activities on small bridge or culvert replacement projects. This request shall be approved by the Engineer prior to work beginning.

- (C) *Certified Installers* - Provide at least one onsite, Level I Certified Installer for each of the following erosion and sediment control/stormwater crew:
- (1) Seeding and Mulching
 - (2) Temporary Seeding
 - (3) Temporary Mulching
 - (4) Sodding
 - (5) Silt fence or other perimeter erosion/sediment control device installations
 - (6) Erosion control blanket installation
 - (7) Hydraulic tackifier installation
 - (8) Turbidity curtain installation
 - (9) Rock ditch check/sediment dam installation
 - (10) Ditch liner/matting installation
 - (11) Inlet protection
 - (12) Riprap placement
 - (13) Stormwater BMP installations (such as but not limited to level spreaders, retention/detention devices)
 - (14) Pipe installations within jurisdictional areas

If a Level I *Certified Installer* is not onsite, the Contractor may substitute a Level II Foreman for a Level I Installer, provided the Level II Foreman is not tasked to another crew requiring Level II Foreman oversight.

- (D) *Certified Designer* - Include the certification number of the Level III-B Certified Designer on the erosion and sediment control/stormwater component of all reclamation plans and if

applicable, the certification number of the Level III-A Certified Designer on the design of the project erosion and sediment control/stormwater plan.

Preconstruction Meeting

Furnish the names of the *Certified Erosion and Sediment Control/Stormwater Supervisor*, *Certified Foremen*, *Certified Installers* and *Certified Designer* and notify the Engineer of changes in certified personnel over the life of the contract within 2 days of change.

Ethical Responsibility

Any company performing work for the North Carolina Department of Transportation has the ethical responsibility to fully disclose any reprimand or dismissal of an employee resulting from improper testing or falsification of records.

Revocation or Suspension of Certification

Upon recommendation of the Chief Engineer to the certification entity, certification for *Supervisor*, *Certified Foremen*, *Certified Installers* and *Certified Designer* may be revoked or suspended with the issuance of an *Immediate Corrective Action (ICA)*, *Notice of Violation (NOV)*, or *Cease and Desist Order* for erosion and sediment control/stormwater related issues.

The Chief Engineer may recommend suspension or permanent revocation of certification due to the following:

- (A) Failure to adequately perform the duties as defined within this certification provision.
- (B) Issuance of an ICA, NOV, or Cease and Desist Order.
- (C) Failure to fully perform environmental commitments as detailed within the permit conditions and specifications.
- (D) Demonstration of erroneous documentation or reporting techniques.
- (E) Cheating or copying another candidate's work on an examination.
- (F) Intentional falsification of records.
- (G) Directing a subordinate under direct or indirect supervision to perform any of the above actions.
- (H) Dismissal from a company for any of the above reasons.
- (I) Suspension or revocation of one's certification by another entity.

Suspension or revocation of a certification will be sent by certified mail to the certificant and the Corporate Head of the company that employs the certificant.

A certificant has the right to appeal any adverse action which results in suspension or permanent revocation of certification by responding, in writing, to the Chief Engineer within 10 calendar days after receiving notice of the proposed adverse action.

Chief Engineer
1536 Mail Service Center
Raleigh, NC 27699-1536

Failure to appeal within 10 calendar days will result in the proposed adverse action becoming effective on the date specified on the certified notice. Failure to appeal within the time specified will result in a waiver of all future appeal rights regarding the adverse action taken. The certificant will not be allowed to perform duties associated with the certification during the appeal process.

The Chief Engineer will hear the appeal and make a decision within 7 days of hearing the appeal. Decision of the Chief Engineer will be final and will be made in writing to the certificant.

If a certification is temporarily suspended, the certificant shall pass any applicable written examination and any proficiency examination, at the conclusion of the specified suspension period, prior to having the certification reinstated.

Measurement and Payment

Certified Erosion and Sediment Control/Stormwater Supervisor, Certified Foremen, Certified Installers and Certified Designer will be incidental to the project for which no direct compensation will be made.

PROCEDURE FOR MONITORING BORROW PIT DISCHARGE:

(2-20-07) (Rev. 3-19-13)

105-16, 230, 801

SP1 G181

Water discharge from borrow pit sites shall not cause surface waters to exceed 50 NTUs (nephelometric turbidity unit) in streams not designated as trout waters and 10 NTUs in streams, lakes or reservoirs designated as trout waters. For lakes and reservoirs not designated as trout waters, the turbidity shall not exceed 25 NTUs. If the turbidity exceeds these levels due to natural background conditions, the existing turbidity level shall not be increased.

If during any operating day, the downstream water quality exceeds the standard, the Contractor shall do all of the following:

- (A) Either cease discharge or modify the discharge volume or turbidity levels to bring the downstream turbidity levels into compliance, or
- (B) Evaluate the upstream conditions to determine if the exceedance of the standard is due to natural background conditions. If the background turbidity measurements exceed the standard, operation of the pit and discharge can continue as long as the stream turbidity levels are not increased due to the discharge.
- (C) Measure and record the turbidity test results (time, date and sampler) at all defined sampling locations 30 minutes after startup and at a minimum, one additional sampling of all sampling locations during that 24-hour period in which the borrow pit is discharging.
- (D) Notify DWQ within 24 hours of any stream turbidity standard exceedances that are not brought into compliance.

During the Environmental Assessment required by Article 230-4 of the *2018 Standard Specifications*, the Contractor shall define the point at which the discharge enters into the State's surface waters and the appropriate sampling locations. Sampling locations shall include points upstream and downstream from the point at which the discharge enters these waters. Upstream

sampling location shall be located so that it is not influenced by backwater conditions and represents natural background conditions. Downstream sampling location shall be located at the point where complete mixing of the discharge and receiving water has occurred.

The discharge shall be closely monitored when water from the dewatering activities is introduced into jurisdictional wetlands. Any time visible sedimentation (deposition of sediment) on the wetland surface is observed, the dewatering activity will be suspended until turbidity levels in the stilling basin can be reduced to a level where sediment deposition does not occur. Staining of wetland surfaces from suspended clay particles, occurring after evaporation or infiltration, does not constitute sedimentation. No activities shall occur in wetlands that adversely affect the functioning of a wetland. Visible sedimentation will be considered an indication of possible adverse impacts on wetland use.

The Engineer will perform independent turbidity tests on a random basis. These results will be maintained in a log within the project records. Records will include, at a minimum, turbidity test results, time, date and name of sampler. Should the Department's test results exceed those of the Contractor's test results, an immediate test shall be performed jointly with the results superseding the previous test results of both the Department and the Contractor.

The Contractor shall use the *NCDOT Turbidity Reduction Options for Borrow Pits Matrix*, available at http://www.ncdot.gov/doh/operations/dp_chief_eng/roadside/fieldops/downloads/Files/TurbidityReductionOptionSheet.pdf to plan, design, construct, and maintain BMPs to address water quality standards. Tier I Methods include stilling basins which are standard compensatory BMPs. Other Tier I methods are noncompensatory and shall be used when needed to meet the stream turbidity standards. Tier II Methods are also noncompensatory and are options that may be needed for protection of rare or unique resources or where special environmental conditions exist at the site which have led to additional requirements being placed in the DWQ's 401 Certifications and approval letters, Isolated Wetland Permits, Riparian Buffer Authorization or a DOT Reclamation Plan's Environmental Assessment for the specific site. Should the Contractor exhaust all Tier I Methods on a site exclusive of rare or unique resources or special environmental conditions, Tier II Methods may be required by regulators on a case by case basis per supplemental agreement.

The Contractor may use cation exchange capacity (CEC) values from proposed site borings to plan and develop the bid for the project. CEC values exceeding 15 milliequivalents per 100 grams of soil may indicate a high potential for turbidity and should be avoided when dewatering into surface water is proposed.

No additional compensation for monitoring borrow pit discharge will be paid.

PROJECT SPECIAL PROVISIONS**ROADWAY****CLEARING AND GRUBBING - METHOD II:**

(9-17-02) (Rev.8-18-15)

200

SP2 R02A

Perform clearing on this project to the limits established by Method "II" shown on Standard Drawing No. 200.02 of the *2018 Roadway Standard Drawings*. Conventional clearing methods may be used except where permit drawings or conditions have been included in the proposal which require certain areas to be cleared by hand methods.

SHOULDER AND FILL SLOPE MATERIAL:

(5-21-02)

235, 560

SP2 R45 A

Description

Perform the required shoulder and slope construction for this project in accordance with the applicable requirements of Section 560 and Section 235 of the *2018 Standard Specifications*.

Measurement and Payment

Where the material has been obtained from an authorized stockpile or from a borrow source and *Borrow Excavation* is not included in the contract, no direct payment will be made for this work, as the cost of this work will be part of the work being paid at the contract lump sum price for *Grading*. If *Borrow Excavation* is included in this contract and the material has been obtained from an authorized stockpile or from a borrow source, measurement and payment will be as provided in Section 230 of the *2018 Standard Specifications* for *Borrow Excavation*.

CURED-IN-PLACE PIPE:

Furnish and install pipe liner as shown at recommended locations on the plans. Pipe liner should be from NCDOT Approved Product Listing for drainage pipe liners at the following link or an approved equal:

<https://connect.ncdot.gov/resources/Products/Pages/default.aspx>

Pipe liner should maintain equivalent hydraulic conveyance as existing pipe. Pipe liner is subject to approval by the engineer.

___ "Cured-In-Place Pipe" will be measured and paid as the actual number of linear feet of pipe liner that has been incorporated into the completed and accepted work.

Pay Item

___ "Cured-In-Place Pipe

Pay Unit

Linear Foot

FLOWABLE FILL:

(9-17-02) (Rev 1-17-12)

300, 340, 1000, 1530, 1540, 1550

SP3 R30

Description

This work consists of all work necessary to place flowable fill in accordance with these provisions, the plans, and as directed.

Materials

Refer to Division 10 of the *2018 Standard Specifications*.

Item

Flowable Fill

Section

1000-6

Construction Methods

Discharge flowable fill material directly from the truck into the space to be filled, or by other approved methods. The mix may be placed full depth or in lifts as site conditions dictate. The Contractor shall provide a method to plug the ends of the existing pipe in order to contain the flowable fill.

Measurement and Payment

At locations where flowable fill is called for on the plans and a pay item for flowable fill is included in the contract, *Flowable Fill* will be measured in cubic yards and paid as the actual number of cubic yards that have been satisfactorily placed and accepted. Such price and payment will be full compensation for all work covered by this provision including, but not limited to, the mix design, furnishing, hauling, placing and containing the flowable fill.

Payment will be made under:

Pay Item

Flowable Fill

Pay Unit

Cubic Yard

BRIDGE APPROACH FILLS:

(10-19-10) (Rev. 1-16-18)

422

SP4 R02A

Description

Bridge approach fills consist of backfilling behind bridge end bents with select material or aggregate to support all or portions of bridge approach slabs. Install drains to drain water from bridge approach fills and geotextiles to separate approach fills from embankment fills, ABC and natural ground as required. For bridge approach fills behind end bents with mechanically stabilized earth (MSE) abutment walls, reinforce bridge approach fills with MSE wall reinforcement connected to end bent caps. Construct bridge approach fills in accordance with the contract, accepted submittals and 2018 Roadway Standard Drawing Nos. 422.01 or 422.02 or Roadway Detail Drawing No. 422D10.

Define bridge approach fill types as follows:

Approach Fills – Bridge approach fills in accordance with 2018 Roadway Standard Drawing Nos. 422.01 or 422.02 or Roadway Detail Drawing No. 422D10;

Standard Approach Fill – Type I Standard Bridge Approach Fill in accordance with 2018 Roadway Standard Drawing No. 422.01;

Modified Approach Fill – Type II Modified Bridge Approach Fill in accordance with 2018 Roadway Standard Drawing No. 422.02 and

Reinforced Approach Fill – Type III Reinforced Bridge Approach Fill in accordance with Roadway Detail Drawing No. 422D10.

Materials

Refer to Division 10 of the *2018 Standard Specifications*.

Item	Section
Geotextiles, Type 1	1056
Portland Cement Concrete	1000
Select Materials	1016
Subsurface Drainage Materials	1044

Provide Type 1 geotextile for separation geotextiles and Class B concrete for outlet pads. Use Class V or Class VI select material for standard and modified approach fills. For an approach fill behind a bridge end bent with an MSE abutment wall, backfill the reinforced approach fill with the same aggregate type approved for the reinforced zone in the accepted MSE wall submittal. For MSE wall aggregate, reinforcement and connector materials, see the *Mechanically Stabilized Earth Retaining Walls* provision. Provide PVC pipes, fittings and outlet pipes for subsurface drainage materials. For PVC drain pipes, use pipes with perforations that meet AASHTO M 278.

Construction Methods

Excavate as necessary for approach fills in accordance with the contract. Notify the Engineer when foundation excavation is complete. Do not place separation geotextiles or aggregate until approach fill dimensions and foundation material are approved.

For reinforced approach fills, cast MSE wall reinforcement or connectors into end bent cap backwalls within 3" of locations shown in the accepted MSE wall submittals. Install MSE wall reinforcement with the orientation, dimensions and number of layers shown in the accepted MSE wall submittals. If a reinforced approach fill is designed with geogrid reinforcement embedded in an end bent cap, cut geogrids to the required lengths and after securing ends of geogrids in place, reroll and rewrap portions of geogrids not embedded in the cap to protect geogrids from damage. Before placing aggregate, pull geosynthetic reinforcement taut so that it is in tension and free of kinks, folds, wrinkles or creases.

Attach separation geotextiles to end bent cap backwalls and wing walls with adhesives, tapes or other approved methods. Overlap adjacent separation geotextiles at least 18" with seams oriented

parallel to the roadway centerline. Hold geotextiles in place with wire staples or anchor pins as needed. Contact the Engineer when existing or future obstructions such as foundations, pavements, pipes, inlets or utilities will interfere with separation geotextiles or MSE wall reinforcement.

Install continuous perforated PVC drain pipes with perforations pointing down in accordance with 2018 Roadway Standard Drawing Nos. 422.01 or 422.02. Connect drain pipes to outlet pipes just beyond wing walls. Connect PVC pipes, fittings and outlet pipes with solvent cement in accordance with Article 815-3 of the *2018 Standard Specifications* and place outlet pads in accordance with 2018 Roadway Standard Drawing No. 815.03.

Install drain pipes so water drains towards outlets. If the groundwater elevation is above drain pipe elevations, raise drains up to maintain positive drainage towards outlets. Place pipe sleeves in or under wing walls so water drains towards outlets. Use sleeves that can withstand wing wall loads.

Place select material or aggregate in 8" to 10" thick lifts. Compact fine aggregate for reinforced approach fills in accordance with Subarticle 235-3(C) of the *2018 Standard Specifications* except compact fine aggregate to a density of at least 98%. Compact select material for standard or modified approach fills and coarse aggregate for reinforced approach fills with a vibratory compactor to the satisfaction of the Engineer. Do not displace or damage geosynthetics, MSE wall reinforcement or drains when placing and compacting select material or aggregate. End dumping directly on geosynthetics is not permitted. Do not operate heavy equipment on geosynthetics or drain pipes until they are covered with at least 8" of select material or aggregate. Replace any damaged geosynthetics or drains to the satisfaction of the Engineer. When approach fills extend beyond bridge approach slabs, wrap separation geotextiles over select material or aggregate as shown in 2018 Roadway Standard Drawing No. 422.01 or 2018 Roadway Detail Drawing No. 422D10.

Measurement and Payment

Type I Standard Approach Fill, Station ____, *Type II Modified Approach Fill, Station ____* and *Type III Reinforced Approach Fill, Station ____* will be paid at the contract lump sum price. The lump sum price for each approach fill will be full compensation for providing labor, tools, equipment and approach fill materials, excavating, backfilling, hauling and removing excavated materials, installing geotextiles and drains, compacting backfill and supplying select material, aggregate, separation geotextiles, drain pipes, pipe sleeves, outlet pipes and pads and any incidentals necessary to construct approach fills behind bridge end bents.

The contract lump sum price for *Type III Reinforced Approach Fill, Station ____* will also be full compensation for supplying and connecting MSE wall reinforcement to end bent caps but not designing MSE wall reinforcement and connectors. The cost of designing reinforcement and connectors for reinforced approach fills behind bridge end bents with MSE abutment walls will be incidental to the contract unit price for *MSE Retaining Wall No. ____*.

Payment will be made under:

Pay Item

Type I Standard Approach Fill, Station ____
 Type II Modified Approach Fill, Station ____
 Type III Reinforced Approach Fill, Station ____

Pay Unit

Lump Sum
 Lump Sum
 Lump Sum

EXISTING BRIDGE PLAQUE (17BP.14.R.154)

(10-24-17)

Description

Remove and deliver the existing bridge plaque(s) and rail(s) to the Town of Franklin, North Carolina to the location directed by the Engineer.

Construction Methods

Remove the existing bridge plaque and rail intact using methods that will not damage the plaque and rail approved by the Engineer. The plaque(s) and rail(s) shall be placed on a pallet and delivered to a location directed by the Engineer within the Town of Franklin North Carolina.

Measurement and Payment

The Removal and delivery of the Bridge Plaque and Column shall be included and incidental to the pay item for “Removal of Existing Structure at station 14+94.00 –L-”; including all labor, equipment, tools, delivery, and materials necessary to remove and deliver the plaque(s) and rail(s).

AGGREGATE SUBGRADE:

(5-15-18)

505

SP5 R8

Revise the *2018 Standard Specifications* as follows:

Page 5-8, Article 505-1 DESCRIPTION, lines 4-6, replace the paragraph with the following:

Construct aggregate subgrades in accordance with the contract. Install geotextile for soil stabilization and place Class IV subgrade stabilization at locations shown in the plans and as directed.

Undercut natural soil materials if necessary to construct aggregate subgrades. Define “subbase” as the portion of the roadbed below the Class IV subgrade stabilization. For Type 2 aggregate subgrades, undercut subbases as needed. The types of aggregate subgrade with thickness and compaction requirements for each are as shown below.

Type 1 – A 6 to 24 inch thick aggregate subgrade with Class IV subgrade stabilization compacted to 92% of AASHTO T 180 as modified by the Department or to the highest density that can be reasonably obtained.

Type 2 – An 8 inch thick aggregate subgrade on a proof rolled subbase with Class IV subgrade stabilization compacted to 97% of AASHTO T 180 as modified by the Department.

Page 5-8, Article 505-3 CONSTRUCTION METHODS, line 12, insert the following after the first sentence of the first paragraph:

For Type 2 aggregate subgrades, proof roll subbases in accordance with Section 260 before installing geotextile for soil stabilization.

Page 5-8, Article 505-3 CONSTRUCTION METHODS, lines 16-17, replace the last sentence

of the first paragraph with the following:

Compact ABC as required for the type of aggregate subgrade constructed.

Page 5-8, Article 505-4 MEASUREMENT AND PAYMENT, line 26, insert the following after the last sentence of the first paragraph:

Undercut Excavation of natural soil materials from subbases for Type 2 aggregate subgrades will be measured and paid in accordance with Article 225-7 or 226-3. No measurement will be made for any undercut excavation of fill materials from subbases.

PRICE ADJUSTMENT - ASPHALT BINDER FOR PLANT MIX:

(11-21-00)

620

SP6 R25

Price adjustments for asphalt binder for plant mix will be made in accordance with Section 620 of the *2018 Standard Specifications*.

The base price index for asphalt binder for plant mix is **\$ 562.78** per ton.

This base price index represents an average of F.O.B. selling prices of asphalt binder at supplier's terminals on **October 1, 2018**.

ASPHALT CONCRETE PLANT MIX PAVEMENTS:

(2-20-18)

610, 1012

SP6 R65

Revise the *2018 Standard Specifications* as follows:

Page 6-17, Table 610-1, MIXING TEMPERATURE AT THE ASPHALT PLANT, replace with the following:

TABLE 610-1	
MIXING TEMPERATURE AT THE ASPHALT PLANT	
Binder Grade	JMF Temperature
PG 58-28; PG 64-22	250 - 290°F
PG 76-22	300 - 325°F

Page 6-17, Subarticle 610-3(C), Job Mix Formula (JMF), lines 38-39, delete the fourth paragraph.

Page 6-18, Subarticle 610-3(C), Job Mix Formula (JMF), line 12, replace “SF9.5A” with “S9.5B”.

Page 6-18, Table 610-3, MIX DESIGN CRITERIA, replace with the following:

TABLE 610-3 MIX DESIGN CRITERIA									
Mix Type	Design ESALs millions ^A	Binder PG Grade ^B	Compaction Levels		Max. Rut Depth (mm)	Volumetric Properties			
			Gmm @			VMA % Min.	VTM %	VFA Min.-Max.	%Gmm @ Nini
			Nini	Ndes					
S4.75A	< 1	64 - 22	6	50	11.5	16.0	4.0 - 6.0	65 - 80	≤ 91.5
S9.5B	0 - 3	64 - 22	6	50	9.5	16.0	3.0 - 5.0	70 - 80	≤ 91.5
S9.5C	3 - 30	64 - 22	7	65	6.5	15.5	3.0 - 5.0	65 - 78	≤ 90.5
S9.5D	> 30	76 - 22	8	100	4.5	15.5	3.0 - 5.0	65 - 78	≤ 90.0
I19.0C	ALL	64 - 22	7	65	-	13.5	3.0 - 5.0	65 - 78	≤ 90.5
B25.0C	ALL	64 - 22	7	65	-	12.5	3.0 - 5.0	65 - 78	≤ 90.5
Design Parameter					Design Criteria				
All Mix Types	Dust to Binder Ratio ($P_{0.075} / P_{be}$)				0.6 - 1.4 ^C				
	Tensile Strength Ratio (TSR) ^D				85% Min. ^E				

- A. Based on 20 year design traffic.
- B. Volumetric Properties based on specimens compacted to N_{des} as modified by the Department.
- C. Dust to Binder Ratio ($P_{0.075} / P_{be}$) for Type S4.75A is 1.0 - 2.0.
- D. NCDOT-T-283 (No Freeze-Thaw cycle required).
- E. TSR for Type S4.75A & B25.0C mixes is 80% minimum.

Page 6-19, Table 610-5, BINDER GRADE REQUIREMENTS (BASED ON RBR%), replace with the following:

TABLE 610-5 BINDER GRADE REQUIREMENTS (BASED ON RBR%)			
Mix Type	%RBR ≤ 20%	21% ≤ %RBR ≤ 30%	%RBR > 30%
S4.75A, S9.5B, S9.5C, I19.0C, B25.0C	PG 64-22	PG 64-22 ^A	PG 58-28
S9.5D, OGFC	PG 76-22 ^B	n/a	n/a

- A. If the mix contains any amount of RAS, the virgin binder shall be PG 58-28.
- B. Maximum Recycled Binder Replacement (%RBR) is 18% for mixes using PG 76-22 binder.

Page 6-20, Table 610-6, PLACEMENT TEMPERATURES FOR ASPHALT, replace with the following:

TABLE 610-6 PLACEMENT TEMPERATURES FOR ASPHALT	
Asphalt Concrete Mix Type	Minimum Surface and Air Temperature
B25.0C	35°F
I19.0C	35°F
S4.75A, S9.5B, S9.5C	40°F ^A
S9.5D	50°F

- A. For the final layer of surface mixes containing recycled asphalt shingles (RAS), the minimum surface and air temperature shall be 50° F.

Page 6-23, Table 610-7, DENSITY REQUIREMENTS, replace with the following:

Mix Type	Minimum % G_{mm} (Maximum Specific Gravity)
S4.75A	85.0 ^A
S9.5B	90.0
S9.5C, S9.5D, I19.0C, B25.0C	92.0

- A. Compaction to the above specified density will be required when the S4.75A mix is applied at a rate of 100 lbs/sy or higher.

Page 6-32, Article 610-16 MEASUREMENT AND PAYMENT, replace with the following:

Pay Item	Pay Unit
Asphalt Concrete Base Course, Type B25.0C	Ton
Asphalt Concrete Intermediate Course, Type I19.0C	Ton
Asphalt Concrete Surface Course, Type S4.75A	Ton
Asphalt Concrete Surface Course, Type S9.5B	Ton
Asphalt Concrete Surface Course, Type S9.5C	Ton
Asphalt Concrete Surface Course, Type S9.5D	Ton

Page 10-30, Table 1012-1, AGGREGATE CONSENSUS PROPERTIES, replace with the following:

Mix Type	Coarse Aggregate Angularity^B	Fine Aggregate Angularity % Minimum	Sand Equivalent % Minimum	Flat and Elongated 5 : 1 Ratio % Maximum
<i>Test Method</i>	<i>ASTM D5821</i>	<i>AASHTO T 304</i>	<i>AASHTO T 176</i>	<i>ASTM D4791</i>
S4.75A; S9.5B	75 / -	40	40	-
S9.5C; I19.0C; B25.0C	95 / 90	45	45	10
S9.5D	100 / 100	45	50	10
OGFC	100 / 100	45	45	10
UBWC	100 / 85	45	45	10

- A. Requirements apply to the design aggregate blend.
 B. 95 / 90 denotes that 95% of the coarse aggregate has one fractured face and 90% has 2 or more fractured faces.

MODIFIED CONCRETE FLUME WITH CONCRETE OUTLET:

(3-19-96)(Rev. 6-17-08)

825

SP8 R10

At locations shown in the plans, construct concrete flumes, concrete curb, and apron in accordance with the details in the plans. Use materials meeting the requirements of Section 825 of the 2018 Standard Specifications except that the concrete must be Class B or of higher compressive strength.

Each concrete flume, concrete curb, and apron completed and accepted will be paid at the contract unit price per each for *Modified Concrete Flume*. Such price and payment will be full compensation for all materials, labor, equipment, tools, removing and disposing of the temporary slope drains, and any other incidentals necessary to complete the work satisfactorily.

The concrete curb and ditch outside the pay limits of the apron will be measured and paid in accordance with Section 846 and 850 of the *2018 Standard Specifications*.

Payment will be made under:

Pay Item	Pay Unit
Modified Concrete Flume	Each

REINFORCED CONCRETE DRIVEWAY:

Description

Construct Reinforced Concrete Driveway in accordance with Section 848 of the *Standard Specifications* as modified by the typical section and detail in the plans and this provision.

Materials

Concrete shall be Class A Concrete meeting the requirements of Section 1000 of the *Standard Specifications*.

Wire mesh reinforcement shall be welded wire fabric meeting the requirements of Section 1070 of the *Standard Specifications*.

Measurement and Payment

Reinforced Concrete Driveway will be measured and paid for in square yards of Reinforced Concrete Driveway that have completed and accepted. Such price and payment will be full compensation for all work of constructing the driveway, including but not limited to excavating and backfilling, furnishing and placing concrete, and constructing joints.

Pay Item	Pay Unit
Reinforced Concrete Driveway	Square Yard

CONVERT EXISTING CATCH BASIN TO TRAFFIC BEARING JUNCTION BOX:

(1-1-02) (Rev. 7-18-06)

840, 859

SP8 R50

At the proper phase of construction, convert the existing catch basin at locations indicated in the plans or where directed, to traffic bearing junction box in accordance with the details in the plans and the applicable requirements of Sections 840 and 859 of the *2018 Standard Specifications*.

Convert Existing Catch Basin to Traffic Bearing Junction Box will be measured and paid as each, completed and accepted. Such price and payment is considered full compensation for all

equipment, materials, labor, tools, and incidentals necessary to complete each conversion satisfactorily.

Payment will be made under:

Pay Item

Convert Existing Catch Basin to Traffic Bearing Junction Box

Pay Unit

Each

GUARDRAIL END UNITS, TYPE - TL-2:

(10-21-08) (Rev. 7-1-17)

862

SP8 R64

Description

Furnish and install guardrail end units in accordance with the details in the plans, the applicable requirements of Section 862 of the *2018 Standard Specifications*, and at locations shown in the plans.

Materials

Furnish guardrail end units listed on the NCDOT [Approved Products List](https://apps.dot.state.nc.us/vendor/approvedproducts/) at <https://apps.dot.state.nc.us/vendor/approvedproducts/> or approved equal.

Prior to installation the Contractor shall submit to the Engineer:

- (A) FHWA acceptance letter for each guardrail end unit certifying it meets the requirements of the AASHTO Manual for Assessing Safety Hardware, Test Level 2 in accordance with Article 106-2 of the *2018 Standard Specifications*.
- (B) Certified working drawings and assembling instructions from the manufacturer for each guardrail end unit in accordance with Article 105-2 of the *2018 Standard Specifications*.

No modifications shall be made to the guardrail end unit without the express written permission from the manufacturer. Perform installation in accordance with the details in the plans, and details and assembling instructions furnished by the manufacturer.

Construction Methods

Guardrail end delineation is required on all approach and trailing end sections for both temporary and permanent installations. Guardrail end delineation consists of yellow reflective sheeting applied to the entire end section of the guardrail in accordance with Article 1088-3 of the *2018 Standard Specifications* and is incidental to the cost of the guardrail end unit.

Measurement and Payment

Measurement and payment will be made in accordance with Article 862-6 of the *2018 Standard Specifications*.

Payment will be made under:

Pay Item

Guardrail End Units, Type TL-2

Pay Unit

Each

GUARDRAIL END UNITS, TYPE - TL-3:

(4-20-04) (Rev. 7-1-17)

862

SP8 R65

Description

Furnish and install guardrail end units in accordance with the details in the plans, the applicable requirements of Section 862 of the *2018 Standard Specifications*, and at locations shown in the plans.

Materials

Furnish guardrail end units listed on the NCDOT Approved Products List at <https://apps.dot.state.nc.us/vendor/approvedproducts/> or approved equal.

Prior to installation the Contractor shall submit to the Engineer:

- (A) FHWA acceptance letter for each guardrail end unit certifying it meets the requirements of the AASHTO Manual for Assessing Safety Hardware, Test Level 3, in accordance with Article 106-2 of the *2018 Standard Specifications*.
- (B) Certified working drawings and assembling instructions from the manufacturer for each guardrail end unit in accordance with Article 105-2 of the *2018 Standard Specifications*.

No modifications shall be made to the guardrail end unit without the express written permission from the manufacturer. Perform installation in accordance with the details in the plans, and details and assembling instructions furnished by the manufacturer.

Construction Methods

Guardrail end delineation is required on all approach and trailing end sections for both temporary and permanent installations. Guardrail end delineation consists of yellow reflective sheeting applied to the entire end section of the guardrail in accordance with Article 1088-3 of the *2018 Standard Specifications* and is incidental to the cost of the guardrail end unit.

Measurement and Payment

Measurement and payment will be made in accordance with Article 862-6 of the *2018 Standard Specifications*.

Payment will be made under:

Pay Item

Guardrail End Units, Type TL-3

Pay Unit

Each

GUARDRAIL ANCHOR UNITS AND TEMPORARY GUARDRAIL ANCHOR UNITS:

(1-16-2018)

862

SP8 R70

Guardrail anchor units will be in accordance with the details in the plans and the applicable requirements of Section 862 of the *2018 Standard Specifications*.

Revise the *2018 Standard Specifications* as follows:

Page 8-42, Article 862-6 MEASUREMENT AND PAYMENT, add the following:

Guardrail Anchor Units, Type ___ and Temporary Guardrail Anchor Units Type ___ will be measured and paid as units of each completed and accepted. No separate measurement will be made of any rail, terminal sections, posts, offset blocks, concrete, hardware or any other components of the completed unit that are within the pay limits shown in the plans for the unit as all such components will be considered to be part of the unit.

Payment will be made under:

Pay Item	Pay Unit
Guardrail Anchor Units, Type _____	Each
Temporary Guardrail Anchor Units, Type _____	Each

GUARDRAIL POST CAPS:**Description**

Provide and install guardrail post caps in accordance with the contract documents and as directed by the Engineer.

Materials

Guardrail post caps shall be plastic or other approved material and shall fit securely on top of the guardrail post. Guardrail post caps shall be attached in a manner that prevents inadvertent or unauthorized removal. Guardrail post caps shall be of a design that protects pedestrians from the top of the guardrail post. Guardrail post caps shall be similar in design to those used on NCDOT Project R-2519A (C202332) US-19 East near Burnsville. The contractor is not restricted to any particular manufacturer or product, but the guardrail post cap to be installed is subject to approval by the Engineer.

Measurement and Payment

Guardrail Post Caps will be measured and paid for per each that are furnished, installed and accepted. Such price and payment will be full compensation for all labor, materials and incidentals necessary to complete the work described in this special provision.

Payment will be made under:

Pay Item	Pay Unit
Guardrail Post Caps	Each

WALL MOUNTED PEDESTRIAN HANDRAIL:**Description**

Furnish and install wall mounted pedestrian handrail at the locations shown in the plans, in accordance with the contract documents and as directed by the Engineer.

Measurement and Payment

Wall Mounted Pedestrian Handrail will be measured and paid for as the actual number of linear feet of safety rail measured along the top of the rail to the nearest 0.1 of a foot. Such price and payment shall be full compensation for fabricating, furnishing, installing, painting and all incidentals necessary to satisfactorily install the safety rail.

Payment will be made under:

Pay Item	Pay Unit
Wall Mounted Pedestrian Handrail	Linear Foot

FOUNDATIONS AND ANCHOR ROD ASSEMBLIES FOR METAL POLES:

(1-17-12) (Rev. 1-16-18)

9, 14, 17

SP9 R05

Description

Foundations for metal poles include foundations for signals, cameras, overhead and dynamic message signs (DMS) and high mount and light standards supported by metal poles or upright trusses. Foundations consist of footings with pedestals and drilled piers with or without grade beams or wings. Anchor rod assemblies consist of anchor rods (also called anchor bolts) with nuts and washers on the exposed ends of rods and nuts and a plate or washers on the other ends of rods embedded in the foundation.

Construct concrete foundations with the required resistances and dimensions and install anchor rod assemblies in accordance with the contract and accepted submittals. Construct drilled piers consisting of cast-in-place reinforced concrete cylindrical sections in excavated holes. Provide temporary casings or polymer slurry as needed to stabilize drilled pier excavations. Use a prequalified Drilled Pier Contractor to construct drilled piers for metal poles. Define "excavation" and "hole" as a drilled pier excavation and "pier" as a drilled pier.

This provision does not apply to foundations for signal pedestals; see Section 1743 of the *2018 Standard Specifications* and 2018 Roadway Standard Drawing No. 1743.01.

Materials

Refer to the *2018 Standard Specifications*.

Item	Section
Conduit	1091-3
Grout, Type 2	1003

Item	Section
Polymer Slurry	411-2(B)(2)
Portland Cement Concrete	1000
Reinforcing Steel	1070
Rollers and Chairs	411-2(C)
Temporary Casings	411-2(A)

Provide Type 3 material certifications in accordance with Article 106-3 of the *2018 Standard Specifications* for conduit, rollers, chairs and anchor rod assemblies. Store steel materials on blocking at least 12" above the ground and protect it at all times from damage; and when placing in the work make sure it is free from dirt, dust, loose mill scale, loose rust, paint, oil or other foreign materials. Load, transport, unload and store foundation and anchor rod assembly materials so materials are kept clean and free of damage. Bent, damaged or defective materials will be rejected.

Use conduit type in accordance with the contract. Use Class A concrete for footings and pedestals, Class Drilled Pier concrete for drilled piers and Class AA concrete for grade beams and wings including portions of drilled piers above bottom of wings elevations. Corrugated temporary casings may be accepted at the discretion of the Engineer. A list of approved polymer slurry products is available from:

connect.ncdot.gov/resources/Geological/Pages/Products.aspx

Provide anchor rod assemblies in accordance with the contract consisting of the following:

- (A) Straight anchor rods,
- (B) Heavy hex top and leveling nuts and flat washers on exposed ends of rods, and
- (C) Nuts and either flat plates or washers on the other ends of anchor rods embedded in foundations.

Do not use lock washers. Use steel anchor rods, nuts and washers that meet ASTM F1554 for Grade 55 rods and Grade A nuts. Use steel plates and washers embedded in concrete with a thickness of at least 1/4". Galvanize anchor rods and exposed nuts and washers in accordance with Article 1076-4 of the *2018 Standard Specifications*. It is not necessary to galvanize nuts, plates and washers embedded in concrete.

Construction Methods

Install the required size and number of conduits in foundations in accordance with the plans and accepted submittals. Construct top of piers, footings, pedestals, grade beams and wings flat, level and within 1" of elevations shown in the plans or approved by the Engineer. Provide an Ordinary Surface finish in accordance with Subarticle 825-6(B) of the *2018 Standard Specifications* for portions of foundations exposed above finished grade. Do not remove anchor bolt templates or pedestal or grade beam forms or erect metal poles or upright trusses onto foundations until concrete attains a compressive strength of at least 3,000 psi.

(A) Drilled Piers

Before starting drilled pier construction, hold a predrill meeting to discuss the installation, monitoring and inspection of the drilled piers. Schedule this meeting after the Drilled Pier Contractor has mobilized to the site. The Resident or Division Traffic Engineer, Contractor and Drilled Pier Contractor Superintendent will attend this predrill meeting.

Do not excavate holes, install piles or allow equipment wheel loads or vibrations within 20 ft of completed piers until 16 hours after Drilled Pier concrete reaches initial set.

Check for correct drilled pier alignment and location before beginning drilling. Check plumbness of holes frequently during drilling.

Construct drilled piers with the minimum required diameters shown in the plans. Install piers with tip elevations no higher than shown in the plans or approved by the Engineer.

Excavate holes with equipment of the sizes required to construct drilled piers. Depending on the subsurface conditions encountered, drilling through rock and boulders may be required. Do not use blasting for drilled pier excavations.

Contain and dispose of drilling spoils and waste concrete as directed and in accordance with Section 802 of the *2018 Standard Specifications*. Drilling spoils consist of all materials and fluids removed from excavations.

If unstable, caving or sloughing materials are anticipated or encountered, stabilize holes with temporary casings and/or polymer slurry. Do not use telescoping temporary casings. If it becomes necessary to replace a temporary casing during drilling, backfill the excavation, insert a larger casing around the casing to be replaced or stabilize the excavation with polymer slurry before removing the temporary casing.

If temporary casings become stuck or the Contractor proposes leaving casings in place, temporary casings should be installed against undisturbed material. Unless otherwise approved, do not leave temporary casings in place for mast arm poles and cantilever signs. The Engineer will determine if casings may remain in place. If the Contractor proposes leaving temporary casings in place, do not begin drilling until a casing installation method is approved.

Use polymer slurry and additives to stabilize holes in accordance with the slurry manufacturer's recommendations. Provide mixing water and equipment suitable for polymer slurry. Maintain the required slurry properties at all times except for sand content.

Define a "sample set" as slurry samples collected from mid-height and within 2 ft of the bottom of holes. Take sample sets from excavations to test polymer slurry immediately after filling holes with slurry, at least every 4 hours thereafter and immediately before placing concrete. Do not place Drilled Pier concrete until both slurry samples from an excavation meet the required polymer slurry properties. If any slurry test results do not meet the requirements, the Engineer may suspend drilling until both samples from a sample set meet the required polymer slurry properties.

Remove soft and loose material from bottom of holes using augers to the satisfaction of the Engineer. Assemble rebar cages and place cages and Drilled Pier concrete in accordance with Subarticle 411-4(E) of the *2018 Standard Specifications* except for the following:

- (1) Inspections for tip resistance and bottom cleanliness are not required,
- (2) Temporary casings may remain in place if approved, and
- (3) Concrete placement may be paused near the top of pier elevations for anchor rod assembly installation and conduit placement or
- (4) If applicable, concrete placement may be stopped at bottom of grade beam or wings elevations for grade beam or wing construction.

If wet placement of concrete is anticipated or encountered, do not place Drilled Pier concrete until a concrete placement procedure is approved. If applicable, temporary casings and fluids may be removed when concrete placement is paused or stopped in accordance with the exceptions above provided holes are stable. Remove contaminated concrete from exposed Drilled Pier concrete after removing casings and fluids. If holes are unstable, do not remove temporary casings until a procedure for placing anchor rod assemblies and conduit or constructing grade beams or wings is approved.

Use collars to extend drilled piers above finished grade. Remove collars after Drilled Pier concrete sets and round top edges of piers.

If drilled piers are questionable, pile integrity testing (PIT) and further investigation may be required in accordance with Article 411-5 of the *2018 Standard Specifications*. A drilled pier will be considered defective in accordance with Subarticle 411-5(D) of the *2018 Standard Specifications* and drilled pier acceptance is based in part on the criteria in Article 411-6 of the *2018 Standard Specifications* except for the top of pier tolerances in Subarticle 411-6(C) of the *2018 Standard Specifications*.

If a drilled pier is under further investigation, do not grout core holes, backfill around the pier or perform any work on the drilled pier until the Engineer accepts the pier. If the drilled pier is accepted, dewater and grout core holes and backfill around the pier with approved material to finished grade. If the Engineer determines a pier is unacceptable, remediation is required in accordance with Article 411-6 of the *2018 Standard Specifications*. No extension of completion date or time will be allowed for remediation of unacceptable drilled piers or post repair testing.

Permanently embed a plate in or mark top of piers with the pier diameter and depth, size and number of vertical reinforcing bars and the minimum compressive strength of the concrete mix at 28 days.

(B) Footings, Pedestals, Grade Beams and Wings

Excavate as necessary for footings, grade beams and wings in accordance with the plans, accepted submittals and Section 410 of the *2018 Standard Specifications*. If unstable, caving or sloughing materials are anticipated or encountered, shore foundation excavations

as needed with an approved method. Notify the Engineer when foundation excavation is complete. Do not place concrete or reinforcing steel until excavation dimensions and foundation material are approved.

Construct cast-in-place reinforced concrete footings, pedestals, grade beams and wings with the dimensions shown in the plans and in accordance with Section 825 of the *2018 Standard Specifications*. Use forms to construct portions of pedestals and grade beams protruding above finished grade. Provide a chamfer with a 3/4" horizontal width for pedestal and grade beam edges exposed above finished grade. Place concrete against undisturbed soil or backfill and fill in accordance with Article 410-8 of the *2018 Standard Specifications*. Proper compaction around footings and wings is critical for foundations to resist uplift and torsion forces.

(C) Anchor Rod Assemblies

Size anchor rods for design and the required projection above top of foundations. Determine required anchor rod projections from nut, washer and base plate thicknesses, the protrusion of 3 to 5 anchor rod threads above top nuts after tightening and the distance of one nut thickness between top of foundations and bottom of leveling nuts.

Protect anchor rod threads from damage during storage and installation of anchor rod assemblies. Before placing anchor rods in foundations, turn nuts onto and off rods past leveling nut locations. Turn nuts with the effort of one workman using an ordinary wrench without a cheater bar. Report any thread damage to the Engineer that requires extra effort to turn nuts.

Arrange anchor rods symmetrically about center of base plate locations as shown in the plans. Set anchor rod elevations based on required projections above top of foundations. Securely brace and hold rods in the correct position, orientation and alignment with a steel template. Do not weld to reinforcing steel, temporary casings or anchor rods.

Install top and leveling (bottom) nuts, washers and the base plate for each anchor rod assembly in accordance with the following procedure:

- (1) Turn leveling nuts onto anchor rods to a distance of one nut thickness between the top of foundation and bottom of leveling nuts. Place washers over anchor rods on top of leveling nuts.
- (2) Determine if nuts are level using a flat rigid template on top of washers. If necessary, lower leveling nuts to level the template in all directions or if applicable, lower nuts to tilt the template so the metal pole or upright truss will lean as shown in the plans. If leveling nuts and washers are not in full contact with the template, replace washers with galvanized beveled washers.
- (3) Verify the distance between the foundation and leveling nuts is no more than one nut thickness.
- (4) Place base plate with metal pole or upright truss over anchor rods on top of washers. High mount luminaires may be attached before erecting metal poles but do not attach cables, mast arms or trusses to metal poles or upright trusses at this time.

- (5) Place washers over anchor rods on top of base plate. Lubricate top nut bearing surfaces and exposed anchor rod threads above washers with beeswax, paraffin or other approved lubricant.
- (6) Turn top nuts onto anchor rods. If nuts are not in full contact with washers or washers are not in full contact with the base plate, replace washers with galvanized beveled washers.
- (7) Tighten top nuts to snug-tight with the full effort of one workman using a 12" wrench. Do not tighten any nut all at once. Turn top nuts in increments. Follow a star pattern cycling through each nut at least twice.
- (8) Repeat (7) for leveling nuts.
- (9) Replace washers above and below the base plate with galvanized beveled washers if the slope of any base plate face exceeds 1:20 (5%), any washer is not in firm contact with the base plate or any nut is not in firm contact with a washer. If any washers are replaced, repeat (7) and (8).
- (10) With top and leveling nuts snug-tight, mark each top nut on a corner at the intersection of 2 flats and a corresponding reference mark on the base plate. Mark top nuts and base plate with ink or paint that is not water-soluble. Use the turn-of-nut method for pretensioning. Do not pretension any nut all at once. Turn top nuts in increments for a total turn that meets the following nut rotation requirements:

NUT ROTATION REQUIREMENTS (Turn-of-Nut Pretensioning Method)	
Anchor Rod Diameter, inch	Requirement
$\leq 1 \frac{1}{2}$	1/3 turn (2 flats)
$> 1 \frac{1}{2}$	1/6 turn (1 flat)

Follow a star pattern cycling through each top nut at least twice.

- (11) Ensure nuts, washers and base plate are in firm contact with each other for each anchor rod. Cables, mast arms and trusses may now be attached to metal poles and upright trusses.
- (12) Between 4 and 14 days after pretensioning top nuts, use a torque wrench calibrated within the last 12 months to check nuts in the presence of the Engineer. Completely erect mast arm poles and cantilever signs and attach any hardware before checking top nuts for these structures. Check that top nuts meet the following torque requirements:

TORQUE REQUIREMENTS	
Anchor Rod Diameter, inch	Requirement, ft-lb
7/8	180
1	270
1 1/8	380
1 1/4	420
$\geq 1 \frac{1}{2}$	600

If necessary, retighten top nuts in the presence of the Engineer with a calibrated torque wrench to within ± 10 ft-lb of the required torque. Do not overtighten top nuts.

- (13) Do not grout under base plate.

Measurement and Payment

Foundations and anchor rod assemblies for metal poles and upright trusses will be measured and paid for elsewhere in the contract.

No payment will be made for temporary casings that remain in drilled pier excavations. No payment will be made for PIT. No payment will be made for further investigation of defective piers. Further investigation of piers that are not defective will be paid as extra work in accordance with Article 104-7 of the *2018 Standard Specifications*. No payment will be made for remediation of unacceptable drilled piers or post repair testing.

HIGH STRENGTH CONCRETE FOR DRIVEWAYS:

(11-21-00) (Rev. 1-17-12)

848

SP10 R02

Use high early strength concrete for all driveways shown in the plans and as directed by the Engineer. Provide high early strength concrete that meets the requirements of Article 1000-5 of the *2018 Standard Specifications*.

Measurement and payment will be in accordance with Section 848 of the *2018 Standard Specifications*.

TEMPORARY SHORING:

(2-20-07) (Rev. 1-16-18)

SP11 R02

Description

Temporary shoring includes cantilever, braced and anchored shoring and temporary mechanically stabilized earth (MSE) walls. Temporary shoring does not include trench boxes. At the Contractor's option, use any type of temporary shoring unless noted otherwise in the plans or as directed. Design and construct temporary shoring based on actual elevations and shoring dimensions in accordance with the contract and accepted submittals. Construct temporary shoring at locations shown in the plans and as directed. Temporary shoring is required to maintain traffic when a 2:1 (H:V) slope from the top of an embankment or bottom of an excavation will intersect the existing ground line less than 5 feet from the edge of pavement of an open travelway. This provision does not apply to pipe, inlet or utility installation unless noted otherwise in the plans.

Positive protection includes concrete barrier and temporary guardrail. Provide positive protection for temporary shoring at locations shown in the plans and as directed. Positive protection is required if temporary shoring is located in the clear zone in accordance with the *AASHTO Roadside Design Guide*.

(A) Cantilever and Braced Shoring

Cantilever shoring consists of steel sheet piles or H-piles with timber lagging. Braced shoring consists of sheet piles or H-piles with timber lagging and bracing such as beams, plates, walers, struts, rakers, etc. Define "piles" as sheet piles or H-piles.

(B) Anchored Shoring

Anchored shoring consists of sheet piles with walers or H-piles with timber lagging anchored with ground or helical anchors. Driven anchors may be accepted at the discretion of the Engineer. A ground anchor consists of a grouted steel bar or multi-strand tendon with an anchorage. A helical anchor consists of a lead section with a central steel shaft and at least one helix steel plate followed by extensions with only central shafts (no helixes) and an anchorage. Anchorages consist of steel bearing plates with washers and hex nuts for bars or steel wedge plates and wedges for strands. Use a prequalified Anchored Wall Contractor to install ground anchors. Define “anchors” as ground, helical or driven anchors.

(C) Temporary MSE Walls

Temporary MSE walls include temporary geosynthetic and wire walls. Define “temporary wall” as a temporary MSE wall and “Temporary Wall Vendor” as the vendor supplying the temporary MSE wall. Define “reinforcement” as geotextile, geogrid, welded wire grid or metallic strip reinforcement.

Temporary geosynthetic walls consist of geotextile or geogrid reinforcement wrapped behind welded wire facing. Define “temporary geotextile wall” as a temporary geosynthetic wall with geotextile reinforcement and “temporary geogrid wall” as a temporary geosynthetic wall with geogrid reinforcement.

Temporary wire walls consist of welded wire grid or metallic strip reinforcement connected to welded wire facing. Define “Wire Wall Vendor” as the vendor supplying the temporary wire wall.

(D) Embedment

Define “embedment” for cantilever, braced and anchored shoring as the pile depth below the grade in front of shoring. Define “embedment” for temporary walls as the wall height below the grade in front of walls.

(E) Positive Protection

Define “unanchored or anchored portable concrete barrier” as portable concrete barrier (PCB) that meets 2018 Roadway Standard Drawing No. 1170.01. Define “concrete barrier” as unanchored or anchored PCB or an approved equal. Define “temporary guardrail” as temporary steel beam guardrail that meets 2018 Roadway Standard Drawing No. 862.02.

Materials

Refer to the *2018 Standard Specifications*.

Item

Concrete Barrier Materials

Section

1170-2

Item	Section
Flowable Fill, Excavatable	1000-6
Geosynthetics	1056
Neat Cement Grout	1003
Portland Cement Concrete	1000
Select Materials	1016
Steel Beam Guardrail Materials	862-2
Steel Plates	1072-2
Steel Sheet Piles and H-Piles	1084
Untreated Timber	1082-2
Welded Wire Reinforcement	1070-3

Provide Type 6 material certifications for shoring materials in accordance with Article 106-3 of the *2018 Standard Specifications*. Use Class IV select material for temporary guardrail. Use neat cement grout for Type 2 grout for ground anchors. Use Class A concrete that meets Article 450-2 of the *2018 Standard Specifications* or Type 1 grout for drilled-in piles. Provide untreated timber with a thickness of at least 3 inches and a bending stress of at least 1,000 pounds per square inch for timber lagging. Provide steel bracing that meets ASTM A36.

(A) Shoring Backfill

Use Class II, Type 1, Class III, Class V or Class VI select material or material that meets AASHTO M 145 for soil classification A-2-4 with a maximum PI of 6 for shoring backfill except do not use A-2-4 soil for backfill around culverts.

(B) Anchors

Store anchor materials on blocking a minimum of 12 inches above the ground and protect it at all times from damage; and when placing in the work make sure it is free from dirt, dust, loose mill scale, loose rust, paint, oil or other foreign materials. Load, transport, unload and store anchor materials so materials are kept clean and free of damage. Bent, damaged or defective materials will be rejected.

(1) Ground Anchors

Use high-strength deformed steel bars that meet AASHTO M 275 or seven-wire strands that meet ASTM A886 or Article 1070-5 of the *2018 Standard Specifications*. Splice bars in accordance with Article 1070-9 of the *2018 Standard Specifications*. Do not splice strands. Use bondbreakers, spacers and centralizers that meet Article 6.3.5 of the *AASHTO LRFD Bridge Construction Specifications*.

(2) Helical Anchors

Use helical anchors with an ICC Evaluation Service, Inc. (ICC-ES) report. Provide couplers, thread bar adapters and bolts recommended by the Anchor Manufacturer to connect helical anchors together and to piles.

(3) Anchorages

Provide steel plates for bearing plates and steel washers, hex nuts, wedge plates and wedges recommended by the Anchor Manufacturer.

(C) Temporary Walls

(1) Welded Wire Facing

Use welded wire reinforcement for welded wire facing, struts and wires. For temporary wire walls, provide welded wire facing supplied by the Wire Wall Vendor or a manufacturer approved or licensed by the vendor. For temporary wire walls with separate reinforcement and facing components, provide connectors (e.g., bars, clamps, plates, etc.) and fasteners (e.g., bolts, nuts, washers, etc.) required by the Wire Wall Vendor.

(2) Geotextiles

Provide Type 2 geotextile for separation and retention geotextiles. Provide Type 5 geotextile for geotextile reinforcement with ultimate tensile strengths in accordance with the accepted submittals.

(3) Geogrid Reinforcement

Use geogrids with a roll width of at least 4 feet and an “approved” or “approved for provisional use” status code. The list of approved geogrids is available from: connect.ncdot.gov/resources/Materials/Pages/Materials-Manual-by-Material.aspx

Provide geogrids for geogrid reinforcement with design strengths in accordance with the accepted submittals. Geogrids are typically approved for ultimate tensile strengths in the machine direction (MD) and cross-machine direction (CD) or short-term design strengths for a 3-year design life in the MD based on material type. Define material type from the website above for shoring backfill as follows:

Material Type	Shoring Backfill
Borrow	A-2-4 Soil
Fine Aggregate	Class II, Type 1 or Class III Select Material
Coarse Aggregate	Class V or VI Select Material

(4) Welded Wire Grid and Metallic Strip Reinforcement

Provide welded wire grid and metallic strip reinforcement supplied by the Wire Wall Vendor or a manufacturer approved or licensed by the vendor. Use welded wire grid reinforcement (“mesh”, “mats” and “ladders”) that meet Article 1070-3 of the *2018 Standard Specifications* and metallic strip reinforcement (“straps”) that meet ASTM A572 or A1011.

Preconstruction Requirements**(A) Concrete Barrier**

Define “clear distance” behind concrete barrier as the horizontal distance between the barrier and edge of pavement. The minimum required clear distance for concrete barrier is shown in the plans. At the Contractor’s option or if the minimum required clear distance is not available, set concrete barrier next to and up against traffic side of temporary shoring except for barrier above temporary walls. Concrete barrier with the minimum required clear distance is required above temporary walls.

(B) Temporary Guardrail

Define “clear distance” behind temporary guardrail as the horizontal distance between guardrail posts and temporary shoring. At the Contractor’s option or if clear distance for cantilever, braced and anchored shoring is less than 4 feet, attach guardrail to traffic side of shoring as shown in the plans. Place ABC in clear distance and around guardrail posts instead of pavement. Do not use temporary guardrail above temporary walls.

(C) Temporary Shoring Designs

Before beginning temporary shoring design, survey existing ground elevations in the vicinity of shoring locations to determine actual design heights (H). Submit PDF files of working drawings and design calculations for temporary shoring designs in accordance with Article 105-2 of the *2018 Standard Specifications*. Submit working drawings showing plan views, shoring profiles, typical sections and details of temporary shoring design and construction sequence. Do not begin shoring construction until a design submittal is accepted.

Have cantilever and braced shoring designed, detailed and sealed by an engineer licensed in the state of North Carolina. Use a prequalified Anchored Wall Design Consultant to design anchored shoring. Provide anchored shoring designs sealed by a Design Engineer approved as a Geotechnical Engineer (key person) for an Anchored Wall Design Consultant. Include details in anchored shoring working drawings of anchor locations and lock-off loads, unit grout/ground bond strengths for ground anchors or minimum installation torque and torsional strength rating for helical anchors and if necessary, obstructions extending through shoring or interfering with anchors. Include details in the anchored shoring construction sequence of pile and anchor installation, excavation and anchor testing.

Provide temporary wall designs sealed by a Design Engineer licensed in the state of North Carolina and employed or contracted by the Temporary Wall Vendor. Include details in temporary wall working drawings of geotextile and reinforcement types, locations and directions and obstructions extending through walls or interfering with reinforcement.

(1) Soil Parameters

Design temporary shoring for the assumed soil parameters and groundwater elevations shown in the plans. Assume the following soil parameters for shoring backfill:

(a) Unit weight (γ) = 120 pcf;

(b)	Friction Angle (ϕ)	Shoring Backfill
	30°	A-2-4 Soil
	34°	Class II, Type 1 or Class III Select Material
	38°	Class V or VI Select Material

(c) Cohesion (c) = 0 psf.

(2) Traffic Surcharge

Design temporary shoring for a traffic surcharge of 250 pounds per square foot if traffic will be above and within H of shoring. This traffic surcharge does not apply to construction traffic. Design temporary shoring for any construction surcharge if construction traffic will be above and within H of shoring. For LRFD shoring designs, apply traffic (live load) surcharge in accordance with Figure C11.5.5-3 of the *AASHTO LRFD Bridge Design Specifications*.

(3) Cantilever, Braced and Anchored Shoring Designs

Use shoring backfill for fill sections and voids between cantilever, braced and anchored shoring and the critical failure surface. Use concrete or grout for embedded portions of drilled-in H-piles. Do not use drilled-in sheet piles.

Define “top of shoring” for cantilever, braced and anchored shoring as where the grade intersects the back of sheet piles or H-piles and timber lagging. Design cantilever, braced and anchored shoring for a traffic impact load of 2,000 pounds per foot applied 18 inches above top of shoring if concrete barrier is above and next to shoring or temporary guardrail is above and attached to shoring. For anchored shoring designs, apply traffic impact load as horizontal load (P_{HI}) in accordance with Figure 3.11.6.3-2(a) of the *AASHTO LRFD specifications*.

Extend cantilever, braced and anchored shoring at least 32 inches above top of shoring if shoring is designed for traffic impact. Otherwise, extend shoring at least 6 inches above top of shoring.

Design cantilever, braced and anchored shoring for a maximum deflection of 3 inches if the horizontal distance to the closest edge of pavement or structure is less than H. Otherwise, design shoring for a maximum deflection of 6 inches. Design cantilever and braced shoring in accordance with the plans and *AASHTO Guide Design Specifications for Bridge Temporary Works*.

Design anchored shoring in accordance with the plans and Article 11.9 of the *AASHTO LRFD Bridge Design Specifications*. Use a resistance factor of 0.80 for

tensile resistance of anchors with bars, strands or shafts. Extend the unbonded length for ground anchors and the shallowest helix for helical anchors at least 5 feet behind the critical failure surface. Do not extend anchors beyond right-of-way or easement limits. If existing or future obstructions such as foundations, guardrail posts, pavements, pipes, inlets or utilities will interfere with anchors, maintain a clearance of at least 6 inches between obstructions and anchors.

(4) Temporary Wall Designs

Use shoring backfill in the reinforced zone of temporary walls. Separation geotextiles are required between shoring backfill and backfill, natural ground or culverts along the sides of the reinforced zone perpendicular to the wall face. For Class V or VI select material in the reinforced zone, separation geotextiles are also required between shoring backfill and backfill or natural ground on top of and at the back of the reinforced zone.

Design temporary walls in accordance with the plans and Article 11.10 of the *AASHTO LRFD Bridge Design Specifications*. Embed temporary walls at least 18 inches except for walls on structures or rock as determined by the Engineer. Use a uniform reinforcement length throughout the wall height of at least 0.7H or 6 feet, whichever is longer. Extend the reinforced zone at least 6 inches beyond end of reinforcement. Do not locate the reinforced zone outside right-of-way or easement limits.

Use the simplified method for determining maximum reinforcement loads in accordance with the AASHTO LRFD specifications. For geotextile reinforcement, use geotextile properties approved by the Department or default values in accordance with the AASHTO LRFD specifications. For geogrid reinforcement, use approved geogrid properties available from the website shown elsewhere in this provision. If the website does not list a short-term design strength for an approved geogrid, use a short-term design strength equal to the ultimate tensile strength divided by 3.5 for the geogrid reinforcement. Use geosynthetic properties for the direction reinforcement will be installed, a 3-year design life and shoring backfill to be used in the reinforced zone.

Do not use more than 4 different reinforcement strengths for each temporary geosynthetic wall. Design temporary geotextile walls for a reinforcement coverage ratio (R_c) of 1.0. For temporary geogrid walls with an R_c of less than 1.0, use a maximum horizontal clearance between geogrids of 3 feet and stagger reinforcement so geogrids are centered over gaps in the reinforcement layer below.

For temporary geosynthetic walls, use “L” shaped welded wire facing with 18 to 24 inch long legs. Locate geotextile or geogrid reinforcement so reinforcement layers are at the same level as the horizontal legs of welded wire facing. Use vertical reinforcement spacing equal to facing height. Wrap geotextile or geogrid reinforcement behind welded wire facing and extend reinforcement at least 3 feet back behind facing into shoring backfill.

For temporary wire walls with separate reinforcement and facing components, attach welded wire grid or metallic strip reinforcement to welded wire facing with a connection approved by the Department. For temporary geogrid and wire walls, retain shoring backfill at welded wire facing with retention geotextiles and extend geotextiles at least 3 feet back behind facing into backfill.

(D) Preconstruction Meeting

The Engineer may require a shoring preconstruction meeting to discuss the construction, inspection and testing of the temporary shoring. If required and if this meeting occurs before all shoring submittals have been accepted, additional preconstruction meetings may be required before beginning construction of temporary shoring without accepted submittals. The Resident, District or Bridge Maintenance Engineer, Area Construction Engineer, Geotechnical Operations Engineer, Contractor and Shoring Contractor Superintendent will attend preconstruction meetings.

Construction Methods

Control drainage during construction in the vicinity of shoring. Direct run off away from shoring and shoring backfill. Contain and maintain backfill and protect material from erosion.

Install positive protection in accordance with the contract and accepted submittals. Use PCB in accordance with Section 1170 of the *2018 Standard Specifications* and 2018 Roadway Standard Drawing No. 1170.01. Use temporary guardrail in accordance with Section 862 of the *2018 Standard Specifications* and 2018 Roadway Standard Drawing Nos. 862.01, 862.02 and 862.03.

(A) Tolerances

Construct shoring with the following tolerances:

- (1) Horizontal wires of welded wire facing are level in all directions,
- (2) Shoring location is within 6 inches of horizontal and vertical alignment shown in the accepted submittals, and
- (3) Shoring plumbness (batter) is not negative and within 2 degrees of vertical.

(B) Cantilever, Braced and Anchored Shoring Installation

If overexcavation behind cantilever, braced or anchored shoring is shown in the accepted submittals, excavate before installing piles. Otherwise, install piles before excavating for shoring. Install cantilever, braced or anchored shoring in accordance with the construction sequence shown in the accepted submittals. Remove piles and if applicable, timber lagging when shoring is no longer needed.

(1) Pile Installation

Install piles with the minimum required embedment and extension in accordance with Subarticles 450-3(D) and 450-3(E) of the *2018 Standard Specifications* except that a pile driving equipment data form is not required. Piles may be installed with a vibratory hammer as approved by the Engineer.

Do not splice sheet piles. Use pile excavation to install drilled-in H-piles. After filling holes with concrete or grout to the elevations shown in the accepted submittals, remove any fluids and fill remaining portions of holes with flowable fill. Cure concrete or grout at least 7 days before excavating.

Notify the Engineer if refusal is reached before pile excavation or driven piles attain the minimum required embedment. When this occurs, a revised design submittal may be required.

(2) Excavation

Excavate in front of piles from the top down in accordance with the accepted submittals. For H-piles with timber lagging and braced and anchored shoring, excavate in staged horizontal lifts with a maximum height of 5 feet. Remove flowable fill and material in between H-piles as needed to install timber lagging. Position lagging with at least 3 inches of contact in the horizontal direction between the lagging and pile flanges. Do not excavate the next lift until timber lagging for the current lift is installed and if applicable, bracing and anchors for the current lift are accepted. Backfill behind cantilever, braced or anchored shoring with shoring backfill.

(3) Anchor Installation

If applicable, install foundations located behind anchored shoring before installing anchors. Fabricate and install ground anchors in accordance with the accepted submittals, Articles 6.4 and 6.5 of the *AASHTO LRFD Bridge Construction Specifications* and the following unless otherwise approved:

- (a) Materials in accordance with this provision are required instead of materials conforming to Articles 6.4 and 6.5.3 of the AASHTO LRFD Specifications,
- (b) Encapsulation-protected ground anchors in accordance with Article 6.4.1.2 of the AASHTO LRFD specifications are not required, and
- (c) Corrosion protection for unbonded lengths of ground anchors and anchorage covers are not required.
- (d) Measure grout temperature, density and flow during grouting with at least the same frequency grout cubes are made for compressive strength. Perform density and flow field tests in the presence of the Engineer in accordance with American National Standards Institute/American

Petroleum Institute Recommended Practice 13B-1 (Section 4, Mud Balance) and ASTM C939 (Flow Cone), respectively.

Install helical anchors in accordance with the accepted submittals and Anchor Manufacturer's instructions. Measure torque during installation and do not exceed the torsional strength rating of the helical anchor. Attain the minimum required installation torque and penetration before terminating anchor installation. When replacing a helical anchor, embed last helix of the replacement anchor at least 3 helix plate diameters past the location of the first helix of the previous anchor.

(4) Anchor Testing

Proof test and lock-off anchors in accordance with the accepted submittals and Article 6.5.5 of the *AASHTO LRFD Bridge Construction Specifications* except for the acceptance criteria in Article 6.5.5.5. For the AASHTO LRFD specifications, "ground anchor" refers to a ground or helical anchor and "tendon" refers to a bar, strand or shaft.

(a) Anchor Acceptance

Anchor acceptance is based in part on the following criteria.

- (i) For ground and helical anchors, total movement is less than 0.04 inches between the 1 and 10 minute readings or less than 0.08 inches between the 6 and 60 minute readings.
- (ii) For ground anchors, total movement at maximum test load exceeds 80% of the theoretical elastic elongation of the unbonded length.

(b) Anchor Test Results

Submit PDF files of anchor test records including movement versus load plots for each load increment within 24 hours of completing each row of anchors. The Engineer will review the test records to determine if the anchors are acceptable.

If the Engineer determines an anchor is unacceptable, revise the anchor design or installation methods. Submit a revised anchored shoring design for acceptance and provide an acceptable anchor with the revised design or installation methods. If required, replace the anchor or provide additional anchors with the revised design or installation methods.

(C) Temporary Wall Installation

Excavate as necessary for temporary walls in accordance with the plans and accepted submittals. If applicable, install foundations located in the reinforced zone before placing shoring backfill or reinforcement unless otherwise approved. Notify the Engineer when foundation excavation is complete. Do not place shoring backfill or reinforcement until excavation dimensions and foundation material are approved.

Erect welded wire facing so the wall position is as shown in the plans and accepted submittals. Set welded wire facing adjacent to each other in the horizontal and vertical direction to completely cover the wall face with facing. Stagger welded wire facing to create a running bond by centering facing over joints in the row below.

Wrap geotextile reinforcement and retention geotextiles behind welded wire facing as shown in the plans and accepted submittals and cover geotextiles with at least 3" of shoring backfill. Overlap adjacent geotextile reinforcement and retention and separation geotextiles at least 18 inches with seams oriented perpendicular to the wall face. Hold geotextiles in place with wire staples or anchor pins as needed.

Place reinforcement within 3 inches of locations shown in the plans and accepted submittals. Before placing shoring backfill, pull reinforcement taut so it is in tension and free of kinks, folds, wrinkles or creases. Install reinforcement with the direction shown in the plans and accepted submittals. For temporary wire walls with separate reinforcement and facing components, attach welded wire grid or metallic strip reinforcement to welded wire facing as shown in the accepted submittals. Do not splice or overlap reinforcement so seams are parallel to the wall face. Contact the Engineer when unanticipated existing or future obstructions such as foundations, pavements, pipes, inlets or utilities will interfere with reinforcement.

Place shoring backfill in the reinforced zone in 8 to 10 inch thick lifts. Compact A-2-4 soil and Class II, Type 1 and Class III select material in accordance with Subarticle 235-3(C) of the *2018 Standard Specifications*. Use only hand operated compaction equipment to compact backfill within 3 feet of welded wire facing. At a distance greater than 3 feet, compact shoring backfill with at least 4 passes of an 8 to 10 ton vibratory roller in a direction parallel to the wall face. Smooth wheeled or rubber tired rollers are also acceptable for compacting backfill. Do not use sheepsfoot, grid rollers or other types of compaction equipment with feet. Do not displace or damage reinforcement when placing and compacting shoring backfill. End dumping directly on geotextile or geogrid reinforcement is not permitted. Do not operate heavy equipment on reinforcement until it is covered with at least 8 inches of shoring backfill. Replace any damaged reinforcement to the satisfaction of the Engineer.

Backfill for temporary walls outside the reinforced zone in accordance with Article 410-8 of the *2018 Standard Specifications*. Bench temporary walls into the sides of excavations where applicable. For temporary geosynthetic walls with top of wall within 5 feet of finished grade, remove top facing and incorporate top reinforcement layer into fill when placing fill in front of wall. Temporary walls remain in place permanently unless otherwise required.

Measurement and Payment

Temporary Shoring will be measured and paid in square feet. Temporary walls will be measured as the square feet of exposed wall face area. Cantilever, braced or anchored shoring will be measured as the square feet of exposed shoring face area with the shoring height equal to the difference between the top and bottom of shoring elevations. Define “top of shoring” as where the grade intersects the back of sheet piles or H-piles and timber lagging. Define “bottom of shoring” as where the grade intersects front of sheet piles or H-piles and timber lagging. No measurement will be made for any embedment, shoring extension above top of shoring or pavement thickness above temporary walls.

The contract unit price for *Temporary Shoring* will be full compensation for providing shoring designs, submittals and materials, excavating, backfilling, hauling and removing excavated materials and supplying all labor, tools, equipment and incidentals necessary to construct temporary shoring.

No payment will be made for temporary shoring not shown in the plans or required by the Engineer including shoring for OSHA reasons or the Contractor’s convenience. No value engineering proposals will be accepted based solely on revising or eliminating shoring locations shown in the plans or estimated quantities shown in the bid item sheets as a result of actual field measurements or site conditions.

PCB will be measured and paid in accordance with Section 1170 of the *2018 Standard Specifications*. No additional payment will be made for anchoring PCB for temporary shoring. Costs for anchoring PCB will be incidental to temporary shoring.

Temporary guardrail will be measured and paid for in accordance with Section 862 of the *2018 Standard Specifications*.

Payment will be made under:

Pay Item

Temporary Shoring

Pay Unit

Square Foot

PERMANENT SEEDING AND MULCHING:

(7-1-95)

1660

SP16 R02

The Department desires that permanent seeding and mulching be established on this project as soon as practical after slopes or portions of slopes have been graded. As an incentive to obtain an early stand of vegetation on this project, the Contractor's attention is called to the following:

For all permanent seeding and mulching that is satisfactorily completed in accordance with the requirements of Section 1660 in the *2018 Standard Specifications* and within the following percentages of elapsed contract times, an additional payment will be made to the Contractor as an incentive additive. The incentive additive will be determined by multiplying the number of acres of seeding and mulching satisfactorily completed times the contract unit bid price per acre for Seeding and Mulching times the appropriate percentage additive.

Percentage of Elapsed Contract Time	Percentage Additive
0% - 30%	30%
30.01% - 50%	15%

Percentage of elapsed contract time is defined as the number of calendar days from the date of availability of the contract to the date the permanent seeding and mulching is acceptably completed divided by the total original contract time.

STANDARD SPECIAL PROVISION
AVAILABILITY OF FUNDS – TERMINATION OF CONTRACTS

(5-20-08)

Z-2

General Statute 143C-6-11. (h) Highway Appropriation is hereby incorporated verbatim in this contract as follows:

(h) Amounts Encumbered. – Transportation project appropriations may be encumbered in the amount of allotments made to the Department of Transportation by the Director for the estimated payments for transportation project contract work to be performed in the appropriation fiscal year. The allotments shall be multiyear allotments and shall be based on estimated revenues and shall be subject to the maximum contract authority contained in *General Statute 143C-6-11(c)*. Payment for transportation project work performed pursuant to contract in any fiscal year other than the current fiscal year is subject to appropriations by the General Assembly. Transportation project contracts shall contain a schedule of estimated completion progress, and any acceleration of this progress shall be subject to the approval of the Department of Transportation provided funds are available. The State reserves the right to terminate or suspend any transportation project contract, and any transportation project contract shall be so terminated or suspended if funds will not be available for payment of the work to be performed during that fiscal year pursuant to the contract. In the event of termination of any contract, the contractor shall be given a written notice of termination at least 60 days before completion of scheduled work for which funds are available. In the event of termination, the contractor shall be paid for the work already performed in accordance with the contract specifications.

Payment will be made on any contract terminated pursuant to the special provision in accordance with Subarticle 108-13(D) of the *2018 Standard Specifications*.

STANDARD SPECIAL PROVISION
NCDOT GENERAL SEED SPECIFICATION FOR SEED QUALITY

(5-17-11)

Z-3

Seed shall be sampled and tested by the North Carolina Department of Agriculture and Consumer Services, Seed Testing Laboratory. When said samples are collected, the vendor shall supply an independent laboratory report for each lot to be tested. Results from seed so sampled shall be final. Seed not meeting the specifications shall be rejected by the Department of Transportation and shall not be delivered to North Carolina Department of Transportation warehouses. If seed has been delivered it shall be available for pickup and replacement at the supplier's expense.

Any re-labeling required by the North Carolina Department of Agriculture and Consumer Services, Seed Testing Laboratory, that would cause the label to reflect as otherwise specified herein shall be rejected by the North Carolina Department of Transportation.

Seed shall be free from seeds of the noxious weeds Johnsongrass, Balloonvine, Jimsonweed, Witchweed, Itchgrass, Serrated Tussock, Showy Crotalaria, Smooth Crotalaria, Sicklepod, Sandbur, Wild Onion, and Wild Garlic. Seed shall not be labeled with the above weed species on the seed analysis label. Tolerances as applied by the Association of Official Seed Analysts will NOT be allowed for the above noxious weeds except for Wild Onion and Wild Garlic.

Tolerances established by the Association of Official Seed Analysts will generally be recognized. However, for the purpose of figuring pure live seed, the found pure seed and found germination percentages as reported by the North Carolina Department of Agriculture and Consumer Services, Seed Testing Laboratory will be used. Allowances, as established by the NCDOT, will be recognized for minimum pure live seed as listed on the following pages.

The specifications for restricted noxious weed seed refers to the number per pound as follows:

<u>Restricted Noxious Weed</u>	<u>Limitations per Lb. Of Seed</u>	<u>Restricted Noxious Weed</u>	<u>Limitations per Lb. of Seed</u>
Blessed Thistle	4 seeds	Cornflower (Ragged Robin)	27 seeds
Cocklebur	4 seeds	Texas Panicum	27 seeds
Spurred Anoda	4 seeds	Bracted Plantain	54 seeds
Velvetleaf	4 seeds	Buckhorn Plantain	54 seeds
Morning-glory	8 seeds	Broadleaf Dock	54 seeds
Corn Cockle	10 seeds	Curly Dock	54 seeds
Wild Radish	12 seeds	Dodder	54 seeds
Purple Nutsedge	27 seeds	Giant Foxtail	54 seeds
Yellow Nutsedge	27 seeds	Horsenettle	54 seeds
Canada Thistle	27 seeds	Quackgrass	54 seeds
Field Bindweed	27 seeds	Wild Mustard	54 seeds
Hedge Bindweed	27 seeds		

Seed of Pensacola Bahiagrass shall not contain more than 7% inert matter, Kentucky Bluegrass, Centipede and Fine or Hard Fescue shall not contain more than 5% inert matter whereas a maximum of 2% inert matter will be allowed on all other kinds of seed. In addition, all seed shall

not contain more than 2% other crop seed nor more than 1% total weed seed. The germination rate as tested by the North Carolina Department of Agriculture shall not fall below 70%, which includes both dormant and hard seed. Seed shall be labeled with not more than 7%, 5% or 2% inert matter (according to above specifications), 2% other crop seed and 1% total weed seed.

Exceptions may be made for minimum pure live seed allowances when cases of seed variety shortages are verified. Pure live seed percentages will be applied in a verified shortage situation. Those purchase orders of deficient seed lots will be credited with the percentage that the seed is deficient.

FURTHER SPECIFICATIONS FOR EACH SEED GROUP ARE GIVEN BELOW:

Minimum 85% pure live seed; maximum 1% total weed seed; maximum 2% total other crop seed; maximum 144 restricted noxious weed seed per pound. Seed less than 83% pure live seed will not be approved.

Sericea Lespedeza
Oats (seeds)

Minimum 80% pure live seed; maximum 1% total weed seed; maximum 2% total other crop; maximum 144 restricted noxious weed seed per pound. Seed less than 78% pure live seed will not be approved.

Tall Fescue (all approved varieties)	Bermudagrass
Kobe Lespedeza	Browntop Millet
Korean Lespedeza	German Millet – Strain R
Weeping Lovegrass	Clover – Red/White/Crimson
Carpetgrass	

Minimum 78% pure live seed; maximum 1% total weed seed; maximum 2% total other crop seed; maximum 144 restricted noxious weed seed per pound. Seed less than 76% pure live seed will not be approved.

Common or Sweet Sundangrass

Minimum 76% pure live seed; maximum 1% total weed seed; maximum 2% total other crop seed; maximum 144 restricted noxious weed seed per pound. Seed less than 74% pure live seed will not be approved.

Rye (grain; all varieties)
Kentucky Bluegrass (all approved varieties)
Hard Fescue (all approved varieties)
Shrub (bicolor) Lespedeza

Minimum 70% pure live seed; maximum 1% total weed seed; maximum 2% total other crop seed; maximum 144 noxious weed seed per pound. Seed less than 70% pure live seed will not be approved.

Centipedegrass	Japanese Millet
Crownvetch	Reed Canary Grass
Pensacola Bahiagrass	Zoysia
Creeping Red Fescue	

Minimum 70% pure live seed; maximum 1% total weed seed; maximum 2% total other crop seed; maximum 5% inert matter; maximum 144 restricted noxious weed seed per pound.

Barnyard Grass
Big Bluestem
Little Bluestem
Bristly Locust
Birdsfoot Trefoil
Indiangrass
Orchardgrass
Switchgrass
Yellow Blossom Sweet Clover

STANDARD SPECIAL PROVISION

ERRATA

(2-12-18)

Z-4

Revise the *2018 Standard Specifications* as follows:

Division 7

Page 7-27, line 4, Article 725-1 MEASUREMENT AND PAYMENT, replace article number “725-1” with “724-4”.

Page 7-28, line 10, Article 725-1 MEASUREMENT AND PAYMENT, replace article number “725-1” with “725-3”.

Division 8

Page 8-23, lines 3, 6, 11 and 13, Section 836, SLUICE GATE, replace article number “8366” with “836”.

Division 10

Page 10-69, Table 1046-1 WIRE DIAMETER, rename RECYCLED PLASTIC AND COMPOSITE OFFSET BLOCK PROPERTIES

Page 10-162, line 1, Article 1080-50 PAINT FOR VERTICAL MARKERS, replace article number “1080-50” with “1080-10”.

Page 10-162, line 5, Article 1080-61 EPOXY RESIN FOR REINFORCING STEEL, replace article number “1080-61” with “1080-11”.

Page 10-162, line 22, Article 1080-72 ABRASIVE MATERIALS FOR BLAST CLEANING STEEL, replace article number “1080-72” with “1080-12”.

Page 10-163, line 25, Article 1080-83 FIELD PERFORMANCE AND SERVICES, replace article number “1080-83” with “1080-13”.

STANDARD SPECIAL PROVISION**PLANT AND PEST QUARANTINES****(Imported Fire Ant, Gypsy Moth, Witchweed, Emerald Ash Borer, And Other Noxious Weeds)**

(3-18-03) (Rev. 12-20-16)

Z-04a

Within Quarantined Area

This project may be within a county regulated for plant and/or pests. If the project or any part of the Contractor's operations is located within a quarantined area, thoroughly clean all equipment prior to moving out of the quarantined area. Comply with federal/state regulations by obtaining a certificate or limited permit for any regulated article moving from the quarantined area.

Originating in a Quarantined County

Obtain a certificate or limited permit issued by the N.C. Department of Agriculture/United States Department of Agriculture. Have the certificate or limited permit accompany the article when it arrives at the project site.

Contact

Contact the N.C. Department of Agriculture/United States Department of Agriculture at 1-800-206-9333, 919-707-3730, or <http://www.ncagr.gov/plantindustry/> to determine those specific project sites located in the quarantined area or for any regulated article used on this project originating in a quarantined county.

Regulated Articles Include

1. Soil, sand, gravel, compost, peat, humus, muck, and decomposed manure, separately or with other articles. This includes movement of articles listed above that may be associated with cut/waste, ditch pulling, and shoulder cutting.
2. Plants with roots including grass sod.
3. Plant crowns and roots.
4. Bulbs, corms, rhizomes, and tubers of ornamental plants.
5. Hay, straw, fodder, and plant litter of any kind.
6. Clearing and grubbing debris.
7. Used agricultural cultivating and harvesting equipment.
8. Used earth-moving equipment.
9. Any other products, articles, or means of conveyance, of any character, if determined by an inspector to present a hazard of spreading imported fire ant, gypsy moth, witchweed, emerald ash borer, or other noxious weeds.

STANDARD SPECIAL PROVISION

MINIMUM WAGES

(7-21-09)

Z-5

FEDERAL: The Fair Labor Standards Act provides that with certain exceptions every employer shall pay wages at the rate of not less than SEVEN DOLLARS AND TWENTY FIVE CENTS (\$7.25) per hour.

STATE: The North Carolina Minimum Wage Act provides that every employer shall pay to each of his employees, wages at a rate of not less than SEVEN DOLLARS AND TWENTY FIVE CENTS (\$7.25) per hour.

The minimum wage paid to all skilled labor employed on this contract shall be SEVEN DOLLARS AND TWENTY FIVE CENTS (\$7.25) per hour.

The minimum wage paid to all intermediate labor employed on this contract shall be SEVEN DOLLARS AND TWENTY FIVE CENTS (\$7.25) per hour.

The minimum wage paid to all unskilled labor on this contract shall be SEVEN DOLLARS AND TWENTY FIVE CENTS (\$7.25) per hour.

This determination of the intent of the application of this act to the contract on this project is the responsibility of the Contractor.

The Contractor shall have no claim against the Department of Transportation for any changes in the minimum wage laws, Federal or State. It is the responsibility of the Contractor to keep fully informed of all Federal and State Laws affecting his contract.

STANDARD SPECIAL PROVISION**TITLE VI AND NONDISCRIMINATION:**

(6-28-77)(Rev 6/19/2018)

Z-6

Revise the *2018 Standard Specifications* as follows:

Replace Article 103-4(B) with the following:

The North Carolina Department of Transportation is committed to carrying out the U.S. Department of Transportation's policy of ensuring nondiscrimination in the award and administration of contracts.

The provisions of this section related to United States Department of Transportation (US DOT) Order 1050.2A, Title 49 Code of Federal Regulations (CFR) part 21, 23 United States Code (U.S.C.) 140 and 23 CFR part 200 (or 49 CFR 303, 49 U.S.C. 5332 or 49 U.S.C. 47123) are applicable to all North Carolina Department of Transportation (NCDOT) contracts and to all related subcontracts, material supply, engineering, architectural and other service contracts, regardless of dollar amount. Any Federal provision that is specifically required not specifically set forth is hereby incorporated by reference.

(1) **Title VI Assurances (USDOT Order 1050.2A, Appendix A)**

During the performance of this contract, the contractor, for itself, its assignees, and successors in interest (hereinafter referred to as the "contractor") agrees as follows:

(a) Compliance with Regulations

The contractor (hereinafter includes consultants) shall comply with the Acts and the Regulations relative to Nondiscrimination in Federally-assisted programs of the U.S. Department of Transportation, Federal Highway Administration (FHWA), as they may be amended from time to time, which are herein incorporated by reference and made a part of this contract.

(b) Nondiscrimination

The contractor, with regard to the work performed by it during the contract, shall not discriminate on the grounds of race, color, or national origin in the selection and retention of subcontractors, including procurements of materials and leases of equipment. The contractor shall not participate directly or indirectly in the discrimination prohibited by the Acts and the Regulations, including employment practices when the contract covers any activity, project, or program set forth in Appendix B of 49 CFR Part 21.

(c) Solicitations for Subcontractors, Including Procurements of Materials and Equipment

In all solicitations, either by competitive bidding, or negotiation made by the contractor for work to be performed under a subcontract, including procurements of materials, or leases of equipment, each potential subcontractor or supplier shall be notified by the contractor of the contractor's obligations under this contract and the Acts and the Regulations relative to Nondiscrimination on the grounds of race, color, or national origin.

(d) Information and Reports

The contractor shall provide all information and reports required by the Acts, the Regulations, and directives issued pursuant thereto and shall permit access to its books, records, accounts, other sources of information, and its facilities as may be determined by the Recipient or the FHWA to be pertinent to ascertain compliance with such Acts,

Regulations, and instructions. Where any information required of a contractor is in the exclusive possession of another who fails or refuses to furnish the information, the contractor shall so certify to the Recipient or the FHWA, as appropriate, and shall set forth what efforts it has made to obtain the information.

(e) Sanctions for Noncompliance:

In the event of a contractor's noncompliance with the Non-discrimination provisions of this contract, the Recipient will impose such contract sanctions as it and/or the FHWA may determine to be appropriate, including, but not limited to:

- (i) Withholding payments to the contractor under the contract until the contractor complies; and/or
- (ii) Cancelling, terminating, or suspending a contract, in whole or in part.

(f) Incorporation of Provisions

The contractor shall include the provisions of paragraphs (a) through (f) in every subcontract, including procurements of materials and leases of equipment, unless exempt by the Acts, the Regulations and directives issued pursuant thereto. The contractor shall take action with respect to any subcontract or procurement as the Recipient or the FHWA may direct as a means of enforcing such provisions including sanctions for noncompliance. Provided, that if the contractor becomes involved in, or is threatened with litigation by a subcontractor, or supplier because of such direction, the contractor may request the Recipient to enter into any litigation to protect the interests of the Recipient. In addition, the contractor may request the United States to enter into the litigation to protect the interests of the United States.

(2) **Title VI Nondiscrimination Program (23 CFR 200.5(p))**

The North Carolina Department of Transportation (NCDOT) has assured the USDOT that, as a condition to receiving federal financial assistance, NCDOT will comply with Title VI of the Civil Rights Act of 1964 and all requirements imposed by Title 49 CFR part 21 and related nondiscrimination authorities to ensure that no person shall, on the ground of race, color, national origin, limited English proficiency, sex, age, or disability (including religion/creed or income-level, where applicable), be excluded from participation in, be denied the benefits of, or be subjected to discrimination under any programs, activities, or services conducted or funded by NCDOT. Contractors and other organizations under contract or agreement with NCDOT must also comply with Title VI and related authorities, therefore:

(a) During the performance of this contract or agreement, contractors (e.g., subcontractors, consultants, vendors, prime contractors) are responsible for complying with NCDOT's Title VI Program. Contractors are not required to prepare or submit Title VI Programs. To comply with this section, the prime contractor shall:

1. Post NCDOT's Notice of Nondiscrimination and the Contractor's own Equal Employment Opportunity (EEO) Policy in conspicuous locations accessible to all employees, applicants and subcontractors on the jobsite.
2. Physically incorporate the required Title VI clauses into all subcontracts on federally-assisted and state-funded NCDOT projects, and ensure inclusion by subcontractors into all lower-tier subcontracts.
3. Required Solicitation Language. The Contractor shall include the following notification in all solicitations for bids and requests for work or material, regardless of funding source:

“The North Carolina Department of Transportation, in accordance with the provisions of Title VI of the Civil Rights Act of 1964 (78 Stat. 252, 42 U.S.C. §§

2000d to 2000d-4) and the Regulations, hereby notifies all bidders that it will affirmatively ensure that any contract entered into pursuant to this advertisement, disadvantaged business enterprises will be afforded full and fair opportunity to submit bids in response to this invitation and will not be discriminated against on the grounds of race, color, or national origin in consideration for an award. In accordance with other related nondiscrimination authorities, bidders and contractors will also not be discriminated against on the grounds of sex, age, disability, low-income level, creed/religion, or limited English proficiency in consideration for an award.”

4. Physically incorporate the FHWA-1273, in its entirety, into all subcontracts and subsequent lower tier subcontracts on Federal-aid highway construction contracts only.
 5. Provide language assistance services (i.e., written translation and oral interpretation), free of charge, to LEP employees and applicants. Contact NCDOT OCR for further assistance, if needed.
 6. For assistance with these Title VI requirements, contact the NCDOT Title VI Nondiscrimination Program at 1-800-522-0453.
- (b) Subrecipients (e.g. cities, counties, LGAs, planning organizations) may be required to prepare and submit a Title VI Plan to NCDOT, including Title VI Assurances and/or agreements. Subrecipients must also ensure compliance by their contractors and subrecipients with Title VI. (23 CFR 200.9(b)(7))
- (c) If reviewed or investigated by NCDOT, the contractor or subrecipient agrees to take affirmative action to correct any deficiencies found within a reasonable time period, not to exceed 90 calendar days, unless additional time is granted by NCDOT. (23 CFR 200.9(b)(15))
- (d) The Contractor is responsible for notifying subcontractors of NCDOT’s External Discrimination Complaints Process.
1. **Applicability**

Title VI and related laws protect participants and beneficiaries (e.g., members of the public and contractors) from discrimination by NCDOT employees, subrecipients and contractors, regardless of funding source.
 2. **Eligibility**

Any person—or class of persons—who believes he/she has been subjected to discrimination based on race, color, national origin, Limited English Proficiency (LEP), sex, age, or disability (and religion in the context of employment, aviation, or transit) may file a written complaint. The law also prohibits intimidation or retaliation of any sort.
 3. **Time Limits and Filing Options**

Complaints may be filed by the affected individual(s) or a representative and must be filed no later than 180 calendar days after the following:

 - (i) The date of the alleged act of discrimination; or
 - (ii) The date when the person(s) became aware of the alleged discrimination; or
 - (iii) Where there has been a continuing course of conduct, the date on which that conduct was discontinued or the latest instance of the conduct.

Title VI and related discrimination complaints may be submitted to the following entities:

- North Carolina Department of Transportation, Office of Civil Rights, Title VI Program, 1511 Mail Service Center, Raleigh, NC 27699-1511; toll free 1-800-522-0453
 - Federal Highway Administration, North Carolina Division Office, 310 New Bern Avenue, Suite 410, Raleigh, NC 27601, 919-747-7010
 - US Department of Transportation, Departmental Office of Civil Rights, External Civil Rights Programs Division, 1200 New Jersey Avenue, SE, Washington, DC 20590; 202-366-4070
4. Format for Complaints
Complaints must be in writing and signed by the complainant(s) or a representative, and include the complainant's name, address, and telephone number. Complaints received by fax or e-mail will be acknowledged and processed. Allegations received by telephone will be reduced to writing and provided to the complainant for confirmation or revision before processing. Complaints will be accepted in other languages, including Braille.
5. Discrimination Complaint Form
Contact NCDOT Civil Rights to receive a full copy of the Discrimination Complaint Form and procedures.
6. Complaint Basis
Allegations must be based on issues involving race, color, national origin (LEP), sex, age, disability, or religion (in the context of employment, aviation or transit). "Basis" refers to the complainant's membership in a protected group category.

**TABLE 103-1
COMPLAINT BASIS**

Protected Categories	Definition	Examples	Applicable Nondiscrimination Authorities
Race and Ethnicity	An individual belonging to one of the accepted racial groups; or the perception, based usually on physical characteristics that a person is a member of a racial group	Black/African American, Hispanic/Latino, Asian, American Indian/Alaska Native, Native Hawaiian/Pacific Islander, White	Title VI of the Civil Rights Act of 1964; 49 CFR Part 21; 23 CFR 200; 49 U.S.C. 5332(b); 49 U.S.C. 47123. (<i>Executive Order 13166</i>)
Color	Color of skin, including shade of skin within a racial group	Black, White, brown, yellow, etc.	
National Origin (<i>Limited English Proficiency</i>)	Place of birth. Citizenship is not a factor. (<i>Discrimination based on language or a person's accent is also covered</i>)	Mexican, Cuban, Japanese, Vietnamese, Chinese	
Sex	Gender. The sex of an individual. <i>Note: Sex under this program does not include sexual orientation.</i>	Women and Men	1973 Federal-Aid Highway Act; 49 U.S.C. 5332(b); 49 U.S.C. 47123.
Age	Persons of any age	21-year-old person	Age Discrimination Act of 1975 49 U.S.C. 5332(b); 49 U.S.C. 47123.
Disability	Physical or mental impairment, permanent or temporary, or perceived.	Blind, alcoholic, para-amputee, epileptic, diabetic, arthritic	Section 504 of the Rehabilitation Act of 1973; Americans with Disabilities Act of 1990

<p>Religion (in the context of employment) <i>(Religion/ Creed in all aspects of any aviation or transit-related construction)</i></p>	<p>An individual belonging to a religious group; or the perception, based on distinguishable characteristics that a person is a member of a religious group. In practice, actions taken as a result of the moral and ethical beliefs as to what is right and wrong, which are sincerely held with the strength of traditional religious views. Note: Does not have to be associated with a recognized religious group or church; if an individual sincerely holds to the belief, it is a protected religious practice.</p>	<p>Muslim, Christian, Sikh, Hindu, etc.</p>	<p>Title VII of the Civil Rights Act of 1964; 23 CFR 230; FHWA-1273 Required Contract Provisions. (49 U.S.C. 5332(b); 49 U.S.C. 47123)</p>
--	---	---	--

(3) Pertinent Nondiscrimination Authorities

During the performance of this contract, the contractor, for itself, its assignees, and successors in interest agrees to comply with the following non-discrimination statutes and authorities, including, but not limited to:

- (a) Title VI of the Civil Rights Act of 1964 (42 U.S.C. § 2000d et seq., 78 stat. 252), (prohibits discrimination on the basis of race, color, national origin); and 49 CFR Part 21.
- (b) The Uniform Relocation Assistance and Real Property Acquisition Policies Act of 1970, (42 U.S.C. § 4601), (prohibits unfair treatment of persons displaced or whose property has been acquired because of Federal or Federal-aid programs and projects);
- (c) Federal-Aid Highway Act of 1973, (23 U.S.C. § 324 et seq.), (prohibits discrimination on the basis of sex);
- (d) Section 504 of the Rehabilitation Act of 1973, (29 U.S.C. § 794 et seq.), as amended, (prohibits discrimination on the basis of disability) and 49 CFR Part 27;
- (e) The Age Discrimination Act of 1975, as amended, (42 U.S.C. § 6101 et seq.), (prohibits discrimination on the basis of age);
- (f) Airport and Airway Improvement Act of 1982, (49 USC § 471, Section 47123), as amended, (prohibits discrimination based on race, creed, color, national origin, or sex);
- (g) The Civil Rights Restoration Act of 1987, (PL 100-209), (Broadened the scope, coverage and applicability of Title VI of the Civil Rights Act of 1964, The Age Discrimination Act of 1975 and Section 504 of the Rehabilitation Act of 1973, by expanding the definition of the terms "programs or activities" to include all of the programs or activities of the Federal-aid recipients, sub-recipients and contractors, whether such programs or activities are Federally funded or not);
- (h) Titles II and III of the Americans with Disabilities Act, which prohibit discrimination on the basis of disability in the operation of public entities, public and private transportation systems, places of public accommodation, and certain testing entities (42 U.S.C. §§ 12131-12189) as implemented by Department of Transportation regulations at 49 C.F.R. parts 37 and 38;
- (i) The Federal Aviation Administration's Nondiscrimination statute (49 U.S.C. § 47123) (prohibits discrimination on the basis of race, color, national origin, and sex);
- (j) Executive Order 12898, Federal Actions to Address Environmental Justice in Minority Populations and Low-Income Populations, which ensures Nondiscrimination against minority populations by discouraging programs, policies, and activities with

disproportionately high and adverse human health or environmental effects on minority and low-income populations;

- (k) Executive Order 13166, Improving Access to Services for Persons with Limited English Proficiency, and resulting agency guidance, national origin discrimination includes discrimination because of Limited English proficiency (LEP). To ensure compliance with Title VI, you must take reasonable steps to ensure that LEP persons have meaningful access to your programs (70 Fed. Reg. at 74087 to 74100);
- (l) Title IX of the Education Amendments of 1972, as amended, which prohibits you from discriminating because of sex in education programs or activities (20 U.S.C. 1681 et seq).
- (m) Title VII of the Civil Rights Act of 1964 (42 U.S.C. § 2000e et seq., Pub. L. 88-352), (prohibits employment discrimination on the basis of race, color, religion, sex, or national origin).

(4) Additional Title VI Assurances

***The following Title VI Assurances (Appendices B, C and D) shall apply, as applicable*

(a) Clauses for Deeds Transferring United States Property (1050.2A, Appendix B)

The following clauses will be included in deeds effecting or recording the transfer of real property, structures, or improvements thereon, or granting interest therein from the United States pursuant to the provisions of Assurance 4.

NOW, THEREFORE, the U.S. Department of Transportation as authorized by law and upon the condition that the North Carolina Department of Transportation (NCDOT) will accept title to the lands and maintain the project constructed thereon in accordance with the North Carolina General Assembly, the Regulations for the Administration of the Federal-Aid Highway Program, and the policies and procedures prescribed by the Federal Highway Administration of the U.S. Department of Transportation in accordance and in compliance with all requirements imposed by Title 49, Code of Federal Regulations, U.S. Department of Transportation, Subtitle A, Office of the Secretary, Part 21, Nondiscrimination in Federally-assisted programs of the U.S. Department of Transportation pertaining to and effectuating the provisions of Title VI of the Civil Rights Act of 1964 (78 Stat. 252; 42 U.S.C. § 2000d to 2000d-4), does hereby remise, release, quitclaim and convey unto the NCDOT all the right, title and interest of the U.S. Department of Transportation in and to said lands described in Exhibit A attached hereto and made a part hereof.

(HABENDUM CLAUSE)

TO HAVE AND TO HOLD said lands and interests therein unto the North Carolina Department of Transportation (NCDOT) and its successors forever, subject, however, to the covenants, conditions, restrictions and reservations herein contained as follows, which will remain in effect for the period during which the real property or structures are used for a purpose for which Federal financial assistance is extended or for another purpose involving the provision of similar services or benefits and will be binding on the NCDOT, its successors and assigns.

The NCDOT, in consideration of the conveyance of said lands and interests in lands, does hereby covenant and agree as a covenant running with the land for itself, its successors and assigns, that (1) no person will on the grounds of race, color, or national origin, be excluded from participation in, be denied the benefits of, or be otherwise subjected to discrimination with regard to any facility located wholly or in part on, over, or under such lands hereby conveyed [,] [and]* (2) that the NCDOT will use the lands and interests in lands and interests in lands so conveyed, in compliance with all requirements imposed by or pursuant to Title 49, Code of Federal Regulations, U.S. Department of Transportation, Subtitle A, Office of the Secretary, Part 21, Non-discrimination in Federally-assisted programs of the U.S. Department of Transportation, Effectuation of Title VI of the Civil Rights Act of 1964, and as said Regulations and Acts may be amended [, and (3) that in the event of breach of any of the above-mentioned nondiscrimination conditions, the Department will have a right to enter or re-enter said lands and facilities on said land, and that above described land and facilities will thereon revert to and vest in and become the absolute property of the U.S. Department of Transportation and its assigns as such interest existed prior to this instruction].*

(*Reverter clause and related language to be used only when it is determined that such a clause is necessary in order to make clear the purpose of Title VI.)

(b) Clauses for Transfer of Real Property Acquired or Improved Under the Activity, Facility, or Program (1050.2A, Appendix C)

The following clauses will be included in deeds, licenses, leases, permits, or similar instruments entered into by the North Carolina Department of Transportation (NCDOT) pursuant to the provisions of Assurance 7(a):

1. The (grantee, lessee, permittee, etc. as appropriate) for himself/herself, his/her heirs, personal representatives, successors in interest, and assigns, as a part of the consideration hereof, does hereby covenant and agree [in the case of deeds and leases add "as a covenant running with the land"] that:
 - (i.) In the event facilities are constructed, maintained, or otherwise operated on the property described in this (deed, license, lease, permit, etc.) for a purpose for which a U.S. Department of Transportation activity, facility, or program is extended or for another purpose involving the provision of similar services or benefits, the (grantee, licensee, lessee, permittee, etc.) will maintain and operate such facilities and services in compliance with all requirements imposed by the Acts and Regulations (as may be amended) such that no person on the grounds of race, color, or national origin, will be excluded from participation in, denied the benefits of, or be otherwise subjected to discrimination in the use of said facilities.
2. With respect to licenses, leases, permits, etc., in the event of breach of any of the above Nondiscrimination covenants, the NCDOT will have the right to terminate the (lease, license, permit, etc.) and to enter, re-enter, and repossess said lands and facilities thereon, and hold the same as if the (lease, license, permit, etc.) had never been made or issued. *
3. With respect to a deed, in the event of breach of any of the above Nondiscrimination covenants, the NCDOT will have the right to enter or re-enter the lands and facilities thereon, and the above described lands and facilities will there upon revert to and vest in and become the absolute property of the NCDOT and its assigns. *

(*Reverter clause and related language to be used only when it is determined that such a clause is necessary to make clear the purpose of Title VI.)

(c) Clauses for Construction/Use/Access to Real Property Acquired Under the Activity, Facility or Program (1050.2A, Appendix D)

The following clauses will be included in deeds, licenses, permits, or similar instruments/ agreements entered into by the North Carolina Department of Transportation (NCDOT) pursuant to the provisions of Assurance 7(b):

1. The (grantee, licensee, permittee, etc., as appropriate) for himself/herself, his/her heirs, personal representatives, successors in interest, and assigns, as a part of the consideration hereof, does hereby covenant and agree (in the case of deeds and leases add, "as a covenant running with the land") that (1) no person on the ground of race, color, or national origin, will be excluded from participation in, denied the benefits of, or be otherwise subjected to discrimination in the use of said facilities, (2) that in the construction of any improvements on, over, or under such land, and the furnishing of services thereon, no person on the ground of race, color, or national origin, will be excluded from participation in, denied the benefits of, or otherwise be subjected to discrimination, (3) that the (grantee, licensee, lessee, permittee, etc.) will use the premises in compliance with all other requirements imposed by or pursuant to the Acts and Regulations, as amended, set forth in this Assurance.
2. With respect to (licenses, leases, permits, etc.), in the event of breach of any of the above Non-discrimination covenants, the NCDOT will have the right to terminate the (license, permit, etc., as appropriate) and to enter or re-enter and repossess said land and the facilities thereon, and hold the same as if said (license, permit, etc., as appropriate) had never been made or issued. *
3. With respect to deeds, in the event of breach of any of the above Nondiscrimination covenants, the NCDOT will there upon revert to and vest in and become the absolute property of the NCDOT and its assigns. *

(*Reverter clause and related language to be used only when it is determined that such a clause is necessary to make clear the purpose of Title VI.)

STANDARD SPECIAL PROVISION**ON-THE-JOB TRAINING**

(10-16-07) (Rev. 4-21-15)

Z-10

Description

The North Carolina Department of Transportation will administer a custom version of the Federal On-the-Job Training (OJT) Program, commonly referred to as the Alternate OJT Program. All contractors (existing and newcomers) will be automatically placed in the Alternate Program. Standard OJT requirements typically associated with individual projects will no longer be applied at the project level. Instead, these requirements will be applicable on an annual basis for each contractor administered by the OJT Program Manager.

On the Job Training shall meet the requirements of 23 CFR 230.107 (b), 23 USC – Section 140, this provision and the On-the-Job Training Program Manual.

The Alternate OJT Program will allow a contractor to train employees on Federal, State and privately funded projects located in North Carolina. However, priority shall be given to training employees on NCDOT Federal-Aid funded projects.

Minorities and Women

Developing, training and upgrading of minorities and women toward journeyman level status is a primary objective of this special training provision. Accordingly, the Contractor shall make every effort to enroll minority and women as trainees to the extent that such persons are available within a reasonable area of recruitment. This training commitment is not intended, and shall not be used, to discriminate against any applicant for training, whether a member of a minority group or not.

Assigning Training Goals

The Department, through the OJT Program Manager, will assign training goals for a calendar year based on the contractors' past three years' activity and the contractors' anticipated upcoming year's activity with the Department. At the beginning of each year, all contractors eligible will be contacted by the Department to determine the number of trainees that will be assigned for the upcoming calendar year. At that time the Contractor shall enter into an agreement with the Department to provide a self-imposed on-the-job training program for the calendar year. This agreement will include a specific number of annual training goals agreed to by both parties. The number of training assignments may range from 1 to 15 per contractor per calendar year. The Contractor shall sign an agreement to fulfill their annual goal for the year.\

Training Classifications

The Contractor shall provide on-the-job training aimed at developing full journeyman level workers in the construction craft/operator positions. Preference shall be given to providing training in the following skilled work classifications:

Equipment Operators	Office Engineers
Truck Drivers	Estimators
Carpenters	Iron / Reinforcing Steel Workers
Concrete Finishers	Mechanics
Pipe Layers	Welders

The Department has established common training classifications and their respective training requirements that may be used by the contractors. However, the classifications established are not all-inclusive. Where the training is oriented toward construction applications, training will be allowed in lower-level management positions such as office engineers and estimators. Contractors shall submit new classifications for specific job functions that their employees are performing. The Department will review and recommend for acceptance to FHWA the new classifications proposed by contractors, if applicable. New classifications shall meet the following requirements:

Proposed training classifications are reasonable and realistic based on the job skill classification needs, and

The number of training hours specified in the training classification is consistent with common practices and provides enough time for the trainee to obtain journeyman level status.

The Contractor may allow trainees to be trained by a subcontractor provided that the Contractor retains primary responsibility for meeting the training and this provision is made applicable to the subcontract. However, only the Contractor will receive credit towards the annual goal for the trainee.

Where feasible, 25 percent of apprentices or trainees in each occupation shall be in their first year of apprenticeship or training. The number of trainees shall be distributed among the work classifications on the basis of the contractor's needs and the availability of journeymen in the various classifications within a reasonable area of recruitment.

No employee shall be employed as a trainee in any classification in which they have successfully completed a training course leading to journeyman level status or in which they have been employed as a journeyman.

Records and Reports

The Contractor shall maintain enrollment, monthly and completion reports documenting company compliance under these contract documents. These documents and any other information as requested shall be submitted to the OJT Program Manager.

Upon completion and graduation of the program, the Contractor shall provide each trainee with a certification Certificate showing the type and length of training satisfactorily completed.

Trainee Interviews

All trainees enrolled in the program will receive an initial and Trainee/Post graduate interview conducted by the OJT program staff.

Trainee Wages

Contractors shall compensate trainees on a graduating pay scale based upon a percentage of the prevailing minimum journeyman wages (Davis-Bacon Act). Minimum pay shall be as follows:

60 percent	of the journeyman wage for the first half of the training period
75 percent	of the journeyman wage for the third quarter of the training period
90 percent	of the journeyman wage for the last quarter of the training period

In no instance shall a trainee be paid less than the local minimum wage. The Contractor shall adhere to the minimum hourly wage rate that will satisfy both the NC Department of Labor (NCDOL) and the Department.

Achieving or Failing to Meet Training Goals

The Contractor will be credited for each trainee employed by him on the contract work who is currently enrolled or becomes enrolled in an approved program and who receives training for at least 50 percent of the specific program requirement. Trainees will be allowed to be transferred between projects if required by the Contractor's scheduled workload to meet training goals.

If a contractor fails to attain their training assignments for the calendar year, they may be taken off the NCDOT's Bidders List.

Measurement and Payment

No compensation will be made for providing required training in accordance with these contract documents.

R-5734A

GT-1.1

Macon County

REINFORCED SOIL SLOPES:**(4-19-16)****Description**

Construct reinforced soil slopes (RSS) consisting of select material and geogrid reinforcement in the reinforced zone with erosion control products on slope faces. Slope erosion control includes matting with shoulder and slope borrow or geocells with compost blanket. Construct RSS in accordance with the contract and if included in the plans, Standard Detail No. 1803.01 or 1803.02. RSS are required to reinforce embankments and stabilize slopes at locations shown in the plans and as directed. Define “geogrids” as primary or secondary geogrids and “matting” as coir fiber mat or matting for erosion control. Define “standard RSS” as a RSS that meets a standard reinforced soil slope drawing (Standard Detail No. 1803.01 or 1803.02).

Materials

Refer to Division 10 of the *Standard Specifications*.

Item	Section
Geocells	1056
Matting for Erosion Control	1060-8
Select Materials	1016
Shoulder and Slope Borrow	1019-2

Unless required otherwise in the plans, use Class I, II or III select material in the reinforced zone of RSS. Use seeded compost blankets that meet the *Compost Blanket* provision and coir fiber mat that meets the *Coir Fiber Mat* provision.

(A) Geogrids

Handle and store geogrids in accordance with Article 1056-2 of the *Standard Specifications*. Define “machine direction” (MD) and “cross-machine direction” (CD) for geogrids in accordance with ASTM D4439. Provide Type 1 material certifications for geogrid strengths in the MD and CD in accordance with Article 1056-3 of the *Standard Specifications*. Test geogrids in accordance with ASTM D6637.

Use geogrids with a roll width of at least 4 ft. Use primary geogrids with an “approved” status code and secondary geogrids with an “approved” or “approved for provisional use” status code. Do not use geogrids with an “approved for provisional use” status code for primary geogrids. The list of approved geogrids is available from:

connect.ncdot.gov/resources/Materials/Pages/SoilsLaboratory.aspx

Provide geogrids with design strengths in accordance with the plans. For standard RSS and based on actual RSS angle and height and select material to be used in the reinforced zone at each standard RSS location, provide geogrids with long-term design strengths in accordance with Standard Detail No. 1803.01 or 1803.02. Geogrids are typically approved for ultimate tensile strengths in the MD and CD or long-term design strengths for a 75-year design life in the MD based on material type. Define material type from the website above for select material as follows:

Material Type	Select Material
Borrow	Class I Select Material
Fine Aggregate	Class II or Class III Select Material

R-5734A

GT-1.2

Macon County

If the website does not list a long-term design strength in the MD for an approved geogrid, do not use the geogrid for primary geogrid. If the website does not list a long-term design strength in the CD for an approved geogrid, use a long-term design strength equal to the ultimate tensile strength divided by 7 for the secondary geogrid.

Construction Methods

Before starting RSS construction, the Engineer may require a preconstruction meeting to discuss the construction and inspection of the RSS. If this meeting is required and occurs before all RSS submittals and material certifications have been accepted, additional preconstruction meetings may be required before beginning construction of RSS without accepted submittals. The Resident or District Engineer, Roadway Construction Engineer, Geotechnical Operations Engineer, Contractor and RSS Contractor Superintendent will attend preconstruction meetings.

Control drainage during construction in the vicinity of RSS. Direct run off away from RSS, select material and backfill. Contain and maintain select material and backfill and protect material from erosion.

Excavate as necessary for RSS in accordance with the contract. Maintain a horizontal clearance of at least 12" between the ends of primary geogrids and limits of reinforced zone as shown in the plans. When excavating existing slopes, bench slopes in accordance with Subarticle 235-3(A) of the *Standard Specifications*. Notify the Engineer when excavation is complete. Do not place primary geogrids until excavation dimensions and in-situ material are approved.

Place geogrids within 3" of locations shown in the plans and in slight tension free of kinks, folds, wrinkles or creases. Install geogrids with the orientation, dimensions and number of layers shown in the plans. Contact the Engineer when existing or future obstructions such as foundations, pavements, pipes, inlets or utilities will interfere with geogrids. If necessary, the top geogrid layer may be lowered up to 9" to avoid obstructions. Extend geogrids to slope faces.

Install primary geogrids with the MD perpendicular to the embankment centerline. The MD is the direction of the length or long dimension of the geogrid roll. Unless shown otherwise in the plans, do not splice or overlap primary geogrids in the MD so splices or overlaps are parallel to toe of RSS. Unless shown otherwise in the plans and except for clearances at the ends of primary geogrids, completely cover select material at each primary geogrid layer with geogrid so primary geogrids are adjacent to each other in the CD, i.e., perpendicular to the MD. The CD is the direction of the width or short dimension of the geogrid roll.

Install secondary geogrids with MD parallel to toe of RSS. Secondary geogrids should be continuous for each secondary geogrid layer. If secondary geogrid roll length is too short, overlap ends of secondary geogrid rolls at least 12" in the direction that select material will be placed to prevent lifting the edge of the top geogrid.

Place select material in the reinforced zone in 8" to 10" thick lifts and compact material in accordance with Subarticle 235-3(C) of the *Standard Specifications*. For RSS steeper than 1.5:1 (H:V), compact slope faces with an approved method. Do not use sheepsfoot, grid rollers or other types of compaction equipment with feet. Do not displace or damage geogrids when placing and compacting select material. End dumping directly on geogrids is not permitted. Do not operate heavy equipment on geogrids until they are covered with at least 8" of select material. To prevent damaging geogrids, minimize turning and avoid sudden braking and sharp turns with compaction equipment. Replace any damaged geogrids to the satisfaction of the

R-5734A

GT-1.3

Macon County

Engineer. Construct remaining portions of embankments outside the reinforced zone in accordance with Section 235 of the *Standard Specifications*.

Plate slope faces of RSS with at least 6" of shoulder and slope borrow except when using geocells for slope erosion control. Install slope erosion control as shown in the plans and as soon as possible to prevent damage to slope faces of RSS. If damage occurs, repair RSS and slope faces to the satisfaction of the Engineer before seeding or installing erosion control products. For matting, seed slope faces and cover shoulder and slope borrow with coir fiber mat or matting for erosion control as shown in the plans in accordance with the *Coir Fiber Mat* provision or Section 1631 of the *Standard Specifications*, respectively. Install geocells filled with seeded compost in accordance with the accepted submittals and the *Cellular Confinement Systems* and *Compost Blanket* provisions. Maintain slope erosion control until vegetation is established.

Measurement and Payment

Reinforced Soil Slopes will be measured and paid in square yards. RSS will be measured along the slope faces of RSS before installing slope erosion control as the square yards of RSS. No payment will be made for repairing damaged RSS or slope faces.

The contract unit price for *Reinforced Soil Slopes* will be full compensation for providing labor, tools, equipment and RSS materials, compacting select materials and supplying and placing geogrids, select material, shoulder and slope borrow and any incidentals necessary to construct RSS except for erosion control products. The contract unit price for *Reinforced Soil Slopes* will also be full compensation for excavating and hauling and removing excavated materials to install RSS.

Coir fiber mat and matting for erosion control will be measured and paid in accordance with the *Coir Fiber Mat* provision and Article 1631-4 of the *Standard Specifications*, respectively. Geocells and seeded compost blankets will be will be measured and paid in accordance with the *Cellular Confinement Systems* and *Compost Blanket* provisions, respectively.

Payment will be made under:

Pay Item

Reinforced Soil Slopes

Pay Unit

Square Yard



DocuSigned by:

Jeremy R Hamm

ED7938089E22487...

8/14/2018 3:08:10 PM EDT

R-5734A

GT-2.1

Macon County

SOLDIER PILE RETAINING WALLS**(5-16-17)****1.0 GENERAL**

Construct soldier pile retaining walls consisting of driven or drilled-in steel H-piles with either precast concrete panels in between piles or a cast-in-place reinforced concrete face attached to front of piles unless required otherwise in the plans. Timber lagging is typically used for temporary support of excavations during construction. Provide cast-in-place reinforced concrete coping as required. Design and construct soldier pile retaining walls based on actual elevations and wall dimensions in accordance with the contract and accepted submittals. Use a prequalified Cantilever Wall Contractor to construct soldier pile retaining walls. Define "soldier pile wall" as a soldier pile retaining wall. Define "panel" as a precast concrete panel and "concrete facing" as a cast-in-place reinforced concrete face. Define "pile" as a steel H-pile and "coping" as cast-in-place concrete coping.

2.0 MATERIALS

Refer to the *Standard Specifications*.

Item	Section
Flowable Fill, Excavatable	1000-6
Geosynthetics	1056
Joint Materials	1028
Masonry	1040
Grout, Type 1	1003
Portland Cement Concrete	1000
Reinforcing Steel	1070
Retaining Wall Panels	1077
Select Material	1016
Shoulder Drain Materials	816-2
Steel H-Piles	1084-1
Untreated Timber	1082-2
Welded Stud Shear Connectors	1072-6

Provide Type 2 geotextile for separation geotextiles and Class VI select material (standard size No. 57 stone) for leveling pads and backfilling. Use Class A concrete for concrete facing and coping and Class A concrete that meets Article 450-2 of the *Standard Specifications* or grout for drilled-in piles. Use untreated timber with a thickness of at least 3" and a bending stress of at least 1,000 psi for timber lagging.

Unless required otherwise in the contract, produce panels with a smooth flat final finish that meets Article 1077-11 of the *Standard Specifications*. When noted in the plans, produce panels with an exposed aggregate finish that meets Article 1077-12 of the *Standard Specifications*. Produce panels within 1/4" of the panel dimensions shown in the accepted submittals. Damaged panels with excessive discoloration, chips or cracks as determined by the Engineer will be rejected.

For soldier pile walls with panels, galvanize piles in accordance with Section 1076 of the

R-5734A

GT-2.2

Macon County

Standard Specifications. When noted in the plans, paint galvanized piles in accordance with Article 442-12 of the *Standard Specifications*. Apply the following system to paint galvanized piles gray with waterborne paints that meet Article 1080-11 of the *Standard Specifications*. For painting galvanized piles other colors, contact the Materials and Tests (M&T) Unit for an appropriate paint system.

GRAY PAINT SYSTEM FOR GALVANIZED PILES			
Coat	Color	Dry/Wet Film Thickness (Mils)	
		Min.	Max.
Intermediate	Brown	3.0 DFT	5.0 DFT
Stripe	White	4.0 WFT	7.0 WFT
Topcoat	Gray	2.0 DFT	4.0 DFT
Total		5.0 DFT	9.0 DFT

Store steel materials on blocking at least 12" above the ground and protect it at all times from damage; and when placing in the work make sure it is free from dirt, dust, loose mill scale, loose rust, paint, oil or other foreign materials. Load, transport, unload and store soldier pile wall materials so materials are kept clean and free of damage. Bent, damaged or defective materials will be rejected.

3.0 PRECONSTRUCTION REQUIREMENTS**A. Soldier Pile Wall Surveys**

The Retaining Wall Plans show a plan view, typical sections, details, notes and an elevation or profile view (wall envelope) for each soldier pile wall. Before beginning soldier pile wall design, survey existing ground elevations shown in the plans and other elevations in the vicinity of soldier pile wall locations as needed. For proposed slopes above or below soldier pile walls, survey existing ground elevations to at least 10 ft beyond slope stake points. Based on these elevations, finished grades and actual soldier pile wall dimensions and details, submit revised wall envelopes for acceptance. Use accepted wall envelopes for design.

B. Soldier Pile Wall Designs

For soldier pile wall designs, submit 11 copies of working drawings and 3 copies of design calculations and a PDF copy of each at least 30 days before the preconstruction meeting. Do not begin soldier pile wall construction until a design submittal is accepted.

Use a prequalified Cantilever Wall Design Consultant to design soldier pile walls. Provide designs sealed by a Design Engineer approved as a Geotechnical Engineer (key person) for the Cantilever Wall Design Consultant.

Design soldier pile walls in accordance with the plans and Article 11.8 of the *AASHTO LRFD Bridge Design Specifications* unless otherwise required. Design soldier pile

walls for seismic if walls are located in seismic zone 2 based on Figure 2-1 of the *Structure Design Manual*. Design soldier pile walls for a maximum deflection of 2" or 1.5% of H, whichever is less, with H as shown in the plans.

When noted in the plans, design soldier pile walls for a live load (traffic) surcharge of 250 lb/sf in accordance with Article 11.5.6 of the AASHTO LRFD specifications. For steel beam guardrail with 8 ft posts above soldier pile walls, analyze walls for a horizontal load (P_{H1}) of 300 lb/ft of wall in accordance with Figure 3.11.6.3-2(a) of the AASHTO LRFD specifications. For concrete barrier rail above soldier pile walls, analyze walls for a P_{H1} of 500 lb/ft of wall in accordance with Figure 3.11.6.3-2(a).

When a rock mass shear strength (S_m) is noted in the plans, analyze piles using the equation shown in Figure 3.11.5.6-2 of the AASHTO LRFD specifications to calculate the passive resistance of the rock ($\overline{P_p}$). Use a maximum H-pile spacing of 10 ft. At the Contractor's option, use driven or drilled-in piles for soldier pile walls with concrete facing unless otherwise required. For soldier pile walls with panels, use drilled-in piles unless noted otherwise in the plans. Use concrete or grout for embedded portions of drilled-in piles. Install drilled-in piles by excavating holes with diameters that will result in at least 3" of clearance all around piles.

Provide temporary support of excavations for excavations more than 4 ft deep and timber lagging in accordance with the *AASHTO Guide Design Specifications for Bridge Temporary Works*. At the Contractor's option and when noted in the plans, provide temporary slopes instead of temporary support of excavations. Do not extend temporary slopes outside right-of-way or easement limits. Except for fill sections or when using temporary slopes, backfill voids behind panels, lagging and piles with No. 57 stone. Place separation geotextile between No. 57 stone and overlying fill or pavement sections except when concrete pavement, full depth asphalt or cement treated base is placed directly on stone.

At the Contractor's option, use panels or concrete facing unless required otherwise in the plans. Design panels and concrete facing in accordance with the plans and Section 5 of the *AASHTO LRFD Bridge Design Specifications*. Provide reinforcing steel of sufficient density to satisfy Article 5.7.3.4 of the AASHTO LRFD specifications. Use panels or concrete facing with the dimensions shown in the plans and attach facing to front of H-piles with welded stud shear connectors.

Use No. 57 stone for aggregate leveling pads. Use 6" thick leveling pads beneath panels and concrete facing. Unless required otherwise in the plans, embed top of leveling pads at least 12" below bottom of walls shown in the plans.

Provide wall drainage systems consisting of geocomposite sheet drains, an aggregate shoulder drain and outlet components. Place sheet drains with a horizontal spacing of no more than 10 ft and center drains between adjacent piles. Attach sheet drains to front of timber lagging or back of panels or concrete facing and connect drains to aggregate leveling pads. Locate a continuous aggregate shoulder drain along the base of panels or concrete facing in front of piles and leveling pads. Provide aggregate

R-5734A

GT-2.4

Macon County

shoulder drains and outlet components in accordance with Standard Drawing No. 816.02 of the *Roadway Standard Drawings*.

Unless required otherwise in the plans, use cast-in-place reinforced concrete coping at top of soldier pile walls with panels. Use coping dimensions shown in the plans and at the Contractor's option, connect coping to panels with dowels or extend coping down back of panels. When concrete barrier rail is required above soldier pile walls, use concrete barrier rail with moment slab as shown in the plans.

Submit working drawings and design calculations for acceptance in accordance with Article 105-2 of the *Standard Specifications*. Submit working drawings showing plan views, wall profiles with pile locations, typical sections and details of piles, drainage, temporary support, leveling pads, panels and concrete facing. If necessary, include details on working drawings for coping, concrete barrier rail with moment slab and obstructions extending through walls or interfering with piles, barriers or moment slabs. Submit design calculations including deflection calculations for each wall section with different surcharge loads, geometry or material parameters. Include analysis of temporary conditions in design calculations. When designing soldier pile walls with computer software, a hand calculation is required for the tallest wall section.

C. Soldier Pile Wall Construction Plan

Submit 4 copies and a PDF copy of a soldier pile wall construction plan at least 30 days before the preconstruction meeting. Do not begin soldier pile wall construction until the construction plan submittal is accepted. Provide project specific information in the soldier pile wall construction plan including a detailed construction sequence. For driven piles, submit proposed pile driving methods and equipment in accordance with Subarticle 450-3(D)(2) of the *Standard Specifications*. For drilled-in piles, submit installation details including drilling equipment and methods for stabilizing and filling holes. Provide details in the construction plan of excavations including temporary support and any other information shown in the plans or requested by the Engineer.

If alternate construction procedures are proposed or necessary, a revised soldier pile wall construction plan submittal may be required. If the work deviates from the accepted submittal without prior approval, the Engineer may suspend soldier pile wall construction until a revised plan is accepted.

D. Preconstruction Meeting

Before starting soldier pile wall construction, hold a preconstruction meeting to discuss the construction and inspection of the soldier pile walls. If this meeting occurs before all soldier pile wall submittals have been accepted, additional preconstruction meetings may be required before beginning construction of soldier pile walls without accepted submittals. The Resident or Bridge Maintenance Engineer, Bridge Construction Engineer, Geotechnical Operations Engineer, Contractor and Cantilever Wall Contractor Superintendent will attend preconstruction meetings.

4.0 CONSTRUCTION METHODS

R-5734A

GT-2.5

Macon County

Control drainage during construction in the vicinity of soldier pile walls. Direct run off away from soldier pile walls and areas above and behind walls. Contain and maintain No. 57 stone and backfill and protect material from erosion.

Notify the Engineer before blasting in the vicinity of soldier pile walls. Perform blasting in accordance with the contract. Unless required otherwise in the plans, install foundations located behind soldier pile walls before beginning wall construction if the horizontal distance to the closest foundation is less than the height of the tallest wall section.

Install soldier pile walls in accordance with the accepted submittals and as directed. Do not excavate behind soldier pile walls unless a temporary slope is shown in the accepted submittals. If overexcavation occurs and is not approved, repair walls with an approved method and a revised soldier pile wall design or construction plan may be required.

A. Piles

If a temporary slope is shown in the accepted submittals, excavate the slope before installing piles. Otherwise, install piles before excavating for soldier pile walls. Weld stud shear connectors to piles in accordance with Article 1072-6 of the *Standard Specifications*.

Install piles within 1" of horizontal and vertical alignment shown in the accepted submittals and with no negative batter (piles leaning forward). Minimize alignment variations between piles for soldier pile walls with concrete facing since variations can result in thicker concrete facing in some locations in order to provide the minimum required facing thickness elsewhere. Locate piles so the minimum required concrete facing thickness, if applicable, and roadway clearances are maintained for variable pile alignments.

Install piles to the required elevations in accordance with Subarticles 450-3(D) and 450-3(E) of the *Standard Specifications*. Piles may be installed with a vibratory hammer as approved by the Engineer. Do not splice piles. If necessary, cut off piles at elevations shown in the accepted submittals along a plane normal to the pile axis.

Use pile excavation to install drilled-in piles. If overexcavation occurs, fill to required elevations with No. 57 stone before setting piles. After filling holes with concrete or grout to the elevations shown in the accepted submittals, remove any fluids and fill remaining portions of holes with flowable fill. Cure concrete or grout at least 7 days before excavating.

Notify the Engineer if refusal is reached before pile excavation or driven piles attain the required penetration. When this occurs, a revised soldier pile wall design or construction plan submittal may be required. When a minimum pile penetration into rock is noted in the plans, rock is as determined by the Engineer.

B. Excavation

If a temporary slope is shown in the accepted submittals, excavate the slope as shown.

R-5734A

GT-2.6

Macon County

Otherwise, excavate in front of piles from the top down in accordance with the accepted submittals. Excavate in staged horizontal lifts with a maximum height of 5 ft. Use timber lagging or an alternate approved method for temporary support of excavations in accordance with the accepted submittals.

Install temporary support within 24 hours of excavating each lift unless otherwise approved. The installation may be delayed if it can be demonstrated that delays will not adversely affect excavation stability. If excavation faces will be exposed for more than 24 hours, use polyethylene sheets anchored at top and bottom of lifts to protect excavation faces from changes in moisture content.

If an excavation becomes unstable at any time, suspend soldier pile wall construction and temporarily stabilize the excavation by immediately placing an earth berm up against the unstable excavation face. When this occurs, repair walls with an approved method and a revised soldier pile wall design or construction plan may be required.

Remove flowable fill and material in between piles as necessary to install timber lagging. Position lagging with at least 3" of contact in the horizontal direction between the lagging and pile flanges. Do not excavate the next lift until temporary support for the current lift is accepted.

C. Wall Drainage Systems

Install wall drainage systems as shown in the accepted submittals and in accordance with Section 816 of the *Standard Specifications*. Place geocomposite sheet drains with the geotextile side facing away from wall faces. Secure sheet drains so drains are in continuous contact with surfaces to which they are attached and allow for full flow the entire height of soldier pile walls. Discontinuous sheet drains are not allowed. If splices are needed, overlap sheet drains at least 12" so flow is not impeded. Connect sheet drains to aggregate leveling pads by embedding drain ends at least 4" into No. 57 stone.

D. Leveling Pads, Panels, Coping and Concrete Facing

Construct aggregate leveling pads at elevations and with dimensions shown in the accepted submittals. Compact leveling pads with a vibratory compactor to the satisfaction of the Engineer.

Set panels against pile flanges as shown in the accepted submittals. Position panels with at least 2" of contact in the horizontal direction between the panels and pile flanges. If contact cannot be maintained, remove panels, fill gaps with joint filler and reset panels. Securely support panels until enough No. 57 stone or backfill is placed to hold panels in place.

Construct coping as shown in the accepted submittals and Subarticle 452-3(C) of the *Standard Specifications*. When single faced precast concrete barrier is required in front of and against soldier pile walls, stop coping just above barrier so coping does not interfere with placing barrier up against wall faces. If the gap between a single faced

R-5734A

GT-2.7

Macon County

barrier and wall face is wider than 2", fill gap with Class V select material (standard size No. 78M stone). Otherwise, fill gap with backer rod and seal joint between barrier and soldier pile wall with silicone sealant.

Construct concrete facing in accordance with the accepted submittals and Section 420 of the *Standard Specifications*. Do not remove forms until concrete attains a compressive strength of at least 2,400 psi. Unless required otherwise in the plans, provide a Class 2 surface finish for concrete facing that meets Subarticle 420-17(F) of the *Standard Specifications*. Construct concrete facing joints at a spacing of 10 ft to 12 ft unless required otherwise in the plans. Make 1/2" thick expansion joints that meet Article 420-10 of the *Standard Specifications* for every third joint and 1/2" deep grooved contraction or sawed joints that meet Subarticle 825-10(B) or 825-10(E) respectively for the remaining joints. Stop reinforcing steel for concrete facing 2" on either side of expansion joints.

If a brick veneer is required, construct brick masonry in accordance with Section 830 of the *Standard Specifications*. Anchor brick veneers to soldier pile walls with approved brick to concrete type anchors in accordance with the manufacturer's instructions. Space anchors no more than 16" apart in the vertical direction and no more than 32" apart in the horizontal direction with each row of anchors staggered 16" from the row above and below.

Seal joints above and behind soldier pile walls between coping or concrete facing and concrete slope protection with silicone sealant.

E. Backfill

For fill sections or if a temporary slope is shown in the accepted submittals, backfill behind piles, panels and concrete facing in accordance with Article 410-8 of the *Standard Specifications*. Otherwise, backfill voids behind panels, lagging and piles with No. 57 stone as shown in the accepted submittals. Ensure all voids between panels and lagging and between piles, lagging and excavation faces are filled with No. 57 stone. Compact stone to the satisfaction of the Engineer. When separation geotextiles are required, overlap adjacent geotextiles at least 18" and hold separation geotextiles in place with wire staples or anchor pins as needed.

F. Pile Coatings

For soldier pile walls with panels, clean exposed galvanized or painted surfaces of piles with a 2,500 psi pressure washer after wall construction is complete. Repair galvanized surfaces that are exposed and damaged in accordance with Article 1076-7 of the *Standard Specifications*. Repair painted surfaces that are exposed and damaged by applying 4.0 to 7.0 mils wet film thickness of a topcoat to damaged areas with brushes or rollers. Use the same paint for damaged areas that was used for the topcoat when painting piles initially. Feather or taper topcoats in damaged areas to be level with surrounding areas.

5.0 MEASUREMENT AND PAYMENT

R-5734A

GT-2.8

Macon County

Soldier Pile Retaining Walls will be measured and paid in square feet. Soldier pile walls will be measured as the square feet of wall face area with the pay height equal to the difference between top of wall and top of leveling pad elevations. Define “top of wall” as top of coping or top of panels or concrete facing for soldier pile walls without coping.

The contract unit price for *Soldier Pile Retaining Walls* will be full compensation for providing designs, submittals, labor, tools, equipment and soldier pile wall materials, installing piles, excavating, backfilling, hauling and removing excavated materials and supplying temporary support of excavations, wall drainage systems, leveling pads, panels, concrete facing, No. 57 stone, geotextiles and any incidentals necessary to construct soldier pile walls. The contract unit price for *Soldier Pile Retaining Walls* will also be full compensation for coping, pile coatings, backer rod and silicone sealant, No. 78M stone and brick veneers, if required. No additional payment will be made and no extension of completion date or time will be allowed for repairing overexcavations or unstable excavations or thicker concrete facing.

The contract unit price for *Soldier Pile Retaining Walls* does not include the cost for ditches, fences, handrails, barrier or guardrail associated with soldier pile walls as these items will be paid for elsewhere in the contract.

Where it is necessary to provide backfill material behind soldier pile walls from sources other than excavated areas or borrow sources used in connection with other work in the contract, payment for furnishing and hauling such backfill material will be paid as extra work in accordance with Article 104-7 of the *Standard Specifications*. Placing and compacting such backfill material is not considered extra work but is incidental to the work being performed.

Payment will be made under:

Pay Item

Soldier Pile Retaining Walls

Pay Unit

Square Foot



DocuSigned by:
Jeremy R Hamm

ED7938089E22487...
8/14/2018 3:08:10 PM EDT

R-5734A

GT-3.1

Macon County

TEMPORARY SOIL NAIL WALLS:**(1-16-18)****Description**

Construct temporary soil nail walls consisting of soil nails spaced at a regular pattern and connected to a reinforced shotcrete face. A soil nail consists of a steel bar grouted in a drilled hole inclined at an angle below horizontal. At the Contractor's option, use temporary soil nail walls instead of temporary shoring for full cut sections. Design and construct temporary soil nail walls based on actual elevations and wall dimensions in accordance with the contract and accepted submittals. Use a prequalified Anchored Wall Contractor to construct temporary soil nail walls. Define "soil nail wall" as a temporary soil nail wall and "Soil Nail Wall Contractor" as the Anchored Wall Contractor installing soil nails and applying shotcrete. Define "nail" as a soil nail.

Provide positive protection for soil nail walls at locations shown in the plans and as directed. See *Temporary Shoring* provision for positive protection types and definitions.

Materials

Refer to Division 10 of the *Standard Specifications*.

Item	Section
Geocomposites	1056
Neat Cement Grout, Type 2	1003
Reinforcing Steel	1070
Shotcrete	1002
Select Material, Class IV	1016
Steel Plates	1072-2

Use Class IV select material for temporary guardrail. Provide soil nails consisting of grouted steel bars and nail head assemblies. Use deformed steel bars that meet AASHTO M 275 or M 31, Grade 60 or 75. Splice bars in accordance with Article 1070-9 of the *Standard Specifications*.

Fabricate centralizers from schedule 40 PVC plastic pipe or tube, steel or other material not detrimental to steel bars (no wood). Size centralizers to position bars within 1" of drill hole centers and allow tremies to be inserted to ends of holes. Use centralizers that do not interfere with grout placement or flow around bars.

Provide nail head assemblies consisting of nuts, washers and bearing plates. Use steel plates for bearing plates and steel washers and hex nuts recommended by the Soil Nail Manufacturer.

Provide Type 6 material certifications for soil nail materials in accordance with Article 106-3 of the *Standard Specifications*. Store steel materials on blocking at least 12" above the ground and protect it at all times from damage; and when placing in the work make sure it is free from dirt, dust, loose mill scale, loose rust, paint, oil or other foreign materials. Load, transport, unload and store soil nail wall materials so materials are kept clean and free of damage. Bent, damaged or defective materials will be rejected.

Preconstruction Requirements**(A) Concrete Barrier**

Define "clear distance" behind concrete barrier as the horizontal distance between the

R-5734A

GT-3.2

Macon County

barrier and edge of pavement. The minimum required clear distance for concrete barrier is shown in the plans. At the Contractor's option or if the minimum required clear distance is not available, set concrete barrier next to and up against traffic side of soil nail walls except for barrier above walls. Concrete barrier with the minimum required clear distance is required above soil nail walls.

(B) Temporary Guardrail

Define "clear distance" behind temporary guardrail as the horizontal distance between guardrail posts and soil nail walls. At the Contractor's option or if clear distance for soil nail walls is less than 4 ft, use temporary guardrail with 8 ft posts and a clear distance of at least 2.5 ft. Place ABC in clear distance and around guardrail posts instead of pavement.

(C) Soil Nail Wall Designs

Before beginning soil nail wall design, survey existing ground elevations in the vicinity of wall locations to determine actual design heights (H). Use a prequalified Anchored Wall Design Consultant to design soil nail walls. Provide designs sealed by a Design Engineer approved as a Geotechnical Engineer (key person) for the Anchored Wall Design Consultant.

Submit PDF files of working drawings and design calculations for soil nail wall designs in accordance with Article 105-2 of the *Standard Specifications*. Submit working drawings showing plan views, wall profiles, typical sections and details of soil nail wall design and construction sequence. Include details in working drawings of soil nail locations, unit grout/ground bond strengths, shotcrete reinforcement and if necessary, obstructions extending through walls or interfering with nails. Include details in construction sequence of excavation, grouting, installing reinforcement, nail testing and shotcreting with mix designs and shotcrete nozzleman certifications. Do not begin soil nail wall construction until a design submittal is accepted.

Design soil nail walls in accordance with the plans and allowable stress design method in the *FHWA Geotechnical Engineering Circular No. 7 "Soil Nail Walls"* (Publication No. FHWA-IF-03-017) unless otherwise required.

Design soil nails that meet the following unless otherwise approved:

- (1) Horizontal and vertical spacing of at least 3 ft,
- (2) Inclination of at least 12° below horizontal and
- (3) Diameter of 4" to 10".

Do not extend nails beyond right-of-way or easement limits. If existing or future obstructions such as foundations, pavements, pipes, inlets or utilities will interfere with nails, maintain a clearance of at least 6" between obstructions and nails.

Design soil nail walls for a traffic surcharge of 250 psf if traffic will be above and within H of walls. This traffic surcharge does not apply to construction traffic. Design soil nail walls for any construction surcharge if construction traffic will be above and within H of walls. For temporary guardrail with 8 ft posts above soil nail walls, analyze walls for a horizontal load of 300 lb/ft of wall.

R-5734A

GT-3.3

Macon County

Place geocomposite drain strips with a horizontal spacing of no more than 10 ft and center strips between adjacent nails. Attach drain strips to excavation faces. Use shotcrete at least 4" thick and reinforce shotcrete with #4 waler bars around nail heads. Two waler bars (one on each side of nail head) in the horizontal and vertical directions are required for a total of 4 bars per nail.

(D) Preconstruction Meeting

Before starting soil nail wall construction, hold a preconstruction meeting to discuss the construction, inspection and testing of the soil nail walls. If this meeting occurs before all soil nail wall submittals have been accepted, additional preconstruction meetings may be required before beginning construction of soil nail walls without accepted submittals. The Resident, District or Bridge Maintenance Engineer, Area Construction Engineer, Geotechnical Operations Engineer, Contractor and Soil Nail Wall Contractor Superintendent will attend preconstruction meetings.

(E) Preconstruction Meeting

Before beginning wall construction, provide preconstruction test panels in accordance with Subarticle 1002-3(D) of the *Standard Specifications*.

Construction Methods

Control drainage during construction in the vicinity of soil nail walls. Direct run off away from soil nail walls and areas above and behind walls.

Install foundations located behind soil nail walls before beginning wall construction. Do not excavate behind soil nail walls. If overexcavation occurs, repair walls with an approved method and a revised soil nail wall design may be required.

Install positive protection in accordance with the contract and accepted submittals. Use PCB in accordance with Section 1170 of the *Standard Specifications* and Roadway Standard Drawing No. 1170.01. Use temporary guardrail in accordance with Section 862 of the *Standard Specifications* and Roadway Standard Drawing No. 862.01, 862.02 and 862.03.

(A) Excavation

Excavate for soil nail walls from the top down in accordance with the accepted submittals. Excavate in staged horizontal lifts with no negative batter (excavation face leaning forward). Excavate lifts in accordance with the following:

- (1) Heights not to exceed vertical nail spacing,
- (2) Bottom of lifts no more than 3 ft below nail locations for current lift and
- (3) Horizontal and vertical alignment within 6" of location shown in the accepted submittals.

Remove any cobbles, boulders, rubble or debris that will protrude more than 2" into the required shotcrete thickness. Rocky ground such as colluvium, boulder fills and weathered rock may be difficult to excavate without leaving voids.

Apply shotcrete to excavation faces within 24 hours of excavating each lift unless otherwise approved. Shotcreting may be delayed if it can be demonstrated that delays will not adversely affect excavation stability. If excavation faces will be exposed for

R-5734A

GT-3.4

Macon County

more than 24 hours, use polyethylene sheets anchored at top and bottom of lifts to protect excavation faces from changes in moisture content.

If an excavation becomes unstable at any time, suspend soil nail wall construction and temporarily stabilize the excavation by immediately placing an earth berm up against the unstable excavation face. When this occurs, repair walls with an approved method and a revised soil nail wall design may be required.

Do not excavate the next lift until nail installations and testing and shotcrete application for the current lift are accepted and grout and shotcrete for the current lift have cured at least 3 days and 1 day, respectively.

(B) Soil Nails

Drill and grout nails the same day and do not leave drill holes open overnight. Control drilling and grouting to prevent excessive ground movements, damaging structures and pavements or fracturing rock and soil formations. If ground heave or subsidence occurs, suspend soil nail wall construction and take corrective action to minimize movement. If property damage occurs, make repairs with an approved method and a revised soil nail wall design may be required.

(1) Drilling

Use drill rigs of the sizes necessary to install soil nails and with sufficient capacity to drill through whatever materials are encountered. Drill straight and clean holes with the dimensions and inclination shown in the accepted submittals. Drill holes within 6" of locations and 2° of inclination shown in the accepted submittals unless otherwise approved.

Stabilize drill holes with temporary casings if unstable, caving or sloughing material is anticipated or encountered. Do not use drilling fluids to stabilize drill holes or remove cuttings.

(2) Steel Bars

Center steel bars in drill holes with centralizers. Securely attach centralizers along bars at no more than 8 ft centers. Attach uppermost and lowermost centralizers 18" from excavation faces and ends of holes.

Do not insert steel bars into drill holes until hole locations, dimensions, inclination and cleanliness are approved. Do not vibrate, drive or otherwise force bars into holes. If a steel bar cannot be completely and easily inserted into a drill hole, remove the bar and clean or redrill the hole.

(3) Grouting

Remove oil, rust inhibitors, residual drilling fluids and similar foreign materials from holding tanks/hoppers, stirring devices, pumps, lines, tremie pipes and any other equipment in contact with grout before use. Measure grout temperature, density and flow during grouting with at least the same frequency grout cubes are made for compressive strength. Perform density and flow field tests in the presence of the Engineer in accordance with American National Standards Institute/American Petroleum Institute Recommended Practice 13B-1 (Section 4,

R-5734A

GT-3.5

Macon County

Mud Balance) and ASTM C939 (Flow Cone), respectively.

Inject grout at the lowest point of drill holes through tremies, e.g., grout tubes, casings, hollow-stem augers or drill rods, in one continuous operation. Fill drill holes progressively from ends of holes to excavation faces and withdraw tremies at a slow even rate as holes are filled to prevent voids in grout. Extend tremies into grout at least 5 ft at all times except when grout is initially placed in holes.

Provide grout free of segregation, intrusions, contamination, structural damage or inadequate consolidation (honeycombing). Cold joints in grout are not allowed except for test nails. Remove any temporary casings as grout is placed and record grout volume for each drill hole.

(4) **Nail Heads**

Install nail head assemblies after shotcreting. Before shotcrete reaches initial set, seat bearing plates and tighten nuts so plates contact shotcrete uniformly. If uniform contact is not possible, install nail head assemblies on mortar pads so nail heads are evenly loaded.

(C) **Drain Strips**

Install geocomposite drain strips as shown in the accepted submittals. Before installing shotcrete reinforcement, place drain strips with the geotextile side against excavation faces. For highly irregular faces and at the discretion of the Engineer, drain strips may be placed after shotcreting over weep holes through the shotcrete. Hold drain strips in place with anchor pins so strips are in continuous contact with surfaces to which they are attached and allow for full flow the entire height of soil nail walls. Discontinuous drain strips are not allowed. If splices are needed, overlap drain strips at least 12" so flow is not impeded. Cut off excess drain strip length and expose strip ends below shotcrete when soil nail wall construction is complete.

(D) **Shotcrete**

Clean ungrouted zones of drill holes and excavation faces of loose materials, mud, rebound and other foreign material. Moisten surfaces to receive shotcrete. Install shotcrete reinforcement in accordance with the contract and accepted submittals. Secure reinforcing steel so shooting does not displace or vibrate reinforcement. Install approved thickness gauges on 5 ft centers in the horizontal and vertical directions to measure shotcrete thickness.

Apply shotcrete in accordance with the contract, accepted submittals and Subarticle 1002-3(F) of the *Standard Specifications*. Use approved shotcrete nozzlemen who made satisfactory preconstruction test panels to apply shotcrete. Direct shotcrete at right angles to excavation faces except when shooting around reinforcing steel. Rotate nozzle steadily in small circular patterns and apply shotcrete from bottom of lifts up.

Make shotcrete surfaces uniform and free of sloughing or sagging. Completely fill ungrouted zones of drill holes and any other voids with shotcrete. Taper construction joints to a thin edge over a horizontal distance of at least the shotcrete thickness. Wet joint surfaces before shooting adjacent sections.

Repair surface defects as soon as possible after shooting. Remove any shotcrete which

R-5734A

GT-3.6

Macon County

lacks uniformity, exhibits segregation, honeycombing or lamination or contains any voids or sand pockets and replace with fresh shotcrete to the satisfaction of the Engineer. Protect shotcrete from freezing and rain until shotcrete reaches initial set.

(E) Construction Records

Provide 2 copies of soil nail wall construction records within 24 hours of completing each lift. Include the following in construction records:

- (1) Names of Soil Nail Wall Contractor, Superintendent, Nozzleman, Drill Rig Operator, Project Manager and Design Engineer;
- (2) Wall description, county, Department's contract, TIP and WBS element number;
- (3) Wall station and number and lift location, dimensions, elevations and description;
- (4) Nail locations, dimensions and inclinations, bar types, sizes and grades and temporary casing information;
- (5) Date and time drilling begins and ends, steel bars are inserted into drill holes, grout and shotcrete are mixed and arrives on-site and grout placement and shotcrete application begins and ends;
- (6) Grout volume, temperature, flow and density records;
- (7) Ground and surface water conditions and elevations if applicable;
- (8) Weather conditions including air temperature at time of grout placement and shotcrete application; and
- (9) All other pertinent details related to soil nail wall construction.

After completing each soil nail wall or stage of a wall, provide a PDF file of all corresponding construction records.

Nail Testing

"Proof tests" are performed on nails incorporated into walls, i.e., production nails. Define "test nail" as a nail tested with a proof test. Proof tests are typically required for at least one nail per nail row per soil nail wall or at least 5% of production nails, whichever is greater. More or less test nails may be required depending on subsurface conditions encountered. The Engineer will determine the number and locations of proof tests required. Do not test nails until grout and shotcrete attain the required 3 day compressive strength.

(A) Test Equipment

Use the following equipment to test nails:

- (1) Two dial gauges with rigid supports,
- (2) Hydraulic jack and pressure gauge and
- (3) Jacking block or reaction frame.

Provide dial gauges with enough range and precision to measure the maximum test nail movement to 0.001". Use pressure gauges graduated in 100 psi increments or less. Submit identification numbers and calibration records for load cells, jacks and pressure gauges with the soil nail wall design. Calibrate each jack and pressure gauge as a unit.

R-5734A

GT-3.7

Macon County

Align test equipment to uniformly and evenly load test nails. Use a jacking block or reaction frame that does not damage or contact shotcrete within 3 ft of nail heads. Place dial gauges opposite each other on either side of test nails and align gauges within 5° of bar inclinations. Set up test equipment so resetting or repositioning equipment during nail testing is not needed.

(B) Test Nails

Test nails include both unbonded and bond lengths. Grout only bond lengths before nail testing. Provide unbonded and bond lengths of at least 3 ft and 10 ft, respectively.

Steel bars for production nails may be overstressed under higher test nail loads. If necessary, use larger size or higher grade bars with more capacity for test nails instead of shortening bond lengths to less than the minimum required.

(C) Proof Tests

Determine maximum bond length (L_B) using the following:

$$L_B \leq (C_{RT} \times A_t \times f_y) / (Q_{ALL} \times 1.5)$$

Where,

- L_B = bond length (ft),
 C_{RT} = reduction coefficient, 0.9 for Grade 60 and 75 bars or 0.8 for Grade 150 bars,
 A_t = bar area (in²),
 f_y = bar yield stress (ksi) and
 Q_{ALL} = allowable unit grout/ground bond strength (kips/ft).

Determine design test load (DTL) based on as-built bond length and allowable unit grout/ground bond strength using the following:

$$DTL = L_B \times Q_{ALL}$$

Where,

- DTL = design test load (kips).

Perform proof tests by incrementally loading nails to failure or a load of 150% of DTL based on the following schedule:

Load	Hold Time
AL*	Until movement stabilizes
0.25 DTL	Until movement stabilizes
0.50 DTL	Until movement stabilizes
0.75 DTL	Until movement stabilizes
1.00 DTL	Until movement stabilizes
1.25 DTL	Until movement stabilizes
1.50 DTL	10 or 60 minutes (creep test)
AL*	1 minute

* Alignment load (AL) is the minimum load needed to align test equipment and should not exceed 0.05 DTL.

Reset dial gauges to zero after applying alignment load. Record test nail movement at

R-5734A

GT-3.8

Macon County

each load increment and monitor test nails for creep at the 1.5 DTL load increment. Measure and record movement during creep test at 1, 2, 3, 5, 6 and 10 minutes. If test nail movement between 1 and 10 minutes is greater than 0.04", maintain the 1.5 DTL load increment for an additional 50 minutes and record movement at 20, 30, 50 and 60 minutes. Repump jack as needed to maintain load during hold times.

(D) Test Nail Acceptance

Submit 2 copies of test nail records including load versus movement and time versus creep movement plots within 24 hours of completing each proof test. The Engineer will review the test nail records to determine if test nails are acceptable. Test nail acceptance is based in part on the following criteria.

- (1) Total movement during creep test is less than 0.04" between the 1 and 10 minute readings or less than 0.08" between the 6 and 60 minute readings and creep rate is linear or decreasing throughout hold time.
- (2) Total movement at maximum load exceeds 80% of the theoretical elastic elongation of the unbonded length.
- (3) Pullout failure does not occur at or before the 1.5 DTL load increment. Define "pullout failure" as the inability to increase load while movement continues. Record pullout failure load as part of test nail data.

Maintain stability of unbonded lengths for subsequent grouting. If a test nail is accepted but the unbonded length cannot be satisfactorily grouted, do not incorporate the test nail into the soil nail wall and add another production nail to replace the test nail.

If the Engineer determines a test nail is unacceptable, either perform additional proof tests on adjacent production nails or revise the soil nail design or installation methods for the production nails represented by the unacceptable test nail as determined by the Engineer. Submit a revised soil nail wall design for acceptance, provide an acceptable test nail with the revised design or installation methods and install additional production nails for the nails represented by the unacceptable test nail.

After completing nail testing for each soil nail wall or stage of a wall, provide a PDF file of all corresponding test nail records.

Measurement and Payment

Temporary soil nail walls will be measured and paid in square feet. Temporary soil nail walls will be paid for at the contract unit price for *Temporary Shoring*. Temporary soil nail walls will be measured as the square feet of exposed wall face area. No measurement will be made for any embedment or pavement thickness above soil nail walls.

The contract unit price for *Temporary Shoring* will be full compensation for providing soil nail wall designs, submittals, labor, tools, equipment and soil nail wall materials, excavating, hauling and removing excavated materials, installing and testing soil nails, grouting, shotcreting and supplying drain strips and any incidentals necessary to construct soil nail walls. No additional payment will be made and no extension of completion date or time will be allowed for repairing property damage, overexcavations or unstable excavations, unacceptable test nails or thicker shotcrete.

R-5734A

GT-3.9

Macon County

No payment will be made for temporary shoring not shown in the plans or required by the Engineer including shoring for OSHA reasons or the Contractor's convenience. No value engineering proposals will be accepted based solely on revising or eliminating shoring locations shown in the plans or estimated quantities shown in the bid item sheets as a result of actual field measurements or site conditions.

PCB will be measured and paid in accordance with Section 1170 of the *Standard Specifications*. No additional payment will be made for anchoring PCB for soil nail walls. Costs for anchoring PCB will be incidental to soil nail walls.

Temporary guardrail will be measured and paid for in accordance with Section 862 of the *Standard Specifications*.



DocuSigned by:

Jeremy R Hamm

ED7938089E22487...

8/14/2018 3:08:10 PM EDT



DocuSigned by:
Betsy L. Watson
35E67BB34F8743F...

10/22/2018

OVERHEAD AND DYNAMIC MESSAGE SIGN FOUNDATIONS

Description

Sign foundations include foundations for overhead and dynamic message signs (DMS) supported by metal poles or upright trusses. Sign foundations consist of footings with pedestals or drilled piers with or without grade beams or wings, conduit and anchor rod assemblies. Construct sign foundations in accordance with the contract and accepted submittals. Define “cantilever sign” as an overhead cantilever sign support in accordance with Figure 1-1 of the *AASHTO Standard Specifications for Structural Supports for Highway Signs, Luminaires and Traffic Signals*.

Materials

Use sign foundation materials that meet the *Foundations and Anchor Rod Assemblies for Metal Poles* provision.

Assumed Subsurface Conditions

Assume the following soil parameters and groundwater elevation for sign foundations unless these subsurface conditions are not applicable to sign locations:

- (A) Unit weight (γ) = 120 lb/cf,
- (B) Friction angle (ϕ) = 30°,
- (C) Cohesion (c) = 0 lb/sf and
- (D) Groundwater 7 ft below finished grade.

A subsurface investigation is required if the Engineer determines these assumed subsurface conditions do not apply to a sign location and the sign cannot be moved. Subsurface conditions requiring a subsurface investigation include but are not limited to weathered or hard rock, boulders, very soft or loose soil, muck or shallow groundwater. No extension of completion date or time will be allowed for subsurface investigations.

Subsurface Investigations

Use a prequalified geotechnical consultant to perform one standard penetration test (SPT) boring in accordance with ASTM D1586 at each sign location requiring a subsurface investigation. Rough grade sign locations to within 2 ft of finished grade before beginning drilling. Drill borings to 2 drilled pier diameters below anticipated pier tip elevations or refusal, whichever is higher.

Use the computer software gINT version V8i or later manufactured by Bentley Systems, Inc. with the current NCDOT gINT library and data template to produce SPT boring logs. Provide boring logs sealed by a geologist or engineer licensed in the state of North Carolina.

Sign Foundation Designs

Design sign foundations for the wind zone and clearances shown in the plans and the slope of finished grade at each sign location. Use the assumed soil parameters and groundwater elevation above for sign foundation designs unless a subsurface investigation is required. For sign locations requiring a subsurface investigation, design sign foundations for the subsurface conditions at each sign location. Design footings, pedestals, drilled piers, grade beams and wings in accordance with the 6th Edition of the *AASHTO Standard Specifications for Structural Supports for Highway Signs, Luminaires and Traffic Signals*. In some instances, conflicts with drainage structures may dictate sign foundation types.

Design footings in accordance with Section 4.4 of the *AASHTO Standard Specifications for Highway Bridges*. Do not use an allowable bearing pressure of more than 3,000 lb/sf for footings.

Design drilled piers for side resistance only in accordance with Section 4.6 of the *AASHTO Standard Specifications for Highway Bridges* except reduce ultimate side resistance by 25% for uplift. Use the computer software LPILE version 6.0 or later manufactured by Ensoft, Inc. to analyze drilled piers. Provide drilled pier designs with a horizontal deflection of less than 1" at top of piers. For cantilever signs with single drilled pier foundations supporting metal poles, use wings to resist torsion forces. Provide drilled pier designs with a factor of safety of at least 2.0 for torsion.

For drilled pier sign foundations supporting upright trusses, use dual drilled piers connected with a grade beam having a moment of inertia approximately equal to that of either pier. The Broms' method is acceptable to analyze drilled piers with grade beams instead of LPILE. Use a safety factor of at least 3.5 for the Broms' design method in accordance with C13.6.1.1 of the *AASHTO Standard Specifications for Structural Supports for Highway Signs, Luminaires and Traffic Signals*.

Submit boring logs, if any, working drawings and design calculations for acceptance in accordance with Article 105-2 of the *2018 Standard Specifications*. Submit working drawings showing plan views, required foundation dimensions and elevations and typical sections with reinforcement, conduit and anchor rod assembly details. Include all boring logs, design calculations and LPILE output for sign foundation design submittals. Have sign foundations designed, detailed and sealed by an engineer licensed in the state of North Carolina.

Construction Methods

Construct footings, pedestals, drilled piers, grade beams and wings and install anchor rod assemblies for sign foundations in accordance with the *Foundations and Anchor Rod Assemblies for Metal Poles* provision.

Measurement and Payment

Overhead Footings will be measured and paid in cubic yards. Sign foundations will be measured as the cubic yards of foundation concrete for footings, pedestals, drilled piers, grade beams and wings shown on the accepted submittals. The contract unit price for *Overhead Footings* will be full compensation for providing labor, tools, equipment and foundation materials, stabilizing or shoring excavations and supplying concrete, reinforcing steel, conduit, anchor rod assemblies and any incidentals necessary to construct sign foundations. Subsurface investigations required by the Engineer will be paid as extra work in accordance with Article 104-7 of the *2018 Standard Specifications*.

TIP # R-5734A

SN-3

Macon County

Payment will be made under:

Pay Item
Overhead Footings

Pay Unit
Cubic Yard

TIP # R-5734A

SN- 4

Macon County



DocuSigned by:
Betsy L. Watson
 35E67BB34F8743F...

10/22/2018

DISPOSAL OF SIGN SYSTEM ON SPAN WIRE

The work covered by this special provision consists of removal and disposal of the system for overhead signs mounted on span wire. The system includes the signs, span wire, poles, and all associated hardware necessary for the span wire sign system.

All material shall be removed and disposed according to the State and Local codes, regulations, and ordinances and shall be in accordance with the Section 907 of the NCDOT Standard Specifications for Roads and Structures.

Compensation:

Disposal of the system as described above shall be paid for at the unit price for each span wire sign system.

Payment will be made under:

Disposal of Sign System on Span Wire Each

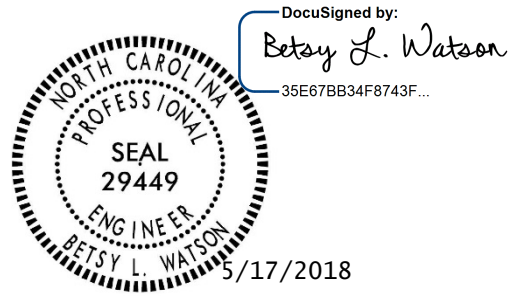

IN LANE ROUTE SHIELDS:

(01/31/2018)

Description

This work shall consist of applying NCDOT approved In Lane Route Shields in accordance with Section 1205 of the *2018 Standard Specifications*.

Application

Install Heated-In-Place Thermoplastic In Lane Route Shields that are capable of adhering to both asphalt and concrete pavements. Installation shall be in accordance with the manufacturer's specifications.

Measurement and Payment

In Lane Route Shields will be measured and paid for in units of each that have been satisfactorily placed and accepted.

Add the following pay item:

Pay Item

In Lane Route Shields

Pay Unit

Each

Project: R-5734A

UC-1

County: Macon

PROJECT SPECIAL PROVISIONS
Utility Construction



Stantec Consulting Services Inc.
301 N. Main St., Suite 2452
Winston-Salem, NC 27101
Firm License No.:

6/5/2018

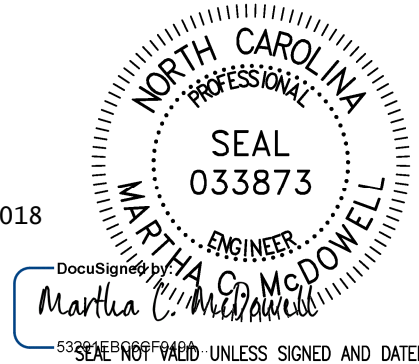

SEAL NOT VALID UNLESS SIGNED AND DATED

DOCUMENT NOT CONSIDERED FINAL
UNLESS ALL SIGNATURES COMPLETED

Utility Owner:

Town of Franklin
95 E. Main St.
Franklin, NC 28734

Revise the 2018 Standard Specifications as follows:

Page 10-61, Sub-article 1034-1 Clay Pipe, strike this sub-article in its entirety. No vitrified clay pipe shall be included in this project.

Page 10-61, Sub-article 1034-2 Plastic Pipe, (B) PVC Force Main Sewer Pipe, add the following sentences:

PVC force main piping shall have a green exterior color. Under no circumstances shall pipe with a blue exterior color be accepted.

Where PVC pipe is installed in iron pipe size (IPS), an IPS gasket shall be furnished with each fitting to insure compatibility.

Page 10-61, Sub-article 1034-3 Concrete Sewer Pipe, strike this sub-article in its entirety. No concrete sewer pipe shall be included in this project.

Page 10-61, Sub-article 1034-4 Ductile Iron Pipe, (A) Gravity Flow Sewer Pipe, add the following sentences to Sub-article (A).

Pipe Lining:

The standard of quality is Protecto 401™ Ceramic Epoxy. The material shall be an amine cured novolac epoxy containing at least 20% by volume of ceramic quartz pigment. Any request for substitution must be accompanied by a successful

Project: R-5734A

UC-2

County: Macon

history of lining pipe and fittings for sewer service, a test report verifying the following properties, and a certification of the test results.

After surface preparation and within 12 hours of surface preparation, the interior of the pipe shall receive 40 mils nominal dry film thickness. No lining shall take place when the substrate or ambient temperature is below 40°F. The surface also must be dry and dust free.

Pipe Handling:

Lined pipe and fittings must be handled only from the outside of the pipe and fittings. No forks, chains, straps, hooks, etc. shall be placed inside the pipe and fittings for lifting, positioning, or laying. The pipe shall not be dropped or unloaded by rolling. Care should be taken not to let the pipe strike sharp objects while swinging or being off loaded

Page 10-62, Sub-article 1036-1 General, add the following sentences:

All materials in contact with potable water shall be in conformance with Section 1417 of the Safe Drinking Water Act.

All permanent PVC water lines to be incorporated into the project and to be taken over by the Town of Franklin shall be installed with a copper tracer wire.

Page 10-63, Sub-article 1036-6 Fire Hydrants, replace with the following:

Fire hydrants shall comply with all of the applicable requirements of the AWWA C-502, latest revision, for dry-barrel fire hydrants and with these specifications. Hydrants shall be of the traffic model type incorporating a break-away flange arrangement which will permit the upper section of the hydrant barrel to separate from the lower section upon impact. Each hydrant shall include an automatic system designed to lubricate the entire length of the threaded part of the valve stem each time the hydrant is operated. It shall be further equipped with "O"-ring seals to ensure that threads on the valve stem do not come into contact with water at any time.

Hydrants shall open counterclockwise with a compression base valve opening against and closing with pressure and be capable of withstanding 250 psi working pressures and 500 psi hydrostatic test pressures, unless otherwise specified. The pentagonal operating nut shall be 1-1/2" from the point to the flat. Hydrants shall be equipped with one (1) 4-1/2" pumper nozzle and two (2) 2-1/2" hose nozzles, all with National Standard Threads per Appendix A of AWWA C-502, and chained nozzle caps. Nozzles shall be reverse threaded into the fire hydrant barrel.

Unless otherwise indicated on the plans approved by the Town, all hydrants shall have 6" mechanical joint bottom connections. For hydrants connected to 6" water mains, the hydrant shall have a 4½" main valve opening. For hydrants connected to water mains 8" and larger, the hydrant shall have a 5¼" main valve opening. The hydrant main valve shall be of the full compression design, opening against and closing with pressure. The valve

Project: R-5734A

UC-3

County: Macon

seat ring shall thread into a bronze sub-seat, and all gaskets sealing the seat ring shall be a bronze-to-bronze surface.

All iron parts within fire hydrants shall be ductile iron.

The bury length (distance from ground line to insert of the hydrant inlet) shall be 4'-0" unless ground conditions shown on the Town approved plans warrant a deeper bury.

Drain valves shall be all bronze and allow complete draining of all residual water from the hydrant barrel.

All bolting and fasteners below ground shall be stainless steel.

The operating machine shall utilize two (2) "O"-ring seals between the revolving nut and bronze-sheathed upper section of the valve rod. The top of the rod shall also be fitted with a travel stop nut to limit downward travel of the rod. All-weather grease shall be used to provide permanent lubrication. A thermoplastic thrust washer shall be used to reduce friction in the thrust collar while opening the hydrant.

The hydrant inlet shall be mechanical joint. Joint restraint shall be accomplished for mechanical joint by use of mechanical joint gripper glands or $\frac{3}{4}$ "Ø galvanized threaded rods.

Following installation and testing all hydrants shall be painted with two (2) 6-mil coats of epoxy paint.

Summary Public Fire Hydrants:

- Yellow Paint for the "Body" of the hydrant
- Hydrant connections shall be National Standard Thread
- Black "Out of Use" disk (no bag) installed immediately upon fire hydrant installation
- 1 to 4 inches from bottom of breakaway flange to final

grade

Hydrants accepted by the Town of Franklin are as follows:

- Super Centurion 250, A-423 5 $\frac{1}{4}$ " manufactured by Mueller Company

Page 10-63, Sub-article 1036-7 (A), replace the first sentence with the following:

All gate valves shall be designed for a minimum working pressure of 200 psi unless otherwise specified.

Use iron body gate valves which conform to ANSI/AWWA C509 for resilient seat-type valves.

Page 10-63, Sub-article 1036-7 (C), add the following sentence:

All air release valves shall be Golden Anderson Fig. 910 or approved equivalent.

Project: R-5734A

UC-4

County: Macon

Page 15-1, Sub-article 1500-2 Cooperation with the Utility Owner, paragraph 2, add the following sentence:

The water utility owner is the Town of Franklin. The Town Engineer is Nathanael Moore and he can be reached at 336-524-2516. The Public Works Director is Jay Gibson, Public Works Director and he can be reached by phone at (828) 369-5228.

Page 15-2, Sub-article 1500-9, paragraph 2, sentence 2, replace in its entirety with the following sentences:

Interruptions in water service for all distribution system mains shall be limited to a maximum of 4 hours unless otherwise specifically approved by the Town of Franklin City Engineer. Interruptions in water service for all water services shall be limited to a maximum of 6 hours unless otherwise specifically approved by the Town of Franklin City Engineer.

Page 15-2, Sub-article 1500-9, add the following paragraphs:

All existing water and sewer services which are to be modified, reconnected, relocated, or removed shall be done to the satisfaction of the utility owner's representatives. The Contractor shall coordinate field review by the utility owner's representatives through the Town of Franklin's City Engineer.

All proposed water and sewer services which are to be installed shall be done to the satisfaction of the utility owner's representatives. The Contractor shall coordinate field review by the utility owner's representatives through the Town of Franklin's City Engineer.

Page 15-5, Sub-article 1510-2, Materials, add the following sentences:

All water lines that will belong to the of Town of Franklin that are 6" in diameter or larger shall be ductile iron PC 350.

Page 15-8, Sub-article 1515-3 Construction Methods (A), add the following paragraph:

Air release valves installed directly to water main shall be installed in 4' manholes sections. Manhole shall be set plumb and on a firm foundation. Each joint between sections and all wall openings shall be sealed inside and out with a 2:1 sand-cement mortar and made watertight.

Page 15-8, Sub-article 1515-3 Construction Methods (B), add the following paragraph:

All water meters incorporated into the project shall conform to the Town of Franklin Standards and shall be purchased from the Town of Franklin's meter inventory and installed by the Contractor.

Project: R-5734A

UC-5

County: Macon

Page 15-8, Sub-article 1515-3 (B) Meters, add the following to line 29:

Meter box shall be standard rectangular meter box design. Meter box shall be sized to accept a 5/8" water meter, specifically MB-6 or Dexor Plastics DX1015-24 CIR. Meter box and associated installations shall be in accordance with Town of Franklin Standard Details W-14.

Page 15-10, Sub-article 1520-2, Materials, add the following paragraph:

All sanitary sewer cleanouts shall be provided and installed as specified in the plans and shall be either Sch 40 PVC or PC 350 ductile iron pipe.

Page 15-11, Sub-article 1520-3, replace Line 2 with the following:

No vitrified clay pipe material shall be included in this project.

Page 15-11, Sub-article 1520-3(A)(2) Testing, replace in entirety with the following:

Testing for sanitary sewer pipe and appurtenances shall be in accordance with Town of Franklin Specifications Section 02730, Part 3.02.

Page 15-15, Sub-article 1525-3 Construction Methods (A), Cast-In-Place Concrete, Brick and Block Masonry, Line 9, delete the second and last sentences in entirety:

No brick or block masonry manholes shall be included in this project.

Page 15-16, Sub-article 1530-3 Construction Methods (B), Abandoning Manholes, Line 5, replace with the following:

Abandon utility manholes in the construction limits by removing the top of the manhole to the manhole spring line or to an elevation of 3 feet below the roadway subgrade, whichever is greater and filling the manhole barrel with approved material.

17BP.14.R.154

UC-6

Macon County

UTILITY CONSTRUCTION:

Prepared by:
 STV Engineers, Inc.
 900 West Trade Street, Suite 715
 Charlotte, NC 28202
 704/372-1885
 NC License Number F-0991

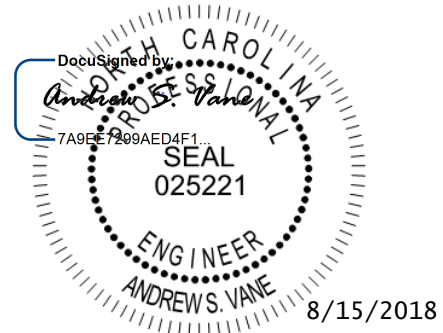

Document not considered Final
 Unless All Signatures Completed

PROJECT SPECIAL PROVISIONS

Unless otherwise indicated in these special provisions, all materials and requirements for proposed water and sewer lines shall at a minimum meet the standards and requirements outlined in the NCDOT Standard Specifications.

CONNECTIONS TO EXISTING SEWERS

Tie-ins to existing activated sewer lines will be allowed when proper precautions are taken to protect the existing main. Tie-ins to existing inactivated sewer lines not installed under the same contract will not be allowed without written approval from all parties involved (Owner, contractors, contract holders, etc.). The Contractor will be required to install watertight masonry plugs in the proposed pipeline at the existing manhole and at the first proposed manhole until all construction is completed and testing begun.

Stub-outs between new manholes and existing sewer mains shall match the direction and slope of the existing sewer main.

Temporary Watertight Plugs: The Contractor shall install temporary watertight plugs in the proposed sewer line at any manhole that is incomplete, at the open end of the pipeline prior to leaving the job site daily and elsewhere as dictated by good engineering and construction practices. All installed pipe shall be backfilled or otherwise securely tied down to prevent flotation in the event water enters or rises in the trench. The plugs as installed shall prevent infiltration or the introduction of any foreign material into either the existing or proposed systems. The Contractor shall at his own expense flush, or otherwise cause the line (and manholes) to be cleaned out without any discharge into the existing system.

Upon completion of all construction, the Contractor will be responsible for the complete removal of all watertight plugs, in the sequence necessary to allow testing and subsequent activation, all under the direction of the Engineer.

Scheduling: When the flow of an existing sewer must be interrupted and/or bypassed, the Contractor shall, before beginning any construction, submit a work schedule which will minimize the interruption and/or bypassing of wastewater flow during construction. This schedule must be approved by the Department and may require night, holiday, and/or weekend work.

PAY ITEM DESCRIPTIONS FOR WATER LINE AND SANITARY SEWER CONSTRUCTION

The bid for each pay item shall include the cost of all materials, equipment, labor and all else required to complete that pay item as specified.

Materials shall be new, in good condition and free from defects.

Materials, equipment, labor, permits, fees or incidentals required to complete Work for which there is no clearly described pay item shall have their cost incorporated into the pay items listed below. No separate payment for this Work will be made.

Payment will be made according to the unit price or lump sum bid in the Proposal.

Abbreviations used in the Plans, Specifications, and Bid Form include, but are not limited to:

1. LS = lump sum
2. EA = each
3. LF = linear foot
4. VF = vertical foot
5. CY = cubic yard
6. LBS = pounds
7. SF = square foot
8. TN = ton

TEMPORARY SANITARY SEWER BYPASS PUMPING

1.0 DESCRIPTION

This item, Temporary Sanitary Sewer Bypass Pumping, shall include the cost of all materials, equipment, labor and all else required to complete this pay item as specified.

When pumping is required, an identical standby pump shall be on site in the event of failure of the primary pump. If, at any time during construction, effluent from the existing sewer is not fully contained by the bypass system, gravity service will be restored by a temporary tie to the new construction and work shall be suspended until the problem is resolved to the satisfaction of the Engineer. The Contractor shall be responsible for any fines levied as a result of effluent reaching the creek. The Contractor will be required to verify his method of handling sewer flows during construction by pumping at peak flows for 1 hour as approved by the Department.

This is a lump sum pay item. It includes everything associated with the installation, operation, maintenance, and removal of a temporary sanitary sewer bypass pumping operation. There are no separate pay items associated with this Work. The Work, in its entirety, is payable only through this lump sum pay item.

2.0 MATERIALS AND METHODS

Contractor shall maintain continuous sanitary service to all users, except when a planned outage with a specified duration has been preapproved by the Engineer.

The Contractor shall not be permitted to plug or sever sewer lines without a fully functional and approved bypass pumping operation.

The number and size of pumps, pipes, and connections utilized in the bypass pumping operation shall be designed, scheduled, and installed such that if the largest pump is taken out of service, the remaining pumps can maintain bypass flows without a surcharge that results in an overflow of sewage.

Prior to existing sanitary sewer flows being bypassed, the Contractor shall develop a temporary sanitary sewer bypass pumping operation plan. Contractor's proposed temporary sanitary sewer bypass pumping operation shall be designed and sealed by a North Carolina Professional Engineer.

Contractor shall submit the temporary sanitary sewer bypass pumping operation plan to the Department for review. Include the following items:

1. Sealed 11" x 17" sheets for plan view, prepared and sealed by a Registered North Carolina Professional Engineer
2. Scale: 1" = 40'
3. Show location, size and number of pumps
4. Show above ground temporary force main and buried temporary force main
5. Label force main size, length, material type and thickness
6. Show phasing and duration for which force main and pumps will remain in service
7. Show location of signage
8. Show all associated traffic and pedestrian control

Contractor is responsible for determining peak flows, including wet weather flows, to be handled by the temporary sanitary sewer bypass pumping operation. This shall be accomplished by coordinating with the Utility Owner.

Contractor shall be responsible for monitoring the bypass pumping operation at all times it is operational. 'Monitoring' shall be defined as the continuous presence of the Contractor's qualified personnel at the site of the bypass pumping operation, until all sewage flows are conveyed by the new, permanent, activated sanitary sewer system.

The Contractor shall make all repairs and provide additional support services and protection when the temporary sanitary sewer bypass pumping operation has been damaged by vandalism or other events.

The Contractor shall immediately notify the Utility Owner and the Department in the event a surcharge occurs that results in an overflow of sewage.

The Contractor shall be responsible for paying fines and cleanup operations associated with overflow violations attributed to the bypass pumping operation at no additional cost to the Department.

17BP.14.R.154

UC-9

Macon County

All related asphalt and concrete work associated with the temporary sanitary sewer bypass pumping operation, including trenched force main, temporary surfaces, steel plates, saw cutting, removal and disposal of asphalt and concrete, and installation of temporary paving if required are included in this pay item.

Ingress and egress to properties shall be maintained at all times. Pedestrian and vehicular traffic shall be maintained at all times.

Precautions shall be taken to ensure the temporary sanitary sewer bypass pumping operation does not damage public or private properties. In the event damage occurs, Contractor shall make provisions to correct such damage at no additional cost to the Department.

The Contractor shall respond, with personnel and equipment, within the following time limits to complaints from the Utility Owner.

1. 15 - minutes for weekday regular hour complaints
2. 1 - hour for night/weekend complaints

3.0 MEASUREMENT

Temporary Sanitary Sewer Bypass Pumping is a lump sum item that will be measured by the complete installation and acceptance of the Temporary Sanitary Sewer Bypass Pumping as described above.

4.0 PAYMENT

Temporary Sanitary Sewer Bypass Pumping Operation, measured as provided above, will be paid for at the lump sum Contract unit price for "Temporary Sanitary Sewer Bypass Pumping." Such payment will be full compensation for all Work covered by this Project Special Provision.

Payment will be made under:

TEMPORARY SANITARY SEWER BYPASS PUMPINGLS

PROJECT SPECIAL PROVISIONS

Utilities by Others

 <p>Michael Baker INTERNATIONAL</p>	<p>Michael Baker Engineering, Inc. 8000 Regency Parkway, Suite 600 Cary, North Carolina 27518 Phone: 919-463-5488 Fax: 919-463-5490</p>
---	--

General:

The following utility companies have facilities that will be in conflict with the construction of this project:

- A) Duke Energy – Power (Distribution)
- B) Frontier – Communications
- C) Balsam West Fibernet – Communications
- D) Morris Broadband – Communications
- E) Toccoa Natural Gas - Gas

The conflicting facilities of these concerns will be adjusted prior to the date of availability, unless otherwise noted and are therefore listed in these special provisions for the benefit of the Contractor. All utility work listed herein will be done by the utility owners. All utilities are shown on the plans from the best available information.

The Contractor’s attention is directed to Article 105-8 of the 2018 Standard Specifications.

Utilities Requiring Adjustment:

Utility relocations are shown on the Utilities by Others Plans.

- A) Duke Energy – Power (Distribution)
 - 1) Duke Energy will install new utility poles and aerial lines within the project limits.
 - 2) Duke Energy’s relocation work will be completed by February 8, 2019.
 - 3) Contact person for Duke Energy is Ovidiu Babici at (864) 510-3779 or ovidiu.babici@duke-energy.com.
- B) Frontier – Communications
 - 1) Frontier will follow Duke Energy’s pole line, install buried cables and abandon existing facilities within the project limits.
 - 2) Frontier’s aerial relocation work will be completed by April 5, 2019.

PROJECT SPECIAL PROVISIONS

Utilities by Others

- 3) Frontier will need four weeks' notice and ten weeks to complete their buried relocations following rough grade, right of center, from beginning of project limits to Station -L- 27+00.
 - 4) Contact person for Frontier is Tina Rutherford at (828) 631-4058 or tina.rutherford@ftr.com.
- C) Balsam West Fibernet – Communications
- 1) Balsam West Fibernet will install buried cables and abandon facilities within the project limits.
 - 2) Balsam West Fibernet will need four weeks' notice and ten weeks to complete their buried relocation following rough grade, right of center-
 - 3) Contact person for Balsam West Fibernet is Danny Haynes at (828) 399-9760 or dhaines@balsamwest.net.
- D) Morris Broadband – Communications
- 1) Morris Broadband will follow Duke Energy's pole line within the project limits.
 - 2) Morris Broadband's relocation work will be completed by 3/15/19.
 - 3) Contact person for Morris Broadband is Chris McCall at (828) 697-3600 Ext. 646 or chris.mccall@morris.com.
- E) Toccoa Natural Gas – Gas
- 1) Toccoa Natural Gas has an eight-inch steel high pressure line that will remain in place during sewer and drainage construction at approximate Station -L- 15+00, 29+00 and 34+00. Toccoa Natural Gas requests seven days' notice prior to construction and shall be on site while working near their facilities.
 - 2) Toccoa Natural Gas will lower their eight-inch steel high pressure gas at approximate Station -L- 17+00 and 33+00.
 - 3) Toccoa Natural Gas's facilities will be relocated from approximate Station -L- 44+00 through the end of the project limits.
 - 4) Toccoa Natural Gas's relocation work will be completed by February 15, 2019.
 - 5) Contact person for Toccoa Natural Gas is Rance Fleming at (828) 349-1222 or rfleming@cityoftoccoa.com.

PROJECT SPECIAL PROVISIONS**UTILITIES BY OTHERS:****Description**

The following utility companies have facilities that will be in conflict with the construction of this project:

- A. Duke Energy
- B. Frontier Communications
- C. Morris Broadband

The conflicting facilities will be adjusted prior to the date of availability and are therefore listed in these special provisions for the benefit of the Contractor. All utility work listed herein will be done by the utility owner. All utilities are shown on the plans from the best available information.

The Contractor's attention is directed to Article 105.8 of the *Standard Specifications*.

Utilities Requiring Adjustment:**A. Duke Energy – Power Distribution**

- (a) Duke Energy owns aerial power transmission and distribution facilities to the east and west of -L- (Belden Circle. There are no conflicts anticipated with these aerial lines.

- (b) Contact person for Duke Energy is:

Jimmy Voris
957 Spartanburg Highway
Hendersonville, NC 28792
(828) 698-2043- Office
(828) 606-7808- Cell
james.voris@duke-energy.com

B. Frontier Communications

- (a) Frontier owns aerial and buried facilities located along the western side of Belden Circle (-L-). These facilities parallel and cross the bridge and are in conflict with construction. Frontier will relocate their facilities by setting three new permanent joint use poles at -L- Sta. 14+51 35' Lt., -L- Sta. 15+73 45' Lt., and -L- Sta. 16+45 20' Lt. Frontier will also set a new telephone pedestal at -L- Sta. 14+15 28' Lt.

(b) Contact person for Frontier Communications is:

Tina Rutherford
84 Allen Street
Sylva, NC 28779
(828) 631-4058- Office
(828) 421-2475- Cell
tina.rutherford@ftr.com

C. Morris Broadband - Communications

(a) Morris Broadband owns aerial facilities located along the western side of Belden Circle (-L-). These facilities parallel and cross the bridge and are in conflict with construction. Morris Broadband will relocate their facilities to the new permanent joint use poles being set by Frontier.

(c) Contact person for Morris Broadband is:

Doug King
719 South Grove Street
Hendersonville, NC 28792
(828) 697-3600- Office
(828) 772-1167- Cell
doug.king@morris.com

**Project Special Provisions
Erosion Control**

STABILIZATION REQUIREMENTS:

(3-11-2016)

Stabilization for this project shall comply with the time frame guidelines as specified by the NCG-010000 general construction permit effective August 1, 2016 issued by the North Carolina Department of Environmental Quality Division of Water Resources. Temporary or permanent ground cover stabilization shall occur within 7 calendar days from the last land-disturbing activity, with the following exceptions in which temporary or permanent ground cover shall be provided in 14 calendar days from the last land-disturbing activity:

- Slopes between 2:1 and 3:1, with a slope length of 10 ft. or less
- Slopes 3:1 or flatter, with a slope of length of 50 ft. or less
- Slopes 4:1 or flatter

The stabilization timeframe for High Quality Water (HQW) Zones shall be 7 calendar days with no exceptions for slope grades or lengths. High Quality Water Zones (HQW) Zones are defined by North Carolina Administrative Code 15A NCAC 04A.0105 (25). Temporary and permanent ground cover stabilization shall be achieved in accordance with the provisions in this contract and as directed.

SEEDING AND MULCHING:

(WestEd)

The kinds of seed and fertilizer, and the rates of application of seed, fertilizer, and limestone, shall be as stated below. During periods of overlapping dates, the kind of seed to be used shall be determined. All rates are in pounds per acre.

Shoulder and Median Areas

August 1 - June 1

20# Kentucky Bluegrass
75# Hard Fescue
25# Rye Grain
500# Fertilizer
4000# Limestone

May 1 - September 1

20# Kentucky Bluegrass
75# Hard Fescue
10# German or Browntop Millet
500# Fertilizer
4000# Limestone

Areas Beyond the Mowing Pattern, Waste and Borrow Areas:

August 1 - June 1

100# Tall Fescue
15# Kentucky Bluegrass
30# Hard Fescue
25# Rye Grain
500# Fertilizer
4000# Limestone

May 1 - September 1

100# Tall Fescue
15# Kentucky Bluegrass
30# Hard Fescue
10# German or Browntop Millet
500# Fertilizer
4000# Limestone

Approved Tall Fescue Cultivars

06 Dust	Escalade	Justice	Serengeti
2 nd Millennium	Essential	Kalahari	Shelby
3 rd Millennium	Evergreen 2	Kitty Hawk 2000	Sheridan
Apache III	Falcon IV	Legitimate	Signia
Avenger	Falcon NG	Lexington	Silver Hawk
Barlexas	Falcon V	LSD	Sliverstar
Barlexas II	Faith	Magellan	Shenandoah Elite
Bar Fa	Fat Cat	Matador	Sidewinder
Barrera	Festnova	Millennium SRP	Skyline
Barrington	Fidelity	Monet	Solara
Barrobusto	Finelawn Elite	Mustang 4	Southern Choice II
Barvado	Finelawn Xpress	Ninja 2	Speedway
Biltmore	Finesse II	Ol' Glory	Spyder LS
Bingo	Firebird	Olympic Gold	Sunset Gold
Bizem	Firecracker LS	Padre	Taccoa
Blackwatch	Firenza	Patagonia	Tanzania
Blade Runner II	Five Point	Pedigree	Trio
Bonsai	Focus	Picasso	Tahoe II
Braveheart	Forte	Piedmont	Talladega
Bravo	Garrison	Plantation	Tarheel
Bullseye	Gazelle II	Proseeds 5301	Terrano
Cannavaro	Gold Medallion	Prospect	Titan ltd
Catalyst	Grande 3	Pure Gold	Titanium LS
Cayenne	Greenbrooks	Quest	Tracer
Cessane Rz	Greenkeeper	Raptor II	Traverse SRP
Chipper	Gremlin	Rebel Exeda	Tulsa Time
Cochise IV	Greystone	Rebel Sentry	Turbo
Constitution	Guardian 21	Rebel IV	Turbo RZ
Corgi	Guardian 41	Regiment II	Tuxedo RZ
Corona	Hemi	Regenerate	Ultimate
Coyote	Honky Tonk	Rendition	Venture
Darlington	Hot Rod	Rhambler 2 SRP	Umbrella
Davinci	Hunter	Rembrandt	Van Gogh
Desire	Inferno	Reunion	Watchdog
Dominion	Innovator	Riverside	Wolfpack II
Dynamic	Integrity	RNP	Xtremegreen
Dynasty	Jaguar 3	Rocket	
Endeavor	Jamboree	Scorpion	

Approved Kentucky Bluegrass Cultivars:

4-Season	Blue Velvet	Gladstone	Quantum Leap
Alexa II	Blueberry	Granite	Rambo
America	Boomerang	Hampton	Rhapsody
Apollo	Brilliant	Harmonie	Rhythm
Arcadia	Cabernet	Impact	Rita
Aries	Champagne	Jefferson	Royce
Armada	Champlain	Juliet	Rubicon
Arrow	Chicago II	Jump Start	Rugby II
Arrowhead	Corsair	Keeneland	Shiraz
Aura	Courtyard	Langara	Showcase
Avid	Delight	Liberator	Skye
Award	Diva	Madison	Solar Eclipse
Awesome	Dynamo	Mercury	Sonoma
Bandera	Eagleton	Midnight	Sorbonne
Barduke	Emblem	Midnight II	Starburst
Barnique	Empire	Moon Shadow	Sudden Impact
Baroness	Envicta	Moonlight SLT	Total Eclipse
Barrister	Everest	Mystere	Touche
Barvette HGT	Everglade	Nu Destiny	Tsunami
Bedazzled	Excursion	NuChicago	Unique
Belissimo	Freedom II	NuGlade	Valor
Bewitched	Freedom III	Odyssey	Voyager II
Beyond	Front Page	Perfection	Washington
Blacksburg II	Futurity	Pinot	Zinfandel
Blackstone	Gaelic	Princeton 105	
Blue Note	Ginney II	Prosperity	

Approved Hard Fescue Cultivars:

Aurora II	Eureka II	Oxford	Scaldis II
Aurora Gold	Firefly	Reliant II	Spartan II
Berkshire	Granite	Reliant IV	Stonehenge
Bighorn GT	Heron	Rescue 911	
Chariot	Nordic	Rhino	

On cut and fill slopes 2:1 or steeper add 20# Sericea Lespedeza and 15# Crown Vetch January 1 - December 31.

The Crown Vetch Seed should be double inoculated if applied with a hand seeder. Four times the normal rate of inoculant should be used if applied with a hydroseeder. If a fertilizer-seed slurry is used, the required limestone should also be included to prevent fertilizer acidity from killing the inoculant bacteria. Caution should be used to keep the inoculant below 80° F to prevent harm to the bacteria. The rates and grades of fertilizer and limestone shall be the same as specified for *Seeding and Mulching*.

Fertilizer shall be 10-20-20 analysis. A different analysis of fertilizer may be used provided the 1-2-2 ratio is maintained and the rate of application adjusted to provide the same amount of plant food as a 10-20-20 analysis and as directed.

Native Grass Seeding And Mulching

(West)

Native Grass Seeding and Mulching shall be performed on the disturbed areas of wetlands and riparian areas, and adjacent to Stream Relocation and/or trout stream construction within a 50 foot zone on both sides of the stream or depression, measured from top of stream bank or center of depression. The stream bank of the stream relocation shall be seeded by a method that does not alter the typical cross section of the stream bank. Native Grass Seeding and Mulching shall also be performed in the permanent soil reinforcement mat section of preformed scour holes, and in other areas as directed.

The kinds of seed and fertilizer, and the rates of application of seed, fertilizer, and limestone, shall be as stated below. During periods of overlapping dates, the kind of seed to be used shall be determined. All rates are in pounds per acre.

August 1 - June 1

- 18# Creeping Red Fescue
- 8# Big Bluestem
- 6# Indiangrass
- 4# Switchgrass
- 35# Rye Grain
- 500# Fertilizer
- 4000# Limestone

May 1 – September 1

- 18# Creeping Red Fescue
- 8# Big Bluestem
- 6# Indiangrass
- 4# Switchgrass
- 25# German or Browntop Millet
- 500# Fertilizer
- 4000# Limestone

Approved Creeping Red Fescue Cultivars:

- Aberdeen
- Boreal
- Epic
- Cindy Lou

Fertilizer shall be 10-20-20 analysis. A different analysis of fertilizer may be used provided the 1-2-2 ratio is maintained and the rate of application adjusted to provide the same amount of plant food as a 10-20-20 analysis and as directed.

Native Grass Seeding and Mulching shall be performed in accordance with Section 1660 of the *Standard Specifications* and vegetative cover sufficient to restrain erosion shall be installed immediately following grade establishment.

Measurement and Payment

Native Grass *Seeding and Mulching* will be measured and paid for in accordance with Article 1660-8 of the *Standard Specifications*.

TEMPORARY SEEDING:

Fertilizer shall be the same analysis as specified for *Seeding and Mulching* and applied at the rate of 400 pounds and seeded at the rate of 50 pounds per acre. German Millet, or Browntop Millet shall be used in summer months and rye grain during the remainder of the year. The Engineer will determine the exact dates for using each kind of seed.

FERTILIZER TOPDRESSING:

Fertilizer used for topdressing shall be 16-8-8 grade and shall be applied at the rate of 500 pounds per acre. A different analysis of fertilizer may be used provided the 2-1-1 ratio is maintained and the rate of application adjusted to provide the same amount of plant food as 16-8-8 analysis and as directed.

SUPPLEMENTAL SEEDING:

The kinds of seed and proportions shall be the same as specified for *Seeding and Mulching*, and the rate of application may vary from 25# to 75# per acre. The actual rate per acre will be determined prior to the time of topdressing and the Contractor will be notified in writing of the rate per acre, total quantity needed, and areas on which to apply the supplemental seed. Minimum tillage equipment, consisting of a sod seeder shall be used for incorporating seed into the soil as to prevent disturbance of existing vegetation. A clodbuster (ball and chain) may be used where degree of slope prevents the use of a sod seeder.

MOWING:

The minimum mowing height on this project shall be six inches.

LAWN TYPE APPEARANCE:

All areas adjacent to lawns must be hand finished as directed to give a lawn type appearance. Remove all trash, debris, and stones $\frac{3}{4}$ " and larger in diameter or other obstructions that could interfere with providing a smooth lawn type appearance. These areas shall be reseeded to match their original vegetative conditions, unless directed otherwise by the Field Operations Engineer.

REFORESTATION:**Description**

Reforestation will be planted within interchanges and along the outside borders of the road, and in other areas as directed. *Reforestation* is not shown on the plan sheets. See the Reforestation Detail Sheet.

All non-maintained riparian buffers impacted by the placement of temporary fill or clearing activities shall be restored to the preconstruction contours and revegetated with native woody species.

The entire *Reforestation* operation shall comply with the requirements of Section 1670 of the *Standard Specifications*.

Materials

Reforestation shall be bare root seedlings 12"-18" tall.

Construction Methods

Reforestation shall be planted as soon as practical following permanent *Seeding and Mulching*. The seedlings shall be planted in a 16-foot wide swath adjacent to mowing pattern line, or as directed.

Root dip: The roots of reforestation seedlings shall be coated with a slurry of water, and either a fine clay (kaolin) or a superabsorbent that is designated as a bare root dip. The type, mixture ratio, method of application, and the time of application shall be submitted to the Engineer for approval.

With the approval of the Engineer, seedlings may be coated before delivery to the job or at the time of planting, but at no time shall the roots of the seedlings be allowed to dry out. The roots shall be moistened immediately prior to planting.

Seasonal Limitations: *Reforestation* shall be planted from November 15 through March 15.

Measurement and Payment

Reforestation will be measured and paid for in accordance with Article 1670-17 of the *Standard Specifications*.

RESPONSE FOR EROSION CONTROL:

Description

Furnish the labor, materials, tools and equipment necessary to move personnel, equipment, and supplies to the project necessary for the pursuit of any or all of the following work as shown herein, by an approved subcontractor.

Section	Erosion Control Item	Unit
1605	Temporary Silt Fence	LF
1606	Special Sediment Control Fence	LF/TON
1615	Temporary Mulching	ACR
1620	Seed - Temporary Seeding	LB
1620	Fertilizer - Temporary Seeding	TN
1631	Matting for Erosion Control	SY

SP	Coir Fiber Mat	SY
1640	Coir Fiber Baffles	LF
SP	Permanent Soil Reinforcement Mat	SY
1660	Seeding and Mulching	ACR
1661	Seed - Repair Seeding	LB
1661	Fertilizer - Repair Seeding	TON
1662	Seed - Supplemental Seeding	LB
1665	Fertilizer Topdressing	TON
SP	Safety/Highly Visible Fencing	LF
SP	Response for Erosion Control	EA

Construction Methods

Provide an approved subcontractor who performs an erosion control action as described in the NPDES Inspection Form SPPP30. Each erosion control action may include one or more of the above work items.

Measurement and Payment

Response for Erosion Control will be measured and paid for by counting the actual number of times the subcontractor moves onto the project, including borrow and waste sites, and satisfactorily completes an erosion control action described in Form 1675. The provisions of Article 104-5 of the *Standard Specifications* will not apply to this item of work.

Payment will be made under:

Pay Item

Response for Erosion Control

Pay Unit

Each

ENVIRONMENTALLY SENSITIVE AREAS:

Description

This project is located in an *Environmentally Sensitive Area*. This designation requires special procedures to be used for clearing and grubbing, temporary stream crossings, and grading operations within the Environmentally Sensitive Areas identified on the plans and as designated by the Engineer. This also requires special procedures to be used for seeding and mulching and staged seeding within the project.

The Environmentally Sensitive Area shall be defined as a 50-foot buffer zone on both sides of the stream or depression measured from top of streambank or center of depression.

Construction Methods

(A) Clearing and Grubbing

In areas identified as Environmentally Sensitive Areas, the Contractor may perform clearing operations, but not grubbing operations until immediately prior to beginning grading operations as described in Article 200-1 of the *Standard Specifications*. Only clearing operations (not grubbing) shall be allowed in this buffer zone until immediately prior to beginning grading operations. Erosion control devices shall be installed immediately following the clearing operation.

(B) Grading

Once grading operations begin in identified Environmentally Sensitive Areas, work shall progress in a continuous manner until complete. All construction within these areas shall progress in a continuous manner such that each phase is complete and areas are permanently stabilized prior to beginning of next phase. Failure on the part of the Contractor to complete any phase of construction in a continuous manner in Environmentally Sensitive Areas will be just cause for the Engineer to direct the suspension of work in accordance with Article 108-7 of the *Standard Specifications*.

(C) Temporary Stream Crossings

Any crossing of streams within the limits of this project shall be accomplished in accordance with the requirements of Subarticle 107-12 of the *Standard Specifications*.

(D) Seeding and Mulching

Seeding and mulching shall be performed in accordance with Section 1660 of the *Standard Specifications* and vegetative cover sufficient to restrain erosion shall be installed immediately following grade establishment.

Seeding and mulching shall be performed on the areas disturbed by construction immediately following final grade establishment. No appreciable time shall lapse into the contract time without stabilization of slopes, ditches and other areas within the Environmentally Sensitive Areas.

(E) Stage Seeding

The work covered by this section shall consist of the establishment of a vegetative cover on cut and fill slopes as grading progresses. Seeding and mulching shall be done in stages on cut and fill slopes that are greater than 20 feet in height measured along the slope, or greater than 2 acres in area. Each stage shall not exceed the limits stated above.

Additional payments will not be made for the requirements of this section, as the cost for this work shall be included in the contract unit prices for the work involved.

MINIMIZE REMOVAL OF VEGETATION:

The Contractor shall minimize removal of vegetation within project limits to the maximum extent practicable. Vegetation along stream banks and adjacent to other jurisdictional resources outside the construction limits shall only be removed upon approval of Engineer. No additional payment will be made for this minimization work.

STOCKPILE AREAS:

The Contractor shall install and maintain erosion control devices sufficient to contain sediment around any erodible material stockpile areas as directed.

ACCESS AND HAUL ROADS:

At the end of each working day, the Contractor shall install or re-establish temporary diversions or earth berms across access/haul roads to direct runoff into sediment devices. Silt fence sections that are temporarily removed shall be reinstalled across access/haul roads at the end of each working day.

WASTE AND BORROW SOURCES:

Payment for temporary erosion control measures, except those made necessary by the Contractor's own negligence or for his own convenience, will be paid for at the appropriate contract unit price for the devices or measures utilized in borrow sources and waste areas.

No additional payment will be made for erosion control devices or permanent seeding and mulching in any commercial borrow or waste pit. All erosion and sediment control practices that may be required on a commercial borrow or waste site will be done at the Contractor's expense.

All offsite Staging Areas, Borrow and Waste sites shall be in accordance with "Borrow and Waste Site Reclamation Procedures for Contracted Projects" located at:

http://www.ncdot.gov/doh/operations/dp_chief_eng/roadside/fieldops/downloads/Files/ContractedReclamationProcedures.pdf

All forms and documents referenced in the "Borrow and Waste Site Reclamation Procedures for Contracted Projects" shall be included with the reclamation plans for offsite staging areas, and borrow and waste sites.

TEMPORARY DIVERSION:

This work consists of installation, maintenance, and cleanout of *Temporary Diversions* in accordance with Section 1630 of the *Standard Specifications*. The quantity of excavation for installation and cleanout will be measured and paid for as *Silt Excavation* in accordance with Article 1630-3 of the *Standard Specifications*.

SAFETY FENCE AND JURISDICTIONAL FLAGGING:**Description**

Safety Fence shall consist of furnishing materials, installing and maintaining polyethylene or polypropylene fence along the outside riparian buffer, wetland, or water boundary, or other boundaries located within the construction corridor to mark the areas that have been approved to infringe within the buffer, wetland, endangered vegetation, culturally sensitive areas or water. The fence shall be installed prior to any land disturbing activities.

Interior boundaries for jurisdictional areas noted above shall be delineated by stakes and highly visible flagging.

Jurisdictional boundaries at staging areas, waste sites, or borrow pits, whether considered outside or interior boundaries shall be delineated by stakes and highly visible flagging.

Materials**(A) Safety Fencing**

Polyethylene or polypropylene fence shall be a highly visible preconstructed safety fence approved by the Engineer. The fence material shall have an ultraviolet coating.

Either wood posts or steel posts may be used. Wood posts shall be hardwood with a wedge or pencil tip at one end, and shall be at least 5 ft. in length with a minimum nominal 2" x 2" cross section. Steel posts shall be at least 5 ft. in length, and have a minimum weight of 0.85 lb/ft of length.

(B) Boundary Flagging

Wooden stakes shall be 4 feet in length with a minimum nominal 3/4" x 1-3/4" cross section. The flagging shall be at least 1" in width. The flagging material shall be vinyl and shall be orange in color and highly visible.

Construction Methods

No additional clearing and grubbing is anticipated for the installation of this fence. The fence shall be erected to conform to the general contour of the ground.

(A) Safety Fencing

Posts shall be set at a maximum spacing of 10 ft., maintained in a vertical position and hand set or set with a post driver. Posts shall be installed a minimum of 2 ft. into the ground. If hand set, all backfill material shall be thoroughly tamped. Wood posts may be sharpened to a dull point if power driven. Posts damaged by power driving shall be removed and replaced prior to final

acceptance. The tops of all wood posts shall be cut at a 30-degree angle. The wood posts may, at the option of the Contractor, be cut at this angle either before or after the posts are erected.

The fence geotextile shall be attached to the wood posts with one 2" galvanized wire staple across each cable or to the steel posts with wire or other acceptable means.

Place construction stakes to establish the location of the safety fence in accordance with Article 105-9 or Article 801-1 of the *Standard Specifications*. No direct pay will be made for the staking of the safety fence. All stakeouts for safety fence shall be considered incidental to the work being paid for as "Construction Surveying", except that where there is no pay item for construction surveying, all safety fence stakeout will be performed by state forces.

The Contractor shall be required to maintain the safety fence in a satisfactory condition for the duration of the project as determined by the Engineer.

(B) Boundary Flagging

Boundary flagging delineation of interior boundaries shall consist of wooden stakes on 25 feet maximum intervals with highly visible orange flagging attached. Stakes shall be installed a minimum of 6" into the ground. Interior boundaries may be staked on a tangent that runs parallel to buffer but must not encroach on the buffer at any location. Interior boundaries of hand clearing shall be identified with a different colored flagging to distinguish it from mechanized clearing.

Boundary flagging delineation of interior boundaries will be placed in accordance with Article 105-9 or Article 801-1 of the *Standard Specifications*. No direct pay will be made for delineation of the interior boundaries. This delineation will be considered incidental to the work being paid for as *Construction Surveying*, except that where there is no pay item or construction surveying the cost of boundary flagging delineation shall be included in the unit prices bid for the various items in the contract. Installation for delineation of all jurisdictional boundaries at staging areas, waste sites, or borrow pits shall consist of wooden stakes on 25 feet maximum intervals with highly visible orange flagging attached. Stakes shall be installed a minimum of 6" into the ground. Additional flagging may be placed on overhanging vegetation to enhance visibility but does not substitute for installation of stakes.

Installation of boundary flagging for delineation of all jurisdictional boundaries at staging areas, waste sites, or borrow pits shall be performed in accordance with Subarticle 230-4(B)(5) or Subarticle 802-2(F) of the *Standard Specifications*. No direct pay will be made for this delineation, as the cost of same shall be included in the unit prices bid for the various items in the contract.

The Contractor shall be required to maintain alternative stakes and highly visible flagging in a satisfactory condition for the duration of the project as determined by the Engineer.

Measurement and Payment

Safety Fence will be measured and paid as the actual number of linear feet of polyethylene or polypropylene fence installed in place and accepted. Such payment will be full compensation

including but not limited to furnishing and installing fence geotextile with necessary posts and post bracing, staples, tie wires, tools, equipment and incidentals necessary to complete this work.

Payment will be made under:

Pay Item

Safety Fence

Pay Unit

Linear Foot

COIR FIBER WATTLES WITH POLYACRYLAMIDE (PAM):

Description

Coir Fiber Wattles are tubular products consisting of coir fibers (coconut fibers) encased in coir fiber netting. Coir Fiber Wattles are used on slopes or channels to intercept runoff and act as a velocity break. Coir Fiber Wattles are to be placed at locations shown on the plans or as directed. Installation shall follow the detail provided in the plans and as directed. Work includes furnishing materials, installation of coir fiber wattles, matting installation, PAM application, and removing wattles.

Materials

Coir Fiber Wattle shall meet the following specifications:

100% Coir (Coconut) Fibers	
Minimum Diameter	12 in.
Minimum Density	3.5 lb/ft ³ +/- 10%
Net Material	Coir Fiber
Net Openings	2 in. x 2 in.
Net Strength	90 lbs.
Minimum Weight	2.6 lbs./ft. +/- 10%

Anchors: Stakes shall be used as anchors.

Wooden Stakes:

Provide hardwood stakes a minimum of 2-ft. long with a 2 in. x 2 in. nominal square cross section. One end of the stake must be sharpened or beveled to facilitate driving down into the underlying soil.

Matting shall meet the requirements of Article 1060-8 of the *Standard Specifications*, or shall meet specifications provided elsewhere in this contract.

Provide staples made of 0.125" diameter new steel wire formed into a *u* shape not less than 12" in length with a throat of 1" in width.

Polyacrylamide (PAM) shall be applied in powder form and shall be anionic or neutrally charged. Soil samples shall be obtained in areas where the wattles will be placed, and from offsite material used to construct the roadway, and analyzed for the appropriate PAM flocculant to be utilized with each wattle. The PAM product used shall be listed on the North Carolina Department of Environmental Quality Division of Water Resources web site as an approved PAM product for use in North Carolina.

Construction Methods

Coir Fiber Wattles shall be secured to the soil by wire staples approximately every 1 linear foot and at the end of each section of wattle. A minimum of 4 stakes shall be installed on the downstream side of the wattle with a maximum spacing of 2 linear feet along the wattle, and according to the detail. Install a minimum of 2 stakes on the upstream side of the wattle according to the detail provided in the plans. Stakes shall be driven into the ground a minimum of 10 in. with no more than 2 in. projecting from the top of the wattle. Drive stakes at an angle according to the detail provided in the plans.

Only install coir fiber wattle(s) to a height in ditch so flow will not wash around wattle and scour ditch slopes and according to the detail provided in the plans and as directed. Overlap adjoining sections of wattles a minimum of 6 in.

Installation of matting shall be in accordance with the detail provided in the plans, and in accordance with Article 1631-3 of the *Standard Specifications*, or in accordance with specifications provided elsewhere in this contract.

Apply PAM over the lower center portion of the coir fiber wattle where the water is going to flow over at a rate of 2 ounces per wattle, and 1 ounce of PAM on matting on each side of the wattle. PAM applications shall be done during construction activities after every rainfall event that is equal to or exceeds 0.50 in.

The Contractor shall maintain the coir fiber wattles until the project is accepted or until the wattles are removed, and shall remove and dispose of silt accumulations at the wattles when so directed in accordance with the requirements of Section 1630 of the *Standard Specifications*.

Measurement and Payment

Coir Fiber Wattles will be measured and paid for by the actual number of linear feet of wattles which are installed and accepted. Such price and payment will be full compensation for all work covered by this section, including, but not limited to, furnishing all materials, labor, equipment and incidentals necessary to install the *Coir Fiber Wattles*.

Matting will be measured and paid for in accordance with Article 1631-4 of the *Standard Specifications*, or in accordance with specifications provided elsewhere in this contract.

Polyacrylamide(PAM) will be measured and paid for by the actual weight in pounds of PAM applied to the coir fiber wattles. Such price and payment will be full compensation for all work

covered by this section, including, but not limited to, furnishing all materials, labor, equipment and incidentals necessary to apply the *Polyacrylamide(PAM)*.

Payment will be made under:

Pay Item	Pay Unit
Polyacrylamide(PAM)	Pound
Coir Fiber Wattle	Linear Foot

SILT FENCE COIR FIBER WATTLE BREAK:

(8-21-12) 1605,1630

Description

Silt fence coir fiber wattle breaks are tubular products consisting of coir fibers (coconut fibers) encased in coir fiber netting and used in conjunction with temporary silt fence at the toe of fills to intercept runoff. Silt fence coir fiber wattle breaks are to be placed at locations shown on the plans or as directed. Installation shall follow the detail provided in the plans and as directed. Work includes furnishing materials, installation, maintenance and removing Silt fence coir fiber wattle breaks.

Materials

Coir fiber wattle shall meet the following specifications:

100% Coir (Coconut) Fibers	
Minimum Diameter	12"
Minimum Length	10 ft
Minimum Density	3.5 lb/cf ± 10%
Net Material	Coir Fiber
Net Openings	2" x 2"
Net Strength	90 lb.
Minimum Weight	2.6 lb/ft ± 10%

Stakes shall be used as anchors. Provide hardwood stakes a minimum of 2-ft long with a 2" x 2" nominal square cross section. One end of the stake shall be sharpened or beveled to facilitate driving down into the underlying soil.

Provide staples made of 0.125" diameter new steel wire formed into a U-shape not less than 12" in length with a throat of 1" in width.

Construction Methods

Excavate a trench the entire length of each wattle with a depth of 1" to 2" for the wattle to be placed. Secure silt fence coir fiber wattle breaks to the soil by wire staples approximately every linear foot and at the end of each wattle. Install at least 4 stakes on the downslope side of the

wattle with a maximum spacing of 2 linear feet and according to the detail. Install at least 2 stakes on the upslope side of the silt fence coir fiber wattle break according to the detail provided in the plans. Drive stakes into the ground at least 10" with no more than 2" projecting from the top of the wattle. Drive stakes at an angle according to the detail provided in the plans.

Install temporary silt fence in accordance with Section 1605 of the *Standard Specifications* and overlap each downslope side of silt fence wattle break by 6".

Maintain the silt fence coir fiber wattle breaks until the project is accepted or until the silt fence coir fiber wattle breaks are removed, and remove and dispose of silt accumulations at the silt fence coir fiber wattle breaks when so directed in accordance with Section 1630 of the *Standard Specifications*.

Measurement and Payment

Coir Fiber Wattle will be measured and paid as the actual number of linear feet of wattles installed and accepted. Such price and payment will be full compensation for all work covered by this provision, including, but not limited to, furnishing all materials, labor, equipment and incidentals necessary to install the silt fence coir fiber wattle break.

Payment will be made under:

Pay Item	Pay Unit
Coir Fiber Wattle	Linear Foot

TEMPORARY ROCK SILT CHECK TYPE A WITH EXCELSIOR MATTING AND POLYACRYLAMIDE (PAM):

Description

Temporary Rock Silt Checks Type A with Excelsior Matting and Polyacrylamide (PAM) are devices utilized in temporary and permanent ditches to reduce runoff velocity and incorporate PAM into the construction runoff to increase settling of sediment particles and reduce turbidity of runoff. Temporary Rock Silt Checks Type A with Excelsior Matting and PAM are to be placed at locations shown on the plans or as directed. Installation shall follow the detail provided in the plans and as directed. Work includes furnishing materials, installation of Temporary Rock Silt Checks Type A, matting installation, PAM application, and removing Temporary Rock Silt Checks Type A with Excelsior Matting and PAM.

Materials

Structural stone shall be class B stone that meets the requirements of Section 1042 of the *Standard Specifications* for Stone for Erosion Control, Class B.

Sediment control stone shall be #5 or #57 stone, which meets the requirements of Section 1005 of the *Standard Specifications* for these stone sizes.

Matting shall meet the requirements of Excelsior Matting in Subarticle 1060-8(B) of the *Standard Specifications*, or shall meet specifications provided elsewhere in this contract.

Polyacrylamide (PAM) shall be applied in powder form and shall be anionic or neutrally charged. Soil samples shall be obtained in areas where the Temporary Rock Silt Checks Type A with Excelsior Matting and PAM will be placed, and from offsite material used to construct the roadway, and analyzed for the appropriate PAM flocculant to be utilized with each Temporary Rock Silt Check Type A. The PAM product used shall be listed on the North Carolina Department of Environmental Quality Division of Water Resources web site as an approved PAM product for use in North Carolina.

Construction Methods

Temporary Rock Silt Checks Type A shall be installed in accordance with Subarticle 1633-3(A) of the *Standard Specifications*, Roadway Standard Drawing No. 1633.01 and the detail provided in the plans.

Installation of matting shall be in accordance with the detail provided in the plans, and anchored by placing Class B stone on top of the matting at the upper and lower ends.

Apply PAM at a rate of 4 ounces over the center portion of the Temporary Rock Silt Checks Type A and matting where the water is going to flow over. PAM applications shall be done during construction activities and after every rainfall event that is equal to or exceeds 0.50 in.

The Contractor shall maintain the Temporary Rock Silt Checks Type A with Excelsior Matting and PAM until the project is accepted or until the Temporary Rock Silt Checks Type A with Excelsior Matting and PAM are removed, and shall remove and dispose of silt accumulations at the Temporary Rock Silt Checks Type A with Excelsior Matting and PAM when so directed in accordance with the requirements of Section 1630 of the *Standard Specifications*.

Measurement and Payment

Temporary Rock Silt Checks Type A will be measured and paid for in accordance with Article 1633-5 of the *Standard Specifications*, or in accordance with specifications provided elsewhere in this contract.

Matting will be measured and paid for in accordance with Article 1631-4 of the *Standard Specifications*, or in accordance with specifications provided elsewhere in this contract.

Polyacrylamide(PAM) will be measured and paid for by the actual weight in pounds of PAM applied to the Temporary Rock Silt Checks Type A. Such price and payment will be full compensation for all work covered by this section, including, but not limited to, furnishing all materials, labor, equipment and incidentals necessary to apply the *Polyacrylamide(PAM)*.

Payment will be made under:

Pay Item	Pay Unit
Polyacrylamide(PAM)	Pound

IMPERVIOUS DIKE:

Description

This work consists of furnishing, installing, maintaining, and removing an *Impervious Dike* for the purpose of diverting normal stream flow around the construction site. The Contractor shall construct an impervious dike in such a manner approved by the Engineer. The impervious dike shall not permit seepage of water into the construction site or contribute to siltation of the stream. The impervious dike shall be constructed of an acceptable material in the locations noted on the plans or as directed.

Materials

Acceptable materials shall include but not be limited to sheet piles, sandbags, and/or the placement of an acceptable size stone lined with polypropylene or other impervious geotextile.

Earth material shall not be used to construct an impervious dike when it is in direct contact with the stream unless vegetation can be established before contact with the stream takes place.

Measurement and Payment

Impervious Dike will be measured and paid as the actual number of linear feet of impervious dike(s) constructed, measured in place from end to end of each separate installation that has been completed and accepted. Such price and payment will be full compensation for all work including but not limited to furnishing materials, construction, maintenance, and removal of the impervious dike.

Payment will be made under:

Pay Item	Pay Unit
Impervious Dike	Linear Foot

TEMPORARY PIPE FOR CULVERT CONSTRUCTION:

Description

This work consists of furnishing, installing, maintaining and removing any and all temporary pipe used on this project in conjunction with the culvert construction.

Construction Methods

The Contractor shall install temporary pipe in locations shown on the plans in such a manner approved by the Engineer. The temporary pipe shall provide a passageway for the stream through the work-site. The minimum size requirements will be as stated on the erosion control plans.

Measurement and Payment

___" *Temporary Pipe* will be measured and paid for at the contract unit price per linear foot of temporary pipe approved by the Engineer and measured in place from end to end. Such price and payment will be full compensation for all work covered by this section including but not limited to furnishing all materials required for installation, construction, maintenance, and removal of temporary pipe.

Payment will be made under:

Pay Item	Pay Unit
___" Temporary Pipe	Linear Foot

COIR FIBER MAT:

Description

Furnish material, install and maintain coir fiber mat in locations shown on the plans or in locations as directed. Work includes providing all materials, excavating and backfilling, and placing and securing coir fiber mat with stakes, steel reinforcement bars or staples as directed.

Materials

Item	Section
Coir Fiber Mat	1060-14

anchors: Stakes, reinforcement bars, or staples shall be used as anchors.

Wooden Stakes:

Provide hardwood stakes 12"- 24" long with a 2" x 2" nominal square cross section. One end of the stake must be sharpened or beveled to facilitate driving through the coir fiber mat and down into the underlying soil. The other end of the stake needs to have a 1"- 2" long head at the top with a 1"- 2" notch following to catch and secure the coir fiber mat.

Steel Reinforcement Bars:

Provide uncoated #10 steel reinforcement bars 24" nominal length. The bars shall have a 4" diameter bend at one end with a 4" straight section at the tip to catch and secure the coir fiber mat.

Staples:

Provide staples made of 0.125" diameter new steel wire formed into a *u* shape not less than 12" in length with a throat of 1" in width.

Construction Methods

Place the coir fiber mat immediately upon final grading. Provide a smooth soil surface free from stones, clods, or debris that will prevent the contact of the mat with the soil. Unroll the mat and apply without stretching such that it will lie smoothly but loosely on the soil surface.

For stream relocation applications, take care to preserve the required line, grade, and cross section of the area covered. Bury the top slope end of each piece of mat in a narrow trench at least 6 in. deep and tamp firmly. Where one roll of matting ends and a second roll begins, overlap the end of the upper roll over the buried end of the second roll so there is a 6 in. overlap. Construct check trenches at least 12 in. deep every 50 ft. longitudinally along the edges of the mat or as directed. Fold over and bury mat to the full depth of the trench, close and tamp firmly. Overlap mat at least 6 in. where 2 or more widths of mat are installed side by side.

Place anchors across the mat at the ends approximately 1 ft. apart. Place anchors along the outer edges and down the center of the mat 3 ft. apart.

Adjustments in the trenching or anchoring requirements to fit individual site conditions may be required.

Measurement and Payment

Coir Fiber Mat will be measured and paid for as the actual number of square yards measured along the surface of the ground over which coir fiber mat is installed and accepted.

No measurement will be made for anchor items.

Payment will be made under:

Pay Item	Pay Unit
Coir Fiber Mat	Square Yard

STREAM CHANNEL RELOCATION LIMITATIONS:

The following sequence of construction shall be followed in the areas designated on the plans as stream relocations. Failure on the part of the Contractor to follow this sequence, and complete each step prior to proceeding in this area as specified, will be just cause for the Engineer to direct the suspension of work in accordance with Article 108-7 of the *Standard Specifications*.

- (A) Clear, but do not grub area within the Environmentally Sensitive Area on the existing stream to be relocated.

- (B) Construct and stabilize, with vegetation or erosion control materials sufficient to restrain erosion, the proposed stream channel relocation as shown on the plans.
- (C) Divert water into newly constructed channel only after it has been stabilized and approved.
- (D) Begin grubbing and/or grading within the Environmentally Sensitive Area of the existing stream.

The Contractor shall perform seeding and mulching and install erosion control matting to all cut/fill slopes adjacent to stream relocations in accordance with the contract.

The above requirements apply to the stream channels being constructed at the following stations:

Approx. Sta. 20+10 to 24+00 -L- RT

STREAMBANK REFORESTATION:

Description

Streambank Reforestation will be planted in areas designated on the plans and as directed. See the Streambank Reforestation Detail Sheets.

The entire *Streambank Reforestation* operation shall comply with the requirements of Section 1670 of the *Standard Specifications*.

Materials

Item	Section
Coir Fiber Mat	1060-14

Live Stakes:

Type I Streambank Reforestation shall be live stakes, planted along both streambanks. Live stakes shall be ½" - 2" in diameter. Stakes shall also be 2 ft. - 3 ft. in length.

Live staking plant material shall consist of a random mix made up of 50% Black Willow (*Salix nigra*) and 50% Silky Dogwood (*Cornus amomum*). Other species may be substituted upon approval of the Engineer. All plant material shall be harvested locally (within the same physiographic ecoregion and plant hardiness zone) or purchased from a local nursery, with the approval of the Engineer. All live stakes shall be dormant at time of acquisition and planting.

Staples, stakes, or reinforcement bars shall be used as anchors and shall meet the following requirements:

Wooden Stakes:

Provide hardwood stakes 12" - 24" long with a 2" x 2" nominal square cross section. One end of the stake must be sharpened or beveled to facilitate driving through the coir fiber

mat and down into the underlying soil. The other end of the stake needs to have a 1"- 2" long head at the top with a 1"- 2" notch following to catch and secure the coir fiber mat.

Steel Reinforcement Bars:

Provide uncoated #10 steel reinforcement bars 24" nominal length. The bars shall have a 4" diameter bend at one end with a 4" straight section at the tip to catch and secure the coir fiber mat.

Staples:

Provide staples made of 0.125" diameter new steel wire formed into a *u* shape not less than 12" in length with a throat of 1" in width.

Bare Root Seedlings:

Type II Streambank Reforestation shall be bare root seedlings 12"-18" tall.

Construction Methods

Coir fiber matting shall be installed on the streambanks where live staking is to be planted as shown on the Streambank Reforestation Detail Sheets and in locations as directed. Work includes providing all materials, excavating and backfilling, and placing and securing coir fiber mat.

Provide a smooth soil surface free from stones, clods, or debris that will prevent the contact of the matting with the soil. Place the matting immediately upon final grading and permanent seeding. Take care to preserve the required line, grade, and cross section of the area covered.

Unroll the matting and apply without stretching such that it will lie smoothly but loosely on the soil surface. Bury the top slope end of each piece of matting in a narrow trench at least 6" deep and tamp firmly. Where one roll of matting ends and a second roll begins, overlap the end of the upper roll over the buried end of the second roll so there is a 6" overlap. Construct check trenches at least 12" deep every 50 ft. longitudinally along the edges of the matting, or as directed. Fold over and bury matting to the full depth of the trench, close and tamp firmly. Overlap matting at least 6" where 2 or more widths of matting are installed side by side.

Wooden stakes, reinforcement bars, or staples may be used as anchors in accordance with the Streambank Reforestation Detail Sheets and as directed. Place anchors across the matting at ends, junctions, and check trenches approximately 1 ft. apart. Place anchors down the center of each strip of matting 3 ft. apart. Place anchors along all lapped edges 1 ft. apart. Refer to the Streambank Reforestation Detail Sheets for anchoring pattern. The Engineer may require adjustments in the trenching or anchoring requirements to fit individual site conditions.

During preparation of the live stakes, the basal ends shall be cleanly cut at an angle to facilitate easy insertion into the soil, while the tops shall be cut square or blunt for tamping. All limbs shall be removed from the sides of the live cutting prior to installation.

Live stakes shall be installed within 48 hours of cutting. Outside storage locations should be continually shaded and protected from wind and direct sunlight. Live cut plant material shall remain moist at all times before planting.

Stakes shall be spaced approximately 4 ft. on center. Live stakes shall be installed according to the configuration presented on the Streambank Reforestation Detail Sheets.

Tamp live stakes perpendicularly into the finished bank slope with a dead blow hammer, with buds oriented in an upward direction. Stakes should be tamped until approximately $\frac{3}{4}$ of the stake length is within the ground. The area around each live stake shall be compacted by foot after the live stake has been installed.

1" - 2" shall be cut cleanly off of the top of each live stake with loppers at an angle of approximately 15 degrees following installation. Any stakes that are split or damaged during installation shall be removed and replaced.

The bare root seedlings shall be planted as soon as practical following permanent *Seeding and Mulching*. The seedlings shall be planted from top of bank out, along both sides of the stream, as designated on the plans.

Root dip: The roots of reforestation seedlings shall be coated with a slurry of water, and either a fine clay (kaolin) or a superabsorbent that is designated as a bare root dip. The type, mixture ratio, method of application, and the time of application shall be submitted to the Engineer for approval.

With the approval of the Engineer, seedlings may be coated before delivery to the job or at the time of planting, but at no time shall the roots of the seedlings be allowed to dry out. The roots shall be moistened immediately prior to planting.

Seasonal Limitations: Streambank reforestation shall be planted from November 15 through March 15.

Measurement and Payment

Streambank Reforestation will be measured and paid for as the actual number of acres of land measured along the surface of the ground, which has been acceptably planted in accordance with this section.

Payment will be made under:

Pay Item	Pay Unit
Streambank Reforestation	Acre

FABRIC INSERT INLET PROTECTION DEVICE (HIGH FLOW)

(6-29-17)

Description

This work shall consist of installing, maintaining, and removing *Fabric Insert Inlet Protection Device*, of the type specified, in inlet structures (catch basins, drop inlets, etc) in areas where asphalt or concrete may prevent the proper installation of a Rock Inlet Sediment Traps Type C, or as directed.

Materials

The product shall be a fabric inlet protection device composed of a fitted woven polypropylene geotextile double sewn with nylon thread suspended sack. The *Fabric Insert Inlet Protection Device* shall be manufactured to fit the opening of the catch basin or drop inlet or shall have a deflector to direct runoff from the curb opening into the fabric sack. The *Fabric Insert Inlet Protection Device* shall have a rigid frame or support system to support the loaded weight of the product. The product shall have lifting loops for removing the device from the basin and will have dump straps attached at the bottom to facilitate the emptying of the device. The *Fabric Insert Inlet Protection Device* shall have an overflow system to allow stormwater to enter the inlet structure and avoid ponding on the roadway when the device reaches capacity

The stitching shall meet the following physical properties:

Physical	Test Method	English
Average Wide Width Strength	ASTM D-4884	165 lb/in

The fitted filter assembly shall have the following physical properties:

Physical	Test Method	English
Grab Tensile	ASTM D-4632	255 x 275 lbs
Minimum Puncture Strength	ASTM D-4833	125 lbs
Mullen Burst	ASTM D-3786	420 PSI
Minimum UV Resistance	ASTM D-4355	70 %.
Flow Rate	ASTM D-4491	200 gal/min/ft ²
Apparent Opening	ASTM D-4751	20 US Sieve
Permittivity	ASTM D-4491	1.5 sec ⁻¹

Construction Methods

Strictly comply with manufacturer's installation instructions and recommendations. Maintenance shall include regular daily inspections and after each qualifying rain event. The *Fabric Insert Inlet Protection Device* shall be emptied, cleaned and placed back into the basin when it reaches 50% capacity or as directed.

Measurement and Payment

This work will be paid for at the contract unit price per *Fabric Insert Inlet Protection Device* of the type specified, complete in place and accepted. Such payment shall be full compensation for furnishing and installing the *Fabric Insert Inlet Protection Device* in accordance with this specification and for all required maintenance.

Maintenance of the device, cleanout and disposal of accumulated sediments shall be paid for by *Fabric Insert Inlet Protection Device Cleanout*.

Payment will be made under:

Pay Item	Pay Unit
Fabric Insert Inlet Protection Device	Each
Fabric Insert Inlet Protection Device Cleanout	Each

CONCRETE WASHOUT STRUCTURE:

(12-05-16)

Description

Concrete washout structures are enclosures above or below grade to contain concrete waste water and associated concrete mix from washing out ready-mix trucks, drums, pumps, or other equipment. Concrete washouts must collect and retain all the concrete washout water and solids, so that this material does not migrate to surface waters or into the ground water. These enclosures are not intended for concrete waste not associated with wash out operations.

The concrete washout structure may include constructed devices above or below ground and or commercially available devices designed specifically to capture concrete waste water.

Materials

Item	Section
Temporary Silt Fence	1605

Safety Fence shall meet the specifications as provided elsewhere in this contract.

Geomembrane basin liner shall meet the following minimum physical properties for low permeability; it shall consist of a polypropylene or polyethylene 10 mil think geomembrane. If the minimum setback dimensions can be achieved the liner is not required. (5 feet above groundwater, 50 feet from top of bank of perennial stream, other surface water body, or wetland.)

Construction Methods

Build an enclosed earthen berm or excavate to form an enclosure in accordance with the details and as directed.

Install temporary silt fence around the perimeter of the enclosure in accordance with the details and as directed if structure is not located in an area where existing erosion and sedimentation control devices are capable to containing any loss of sediment.

Post a sign with the words “Concrete Washout” in close proximity of the concrete washout area, so it is clearly visible to site personnel. Install safety fence as directed for visibility to construction traffic.

The construction details for the above grade and below grade concrete washout structures can be found on the following web page link:

http://www.ncdot.gov/doh/operations/dp_chief_eng/roadside/soil_water/details/

[Alternate details for accommodating concrete washout may be submitted for review and approval.](#)

[The alternate details shall include the method used to retain and dispose of the concrete waste water within the project limits and in accordance with the minimum setback requirements.](#) (5 feet above groundwater, 50 feet from top of bank of perennial stream, other surface water body, or wetland.)

Maintenance and Removal

Maintain the concrete washout structure(s) to provide adequate holding capacity plus a minimum freeboard of 12 inches. Remove and dispose of hardened concrete and return the structure to a functional condition after reaching 75% capacity.

Inspect concrete washout structures for damage and maintain for effectiveness.

Remove the concrete washout structures and sign upon project completion. Grade the earth material to match the existing contours and permanently seed and mulch area.

Measurement and Payment

Concrete Washout Structure will be paid for per each enclosure installed in accordance with the details. If alternate details are approved then those details will also be paid for per each approved and installed device.

Temporary Silt Fence will be measured and paid for in accordance with Article 1605-5 of the *Standard Specifications*.

No measurement will be made for other items or for over excavation or stockpiling.

Payment will be made under:

Pay Item	Pay Unit
Concrete Washout Structure	Each

DocuSigned by:
Regina M. Muncey
 C7FE51B3-2E44FA

10/4/2018

Document not considered final unless all signatures completed.

**Signals and Intelligent Transportation Systems
 Project Special Provisions
 (Version 18.1)**

Prepared By: *edh*
 4-Oct-18

Contents

1. 2018 STANDARD SPECIFICATIONS FOR ROADS & STRUCTURES.....3

1.1. GENERAL REQUIREMENTS – CONSTRUCTION METHODS (1700-3(K)) 3

1.2. WOOD POLES – CONSTRUCTION METHODS (1720-3) 3

2. SIGNAL HEADS.....3

2.1. MATERIALS 3

A. General: 3

B. Vehicle Signal Heads: 4

C. Pedestrian Signal Heads: 7

D. Signal Cable: 8

3. CONTROLLERS WITH CABINETS9

3.1. MATERIALS – GENERAL CABINETS 9

3.2. MATERIALS – TYPE 170E CABINETS 10

A. Type 170 E Cabinets General: 10

B. Type 170 E Cabinet Electrical Requirements: 10

C. Type 170 E Cabinet Physical Requirements: 18

D. Model 2018 Enhanced Conflict Monitor: 20

3.3. MATERIALS – TYPE 170 DETECTOR SENSOR UNITS 30

3.4. MATERIALS – TYPE 2070E CONTROLLERS 30

4. VIDEO IMAGING LOOP EMULATOR DETECTOR SYSTEMS31

4.1. DESCRIPTION 31

4.2. MATERIALS 31

A. General: 31

B. Loop Emulator System: 33

C. Video Imaging Loop Emulator System Support: 34

4.3. CONSTRUCTION METHODS 34

4.4. MEASUREMENT AND PAYMENT 35

5. TRAFFIC SIGNAL SUPPORTS.....35

5.1. METAL TRAFFIC SIGNAL SUPPORTS – ALL POLES 35

A. General: 35

B. Materials: 38

C. Construction Methods: 39

5.2. METAL POLE UPRIGHTS (VERTICAL MEMBERS) 39

A. Materials: 39

B. Construction Methods: 41

5.3. MAST ARMS 41

A. Materials: 41

B. Construction Methods: 41

5.4. DRILLED PIER FOUNDATIONS FOR METAL TRAFFIC SIGNAL POLES 42

- A. *Description:*..... 42
- B. *Soil Test and Foundation Determination:* 43
- C. *Drilled Pier Construction:*..... 45
- 5.5. CUSTOM DESIGN OF TRAFFIC SIGNAL SUPPORTS 45
 - A. *General:*..... 45
 - B. *Metal Poles:*..... 46
 - C. *Mast Arms:* 48
- 5.6. METAL SIGNAL POLE REMOVALS 48
 - A. *Description:* 48
 - B. *Construction Methods:* 48
- 5.7. POLE NUMBERING SYSTEM 49
 - A. *New Poles* 49
- 5.8. MEASUREMENT AND PAYMENT 49
- 6. PROTECTIVE COATING FOR METAL POLES 50**
 - 6.1. DESCRIPTION..... 50
 - 6.2. MATERIALS 50
 - 6.3. COATING SHOP APPROVAL..... 50
 - 6.4. POWDER COATING 51
 - A. *Galvanizing:* 51
 - B. *Surface Preparation:* 51
 - C. *Powder Coating Application and Curing:* 52
 - D. *Quality Control:*..... 52
 - E. *Storage, Shipping, and Handling:* 52
 - F. *Repair of Powder Coated Material:* 52
 - 6.5. ACRYLIC PRIMER AND TOP COAT PAINT SYSTEM 4 (MODIFIED) 52
 - A. *Description:* 52
 - B. *Surface Preparation:* 53
 - C. *Materials:* 53
 - D. *Painting:* 53
 - E. *Curing:*..... 54
 - F. *Inspection:* 54
 - G. *Handling:*..... 54
 - H. *Repair of Damaged Coating:*..... 54
 - 6.6. MEASUREMENT AND PAYMENT 54

1. 2018 STANDARD SPECIFICATIONS FOR ROADS & STRUCTURES

The 2018 Standard Specifications are revised as follows:

1.1. GENERAL REQUIREMENTS – Construction Methods (1700-3(K))

Page 17-4, revise sentence starting on line 14 to read “Modify existing electrical services, as necessary, to meet the grounding requirements of the NEC, these *Standard Specifications*, *Standard Drawings*, and the project plans.”

Page 17-4, revise sentence beginning on line 21 to read “Furnish and install additional ground rods to grounding electrode system as necessary to meet the *Standard Specifications*, *Standard Drawings*, and test requirements.”

1.2. WOOD POLES – Construction Methods (1720-3)

Page 17-18, revise sentence starting on line 13 to read “On new Department-owned poles, install a grounding system consisting of #6 AWG solid bare copper wire that is mechanically crimped using an irreversible compression tool with die to a single ground rod installed at base of pole or to the electrical service grounding electrode system located within 10 feet of the pole.”

2. SIGNAL HEADS

2.1. MATERIALS

A. General:

Fabricate vehicle signal head housings and end caps from die-cast aluminum. Fabricate 12-inch and 16-inch pedestrian signal head housings and end caps from die-cast aluminum. Fabricate 9-inch pedestrian signal head housings, end caps, and visors from virgin polycarbonate material. Provide visor mounting screws, door latches, and hinge pins fabricated from stainless steel. Provide interior screws, fasteners, and metal parts fabricated from stainless steel.

Fabricate tunnel and traditional visors from sheet aluminum.

Paint all surfaces inside and outside of signal housings and doors. Paint outside surfaces of tunnel and traditional visors, wire outlet bodies, wire entrance fitting brackets and end caps when supplied as components of messenger cable mounting assemblies, pole and pedestal mounting assemblies, and pedestrian pushbutton housings. Have electrostatically-applied, fused-polyester paint in BLACK (Federal Standard 595C, Color Chip Number 37038) a minimum of 2.5 to 3.5 mils thick. Do not apply paint to the latching hardware, rigid vehicle signal head mounting brackets for mast-arm attachments, messenger cable hanger components or balance adjuster components.

Have the interior surfaces of tunnel and traditional visors painted an alkyd urea black synthetic baking enamel with a minimum gloss reflectance and meeting the requirements of MIL-E-10169, “Enamel Heat Resisting, Instrument Black.”

Where required, provide polycarbonate signal heads and visors that comply with the provisions pertaining to the aluminum signal heads listed on the QPL with the following exceptions:

Fabricate signal head housings, end caps, and visors from virgin polycarbonate material. Provide UV stabilized polycarbonate plastic with a minimum thickness of 0.1 ± 0.01 inches that is highway BLACK (Federal Standard 595C, Color Chip Number 37038). Ensure the color is incorporated into the plastic material before molding the signal head housings and end caps. Ensure the plastic formulation provides the following physical properties in the assembly (tests may be performed on separately molded specimens):

Test	Required	Method
Specific Gravity	1.17 minimum	ASTM D 792
Flammability	Self-extinguishing	ASTM D 635
Tensile Strength, yield, PSI	8500 minimum	ASTM D 638
Izod impact strength, ft-lb/in [notched, 1/8 inch]	12 minimum	ASTM D 256

For light emitting diode (LED) traffic signal modules, provide the following requirements for inclusion on the Department's Qualified Products List for traffic signal equipment.

1. Sample submittal,
2. Third-party independent laboratory testing results for each submitted module with evidence of testing and conformance with all of the Design Qualification Testing specified in section 6.4 of each of the following Institute of Transportation Engineers (ITE) specifications:
 - Vehicle Traffic Control Signal Heads – Light Emitting Diode (LED) Circular Signal Supplement
 - Vehicle Traffic Control Signal Heads – Light Emitting Diode (LED) Vehicle Arrow Traffic Signal Supplement
 - Pedestrian Traffic Control Signal Indications –Light Emitting Diode (LED) Signal Modules.

(Note: The Department currently recognizes two approved independent testing laboratories. They are Intertek ETL Semko and Light Metrics, Incorporated with Garwood Laboratories. Independent laboratory tests from other laboratories may be considered as part of the QPL submittal at the discretion of the Department,

3. Evidence of conformance with the requirements of these specifications,
4. A manufacturer's warranty statement in accordance with the required warranty, and
5. Submittal of manufacturer's design and production documentation for the model, including but not limited to, electrical schematics, electronic component values, proprietary part numbers, bill of materials, and production electrical and photometric test parameters.
6. Evidence of approval of the product to bear the Intertek ETL Verified product label for LED traffic signal modules.

In addition to meeting the performance requirements for the minimum period of 60 months, provide a written warranty against defects in materials and workmanship for the modules for a period of 60 months after installation of the modules. During the warranty period, the manufacturer must provide new replacement modules within 45 days of receipt of modules that have failed at no cost to the State. Repaired or refurbished modules may not be used to fulfill the manufacturer's warranty obligations. Provide manufacturer's warranty documentation to the Department during evaluation of product for inclusion on Qualified Products List (QPL).

B. Vehicle Signal Heads:

Comply with the ITE standard "Vehicle Traffic Control Signal Heads". Provide housings with provisions for attaching backplates.

Provide visors that are 10 inches in length for 12-inch vehicle signal heads.

Provide a termination block with one empty terminal for field wiring for each indication plus one empty terminal for the neutral conductor. Have all signal sections wired to the termination block. Provide barriers between the terminals that have terminal screws with a minimum Number 8 thread size and that will accommodate and secure spade lugs sized for a Number 10 terminal screw.

Mount termination blocks in the yellow signal head sections on all in-line vehicle signal heads. Mount the termination block in the red section on five-section vehicle signal heads.

Furnish vehicle signal head interconnecting brackets. Provide one-piece aluminum brackets less than 4.5 inches in height and with no threaded pipe connections. Provide hand holes on the bottom of the brackets to aid in installing wires to the signal heads. Lower brackets that carry no wires and are used only for connecting the bottom signal sections together may be flat in construction.

For messenger cable mounting, provide messenger cable hangers, wire outlet bodies, balance adjusters, bottom caps, wire entrance fitting brackets, and all other hardware necessary to make complete, watertight connections of the vehicle signal heads to the messenger cable. Fabricate messenger cable hanger components, wire outlet bodies and balance adjuster components from stainless steel or malleable iron galvanized in accordance with ASTM A153 (Class A) or ASTM A123. Provide serrated rings made of aluminum. Provide messenger cable hangers with U-bolt clamps. Fabricate washers, screws, hex-head bolts and associated nuts, clevis pins, cotter pins, U-bolt clamps and nuts from stainless steel.

For mast-arm mounting, provide rigid vehicle signal head mounting brackets and all other hardware necessary to make complete, watertight connections of the vehicle signal heads to the mast arms and to provide a means for vertically adjusting the vehicle signal heads to proper alignment. Fabricate the mounting assemblies from aluminum, and provide serrated rings made of aluminum. Provide stainless steel cable attachment assemblies to secure the brackets to the mast arms. Ensure all fastening hardware and fasteners are fabricated from stainless steel.

Provide LED vehicular traffic signal modules (hereafter referred to as modules) that consist of an assembly that uses LEDs as the light source in lieu of an incandescent lamp for use in traffic signal sections. Use LEDs that are aluminum indium gallium phosphorus (AlInGaP) technology for red and yellow indications and indium gallium nitride (InGaN) for green indications. Install the ultra bright type LEDs that are rated for 100,000 hours of continuous operation from -40°F to +165°F. Design modules to have a minimum useful life of 60 months and to meet all parameters of this specification during this period of useful life.

For the modules, provide spade terminals crimped to the lead wires and sized for a #10 screw connection to the existing terminal block in a standard signal head. Do not provide other types of crimped terminals with a spade adapter.

Ensure the power supply is integral to the module assembly. On the back of the module, permanently mark the date of manufacture (month & year) or some other method of identifying date of manufacture.

Tint the red, yellow and green lenses to correspond with the wavelength (chromaticity) of the LED. Transparent tinting films are unacceptable. Provide a lens that is integral to the unit with a smooth outer surface.

1. LED Circular Signal Modules:

Provide modules in the following configurations: 12-inch circular sections, and 8-inch circular sections. All makes and models of LED modules purchased for use on the State Highway System shall appear on the current NCDOT Traffic Signal Qualified Products List (QPL).

Provide the manufacturer's model number and the product number (assigned by the Department) for each module that appears on the 2018 or most recent Qualified Products List. In addition, provide manufacturer's certification in accordance with Article 106-3 of the *Standard Specifications*, that each module meets or exceeds the ITE "Vehicle Traffic Control Signal Heads – Light Emitting Diode (LED) Circular Signal Supplement" dated June 27, 2005 (hereafter referred to as VTCSH Circular Supplement) and other requirements stated in this specification.

Provide modules that meet the following requirements when tested under the procedures outlined in the VTCSH Circular Supplement:

Module Type	Max. Wattage at 165° F	Nominal Wattage at 77° F
12-inch red circular	17	11
12-inch green circular	15	15

For yellow circular signal modules, provide modules tested under the procedures outlined in the VTCSH Circular Supplement to insure power required at 77° F is 22 Watts or less for the 12-inch circular module and 13 Watts or less for the 8-inch circular module.

Note: Use a wattmeter having an accuracy of $\pm 1\%$ to measure the nominal wattage and maximum wattage of a circular traffic signal module. Power may also be derived from voltage, current and power factor measurements.

2. LED Arrow Signal Modules

Provide 12-inch omnidirectional arrow signal modules. All makes and models of LED modules purchased for use on the State Highway System shall appear on the current NCDOT Traffic Signal Qualified Products List (QPL).

Provide the manufacturer's model number and the product number (assigned by the Department) for each module that appears on the 2018 or most recent Qualified Products List. In addition, provide manufacturer's certification in accordance with Article 106-3 of the *Standard Specifications*, that each module meets or exceeds the requirements for 12-inch omnidirectional modules specified in the ITE "Vehicle Traffic Control Signal Heads – Light Emitting Diode (LED) Vehicle Arrow Traffic Signal Supplement" dated July 1, 2007 (hereafter referred to as VTCSH Arrow Supplement) and other requirements stated in this specification.

Provide modules that meet the following requirements when tested under the procedures outlined in the VTCSH Arrow Supplement:

Module Type	Max. Wattage at 165° F	Nominal Wattage at 77° F
12-inch red arrow	12	9
12-inch green arrow	11	11

For yellow arrow signal modules, provide modules tested under the procedures outlined in the VTCSH Arrow Supplement to insure power required at 77° F is 12 Watts or less.

Note: Use a wattmeter having an accuracy of $\pm 1\%$ to measure the nominal wattage and maximum wattage of an arrow traffic signal module. Power may also be derived from voltage, current and power factor measurements.

C. Pedestrian Signal Heads:

Provide pedestrian signal heads with international symbols that meet the MUTCD. Do not provide letter indications.

Comply with the ITE standard for “Pedestrian Traffic Control Signal Indications” and the following sections of the ITE standard for “Vehicle Traffic Control Signal Heads” in effect on the date of advertisement:

- Section 3.00 - “Physical and Mechanical Requirements”
- Section 4.01 - “Housing, Door, and Visor: General”
- Section 4.04 - “Housing, Door, and Visor: Materials and Fabrication”
- Section 7.00 - “Exterior Finish”

Provide a double-row termination block with three empty terminals and number 10 screws for field wiring. Provide barriers between the terminals that accommodate a spade lug sized for number 10 terminal screws. Mount the termination block in the hand section. Wire all signal sections to the terminal block.

Where required by the plans, provide 16-inch pedestrian signal heads with traditional three-sided, rectangular visors, 6 inches long.

Provide 2-inch diameter pedestrian push-buttons with weather-tight housings fabricated from die-cast aluminum and threading in compliance with the NEC for rigid metal conduit. Provide a weep hole in the housing bottom and ensure that the unit is vandal resistant.

Provide push-button housings that are suitable for mounting on flat or curved surfaces and that will accept 1/2-inch conduit installed in the top. Provide units that have a heavy duty push-button assembly with a sturdy, momentary, normally-open switch. Have contacts that are electrically insulated from the housing and push-button. Ensure that the push-buttons are rated for a minimum of 5 mA at 24 volts DC and 250 mA at 12 volts AC.

Provide standard R10-3 signs with mounting hardware that comply with the MUTCD in effect on the date of advertisement. Provide R10-3E signs for countdown pedestrian heads and R10-3B for non-countdown pedestrian heads.

Design the LED pedestrian traffic signal modules (hereafter referred to as modules) for installation into standard pedestrian traffic signal sections that do not contain the incandescent signal section reflector, lens, eggcrate visor, gasket, or socket. Provide modules that consist of an assembly that uses LEDs as the light source in lieu of an incandescent lamp. Use LEDs that are of the latest aluminum indium gallium phosphorus (AlInGaP) technology for the Portland Orange hand and countdown displays. Use LEDs that are of the latest indium gallium nitride (InGaN) technology for the Lunar White walking man displays. Install the ultra-bright type LEDs that are rated for 100,000 hours of continuous operation from -40°F to $+165^{\circ}\text{F}$. Design modules to have a minimum useful life of 60 months and to meet all parameters of this specification during this period of useful life.

Design all modules to operate using a standard 3 - wire field installation. Provide spade terminals crimped to the lead wires and sized for a #10 screw connection to the existing terminal

block in a standard pedestrian signal housing. Do not provide other types of crimped terminals with a spade adapter.

Ensure the power supply is integral to the module assembly. On the back of the module, permanently mark the date of manufacture (month & year) or some other method of identifying date of manufacture.

Provide modules in the following configuration: 16-inch displays which have the solid hand/walking man overlay on the left and the countdown on the right, and 12-inch displays which have the solid hand/walking man module as an overlay. All makes and models of LED modules purchased for use on the State Highway System shall appear on the current NCDOT Traffic Signal Qualified Products List (QPL).

Provide the manufacturer's model number and the product number (assigned by the Department) for each module that appears on the 2018 or most recent Qualified Products List. In addition, provide manufacturer's certification in accordance with Article 106-3 of the *Standard Specifications*, that each module meets or exceeds the ITE "Pedestrian Traffic Control Signal Indicators - Light Emitting Diode (LED) Signal Modules" dated August 04, 2010 (hereafter referred to as PTCSI Pedestrian Standard) and other requirements stated in this specification.

Provide modules that meet the following requirements when tested under the procedures outlined in the PTCSI Pedestrian Standard:

Module Type	Max. Wattage at 165° F	Nominal Wattage at 77° F
Hand Indication	16	13
Walking Man Indication	12	9
Countdown Indication	16	13

Note: Use a wattmeter having an accuracy of $\pm 1\%$ to measure the nominal wattage and maximum wattage of a circular traffic signal module. Power may also be derived from voltage, current and power factor measurements.

Provide module lens that is hard coated or otherwise made to comply with the material exposure and weathering effects requirements of the Society of Automotive Engineers (SAE) J576. Ensure all exposed components of the module are suitable for prolonged exposure to the environment, without appreciable degradation that would interfere with function or appearance.

Ensure the countdown display continuously monitors the traffic controller to automatically learn the pedestrian phase time and update for subsequent changes to the pedestrian phase time.

Ensure the countdown display begins normal operation upon the completion of the preemption sequence and no more than one pedestrian clearance cycle.

D. Signal Cable:

Furnish 16-4 and 16-7 signal cable that complies with IMSA specification 20-1 except provide the following conductor insulation colors:

- For 16-4 cable: white, yellow, red, and green
- For 16-7 cable: white, yellow, red, green, yellow with black stripe tracer, red with black stripe tracer, and green with black stripe tracer. Apply continuous stripe tracer on conductor insulation with a longitudinal or spiral pattern.

Provide a ripcord to allow the cable jacket to be opened without using a cutter. IMSA specification 19-1 will not be acceptable. Provide a cable jacket labeled with the IMSA specification number and provide conductors constructed of stranded copper.

3. CONTROLLERS WITH CABINETS

3.1.MATERIALS – GENERAL CABINETS

Provide a moisture resistant coating on all circuit boards.

Provide one 20 mm diameter radial lead UL-recognized metal oxide varistor (MOV) between each load switch field terminal and equipment ground. Electrical performance is outlined below.

PROPERTIES OF MOV SURGE PROTECTOR	
Maximum Continuous Applied Voltage at 185° F	150 VAC (RMS) 200 VDC
Maximum Peak 8x20µs Current at 185° F	6500 A
Maximum Energy Rating at 185° F	80 J
Voltage Range 1 mA DC Test at 77° F	212-268 V
Max. Clamping Voltage 8x20µs, 100A at 77° F	395 V
Typical Capacitance (1 MHz) at 77° F	1600 pF

Provide a power line surge protector that is a two-stage device that will allow connection of the radio frequency interference filter between the stages of the device. Ensure that a maximum continuous current is at least 10A at 120V. Ensure that the device can withstand a minimum of 20 peak surge current occurrences at 20,000A for an 8x20 microsecond waveform. Provide a maximum clamp voltage of 395V at 20,000A with a nominal series inductance of 200µh. Ensure that the voltage does not exceed 395V. Provide devices that comply with the following:

Frequency (Hz)	Minimum Insertion Loss (dB)
60	0
10,000	30
50,000	55
100,000	50
500,000	50
2,000,000	60
5,000,000	40
10,000,000	20
20,000,000	25

3.2. MATERIALS – TYPE 170E CABINETS

A. Type 170 E Cabinets General:

Conform to the city of Los Angeles' Specification No. 54-053-08, *Traffic Signal Cabinet Assembly Specification* (dated July 2008), except as required herein.

Furnish model 336S pole mounted cabinets configured for 8 vehicle phases, 4 pedestrian phases, and 6 overlaps. Do not reassign load switches to accommodate overlaps unless shown on electrical details. Provide 336S pole mounted cabinets that are 46" high with 40" high internal rack assemblies.

Furnish model 332 base mounted cabinets configured for 8 vehicle phases, 4 pedestrian phases, and 6 overlaps. When overlaps are required, provide auxiliary output files for the overlaps. Do not reassign load switches to accommodate overlaps unless shown on electrical details.

Provide model 200 load switches, model 222 loop detector sensors, model 252 AC isolators, and model 242 DC isolators according to the electrical details. As a minimum, provide one (1) model 2018 conflict monitor, one (1) model 206L power supply unit, two (2) model 204 flashers, one (1) DC isolator (located in slot I14), and four (4) model 430 flash transfer relays (provide seven (7) model 430 flash transfer relays if auxiliary output file is installed) with each cabinet.

B. Type 170 E Cabinet Electrical Requirements:

Provide a cabinet assembly designed to ensure that upon leaving any cabinet switch or conflict monitor initiated flashing operation, the controller starts up in the programmed start up phases and start up interval.

Furnish two sets of non-fading cabinet wiring diagrams and schematics in a paper envelope or container and placed in the cabinet drawer.

All AC+ power is subject to radio frequency signal suppression.

Provide surge suppression in the cabinet for each type of cabinet device. Provide surge protection for the full capacity of the cabinet input file. Provide surge suppression devices that

operate properly over a temperature range of -40° F to +185° F. Ensure the surge suppression devices provide both common and differential modes of protection.

Provide a pluggable power line surge protector that is installed on the back of the PDA (power distribution assembly) chassis to filter and absorb power line noise and switching transients. Ensure the device incorporates LEDs for failure indication and provides a dry relay contact closure for the purpose of remote sensing. Ensure the device meets the following specifications:

Peak Surge Current (Single pulse, 8x20µs).....	20,000A
Occurrences (8x20µs waveform).....	10 minimum @ 20,000A
Maximum Clamp Voltage.....	395VAC
Operating Current.....	15 amps
Response Time.....	< 5 nanoseconds

Provide a loop surge suppressor for each set of loop terminals in the cabinet. Ensure the device meets the following specifications:

Peak Surge Current (6 times, 8x20µs)	
(Differential Mode).....	400A
(Common Mode).....	1,000A
Occurrences (8x20µs waveform).....	500 min @ 200A
Maximum Clamp Voltage	
(Differential Mode @400A).....	35V
(Common Mode @1,000A).....	35V
Response Time.....	< 5 nanoseconds
Maximum Capacitance.....	35 pF

Provide a data communications surge suppressor for each communications line entering or leaving the cabinet. Ensure the device meets the following specifications:

Peak Surge Current (Single pulse, 8x20µs).....	10,000A
Occurrences (8x20µs waveform).....	100 min @ 2,000A
Maximum Clamp Voltage.....	Rated for equipment protected
Response Time.....	< 1 nanosecond
Maximum Capacitance.....	1,500 pF
Maximum Series Resistance.....	15Ω

Provide a DC signal surge suppressor for each DC input channel in the cabinet. Ensure the device meets the following specifications:

- Peak Surge Current (Single pulse, 8x20µs).....10,000A
- Occurrences (8x20µs waveform).....100 @ 2,000A
- Maximum Clamp Voltage.....30V
- Response Time.....< 1 nanosecond

Provide a 120 VAC signal surge suppressor for each AC+ interconnect signal input. Ensure the device meets the following specifications:

- Peak Surge Current (Single pulse, 8x20µs).....20,000A
- Maximum Clamp Voltage.....350VAC
- Response Time.....< 200 nanoseconds
- Discharge Voltage.....<200 Volts @ 1,000A
- Insulation Resistance.....≥100 MΩ

Provide conductors for surge protection wiring that are of sufficient size (ampacity) to withstand maximum overcurrents which could occur before protective device thresholds are attained and current flow is interrupted.

If additional surge protected power outlets are needed to accommodate fiber transceivers, modems, etc., install a UL listed, industrial, heavy-duty type power outlet strip with a minimum rating of 15 A / 125 VAC, 60 Hz. Provide a strip that has a minimum of 3 grounded outlets. Ensure the power outlet strip plugs into one of the controller unit receptacles located on the rear of the PDA. Ensure power outlet strip is mounted securely; provide strain relief if necessary.

Provide a door switch in the front and a door switch in the rear of the cabinet that will provide the controller unit with a Door Ajar alarm when either the front or the rear door is open. Ensure the door switches apply DC ground to the Input File when either the front door or the rear door is open.

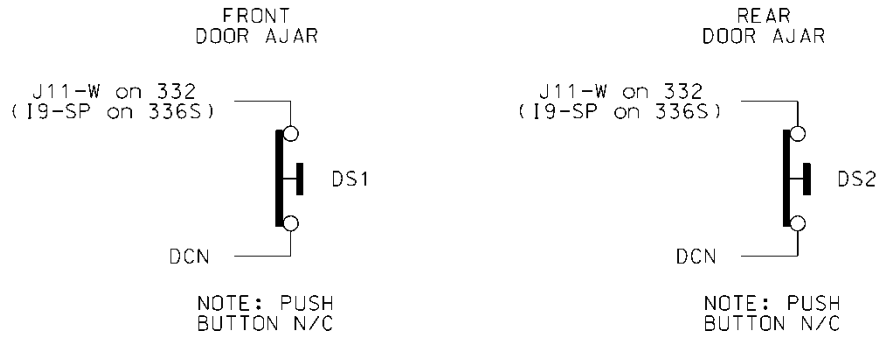

Furnish a fluorescent fixture in the rear across the top of the cabinet and another fluorescent fixture in the front across the top of the cabinet at a minimum. Ensure that the fixtures provide sufficient light to illuminate all terminals, labels, switches, and devices in the cabinet. Conveniently locate the fixtures so as not to interfere with a technician's ability to perform work on any devices or terminals in the cabinet. Provide a protective diffuser to cover exposed bulbs. Install 16 watt T-4 lamps in the fluorescent fixtures. Provide a door switch to provide power to each fixture when the respective door is open. Wire the fluorescent fixtures to the 15 amp ECB (equipment circuit breaker).

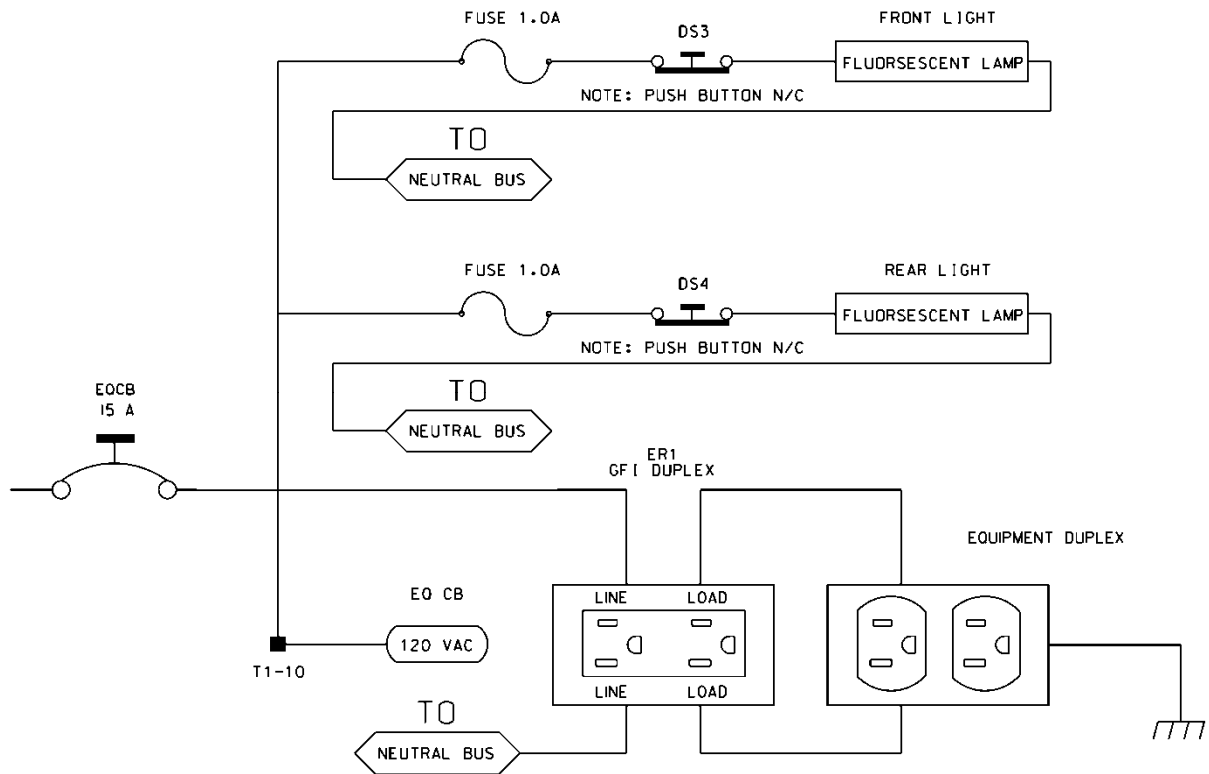

Furnish a police panel with a police panel door. For model 336S cabinets, mount the police panel on the rear door. Ensure that the police panel door permits access to the police panel when the main door is closed. Ensure that no rainwater can enter the cabinet even with the police panel door open. Provide a police panel door hinged on the right side as viewed from the front. Provide a police panel

door lock that is keyed to a standard police/fire call box key. In addition to the requirements of LA Specification No. 54-053-08, provide the police panel with a toggle switch connected to switch the intersection operation between normal stop-and-go operation (AUTO) and manual operation (MANUAL). Ensure that manual control can be implemented using inputs and software such that the controller provides full programmed clearance times for the yellow clearance and red clearance for each phase while under manual control.

Provide a 1/4-inch locking phone jack in the police panel for a hand control to manually control the intersection. Provide sufficient room in the police panel for storage of a hand control and cord.

Ensure the 336S cabinet Input File is wired as follows:

336S Cabinet														
Port-Bit/C-1 Pin Assignment														
Slot #	1	2	3	4	5	6	7	8	9	10	11	12	13	14
C-1 (Spares)	59	60	61	62	63	64	65	66	75	76	77	78	79	80
Port C-1	3-2 56	1-1 39	3-4 58	1-3 41	3-1 55	1-2 40	3-3 57	1-4 42	2-5 51	5-5 71	5-6 72	5-1 67	5-2 68	6-7 81
Port C-1	2-1 47	1-5 43	2-3 49	1-7 45	2-2 48	1-6 44	2-4 50	1-8 46	2-6 52	5-7 73	5-8 74	5-3 69	5-4 70	6-8 82

For model 332 base mounted cabinets, ensure terminals J14-E and J14-K are wired together on the rear of the Input File. Connect TB9-12 (J14 Common) on the Input Panel to T1-2 (AC-) on the rear of the PDA.

Provide detector test switches mounted at the top of the cabinet rack or other convenient location which may be used to place a call on each of eight phases based on the chart below. Provide three positions for each switch: On (place call), Off (normal detector operation), and Momentary On (place momentary call and return to normal detector operation after switch is released). Ensure that the switches are located such that the technician can read the controller display and observe the intersection.

Connect detector test switches for cabinets as follows:

336S Cabinet		332 Cabinet	
Detector Call Switches	Terminals	Detector Call Switches	Terminals
Phase 1	I1-F	Phase 1	I1-W
Phase 2	I2-F	Phase 2	I4-W
Phase 3	I3-F	Phase 3	I5-W
Phase 4	I4-F	Phase 4	I8-W
Phase 5	I5-F	Phase 5	J1-W
Phase 6	I6-F	Phase 6	J4-W
Phase 7	I7-F	Phase 7	J5-W
Phase 8	I8-F	Phase 8	J8-W

Provide the PCB 28/56 connector for the conflict monitor unit (CMU) with 28 independent contacts per side, dual-sided with 0.156 inch contact centers. Provide the PCB 28/56 connector contacts with solder eyelet terminations. Ensure all connections to the PCB 28/56 connector are soldered to the solder eyelet terminations.

Ensure that all cabinets have the CMU connector wired according to the 332 cabinet connector pin assignments (include all wires for auxiliary output file connection). Wire pins 13, 16, R, and U of the CMU connector to a separate 4 pin plug, P1, as shown below. Provide a second plug, P2, which will mate with P1 and is wired to the auxiliary output file as shown below. Provide an additional plug, P3, which will mate with P1 and is wired to the pedestrian yellow circuits as shown below. When no auxiliary output file is installed in the cabinet, provide wires for the green and yellow inputs for channels 11, 12, 17, and 18, the red inputs for channels 17 and 18, and the wires for the P2 plug. Terminate the two-foot wires with ring type lugs, insulated, and bundled for optional use.

PIN	P1		P2		P3	
	FUNCTION	CONN TO	FUNCTION	CONN TO	FUNCTION	CONN TO
1	CH-9G	CMU-13	OLA-GRN	A123	2P-YEL	114
2	CH-9Y	CMU-16	OLA-YEL	A122	4P-YEL	105
3	CH-10G	CMU-R	OLB-GRN	A126	6P-YEL	120
4	CH-10Y	CMU-U	OLB-YEL	A125	8P-YEL	111

Do not provide the P20 terminal assembly (red monitor board) or red interface ribbon cable as specified in LA Specification No. 54-053-08.

Provide a P20 connector that mates with and is compatible with the red interface connector mounted on the front of the conflict monitor. Ensure that the P20 connector and the red interface

connector on the conflict monitor are center polarized to ensure proper connection. Ensure that removal of the P20 connector will cause the conflict monitor to recognize a latching fault condition and place the cabinet into flashing operation.

Wire the P20 connector to the output file and auxiliary output file using 22 AWG stranded wires. Ensure the length of these wires is a minimum of 42 inches in length. Provide a durable braided sleeve around the wires to organize and protect the wires.

Wire the P20 connector to the traffic signal red displays to provide inputs to the conflict monitor as shown below. Ensure the pedestrian Don't Walk circuits are wired to channels 13 through 16 of the P20 connector. When no auxiliary output file is installed in the cabinet, provide wires for channels 9 through 12 reds. Provide a wire for special function 1. Terminate the unused wires with ring type lugs, insulated, and bundled for optional use.

P20 Connector					
PIN	FUNCTION	CONN TO	PIN	FUNCTION	CONN TO
1	Channel 15 Red	119	2	Channel 16 Red	110
3	Channel 14 Red	104	4	Chassis GND	01-9
5	Channel 13 Red	113	6	N/C	
7	Channel 12 Red	AUX 101	8	Spec Function 1	
9	Channel 10 Red	AUX 124	10	Channel 11 Red	AUX 114
11	Channel 9 Red	AUX 121	12	Channel 8 Red	107
13	Channel 7 Red	122	14	Channel 6 Red	134
15	Channel 5 Red	131	16	Channel 4 Red	101
17	Channel 3 Red	116	18	Channel 2 Red	128
19	Channel 1 Red	125	20	Red Enable	01-14

Ensure the controller unit outputs to the auxiliary output file are pre-wired to the C5 connector. When no auxiliary output file is installed in the cabinet, connect the C5 connector to a storage socket located on the Input Panel or on the rear of the PDA.

Do not wire pin 12 of the load switch sockets.

In addition to the requirements of LA Specification No. 54-053-08, ensure relay K1 on the Power Distribution Assembly (PDA) is a four pole relay and K2 on the PDA is a two pole relay.

Provide a two pole, ganged circuit breaker for the flash bus circuit. Ensure the flash bus circuit breaker is an inverse time circuit breaker rated for 10 amps at 120 VAC with a minimum of 10,000 RMS symmetrical amperes short circuit current rating. Do not provide the auxiliary switch feature on the flash bus circuit breaker. Ensure the ganged flash bus circuit breaker is certified by the circuit breaker manufacturer to provide gang tripping operation.

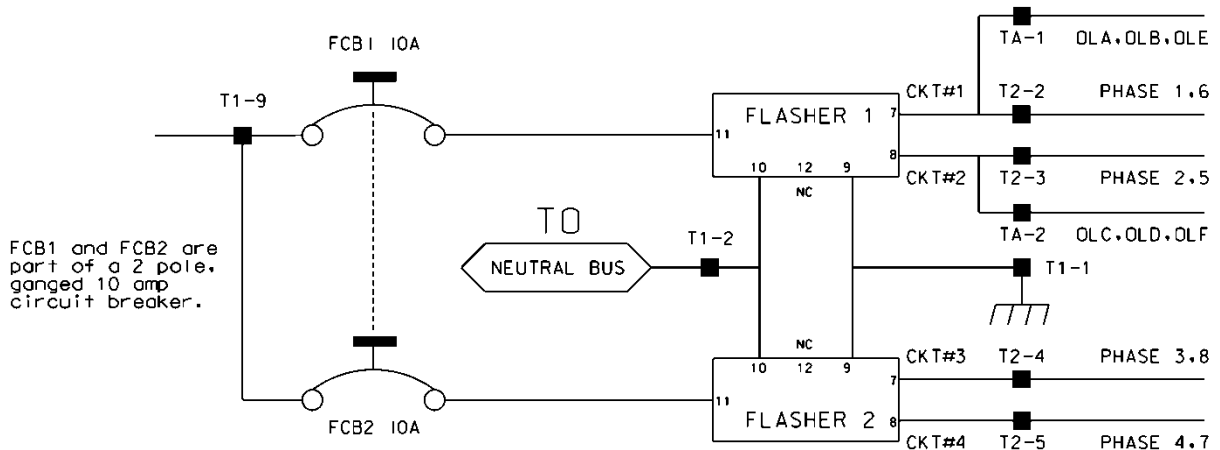

Ensure auxiliary output files are wired as follows:

AUXILIARY OUTPUT FILE	
TERMINAL BLOCK TA ASSIGNMENTS	
POSITION	FUNCTION
1	Flasher Unit #1, Circuit 1/FTR1 (OLA, OLB)/FTR3 (OLE)
2	Flasher Unit #1, Circuit 2/FTR2 (OLC, OLD)/FTR3 (OLF)
3	Flash Transfer Relay Coils
4	AC -
5	Power Circuit 5
6	Power Circuit 5
7	Equipment Ground Bus
8	NC

Provide four spare load resistors mounted in each cabinet. Ensure each load resistor is rated as shown in the table below. Wire one side of each load resistor to AC-. Connect the other side of each resistor to a separate terminal on a four (4) position terminal block. Mount the load resistors and terminal block either inside the back of Output File No. 1 or on the upper area of the Service Panel.

ACCEPTABLE LOAD RESISTOR VALUES	
VALUE (ohms)	WATTAGE
1.5K – 1.9 K	25W (min)
2.0K – 3.0K	10W (min)

Provide Model 200 load switches, Model 204 flashers, Model 242 DC isolators, Model 252 AC isolators, and Model 206L power supply units that conform to CALTRANS' *“Transportation Electrical Equipment Specifications”* dated March 12, 2009 with Erratum 1.

C. Type 170 E Cabinet Physical Requirements:

Do not mold, cast, or scribe the name “City of Los Angeles” on the outside of the cabinet door as specified in LA Specification No. 54-053-08. Do not provide a Communications Terminal Panel as specified in LA Specification No. 54-053-08. Do not provide terminal block TBB on the Service Panel. Do not provide Cabinet Verification Test Program software or associated test jigs as specified in LA Specification No. 54-053-08.

Furnish unpainted, natural, aluminum cabinet shells. Ensure that all non-aluminum hardware on the cabinet is stainless steel or a Department approved non-corrosive alternate.

Ensure the lifting eyes, gasket channels, police panel, and all supports welded to the enclosure and doors are fabricated from 0.125 inch minimum thickness aluminum sheet and meet the same standards as the cabinet and doors.

Provide front and rear doors with latching handles that allow padlocking in the closed position. Furnish 0.75 inch minimum diameter stainless steel handles with a minimum 0.5 inch shank. Place the padlocking attachment at 4.0 inches from the handle shank center to clear the lock and key. Provide an additional 4.0 inches minimum gripping length.

Provide Corbin #2 locks on the front and rear doors. Provide one (1) Corbin #2 and one (1) police master key with each cabinet. Ensure main door locks allow removal of keys in the locked position only.

Provide a surge protection panel with 16 loop surge protection devices and designed to allow sufficient free space for wire connection/disconnection and surge protection device replacement. For model 332 cabinets, provide an additional 20 loop surge protection devices. Provide an additional two AC+ interconnect surge devices to protect one slot and eight DC surge protection devices to

protect four slots. Provide no protection devices on slot I14.

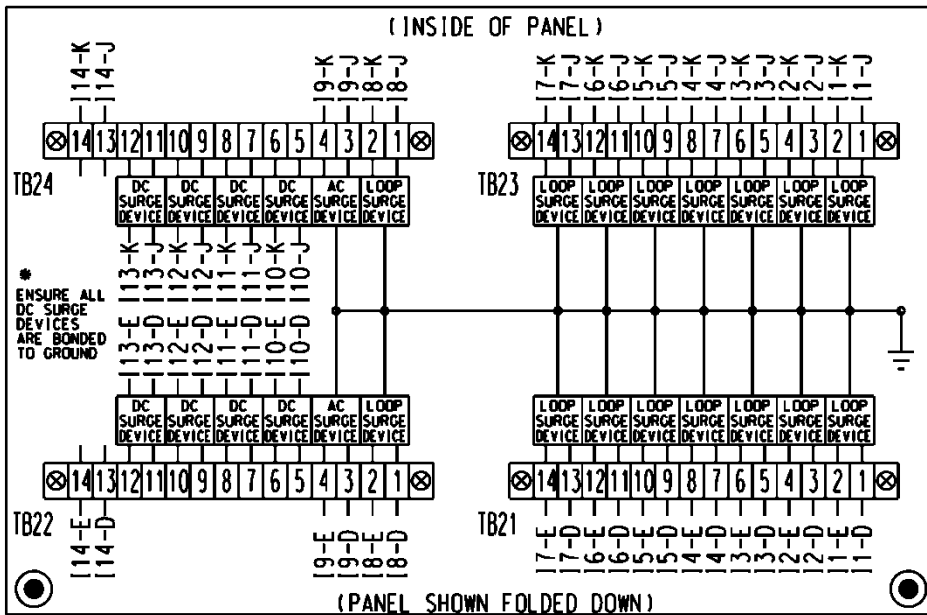
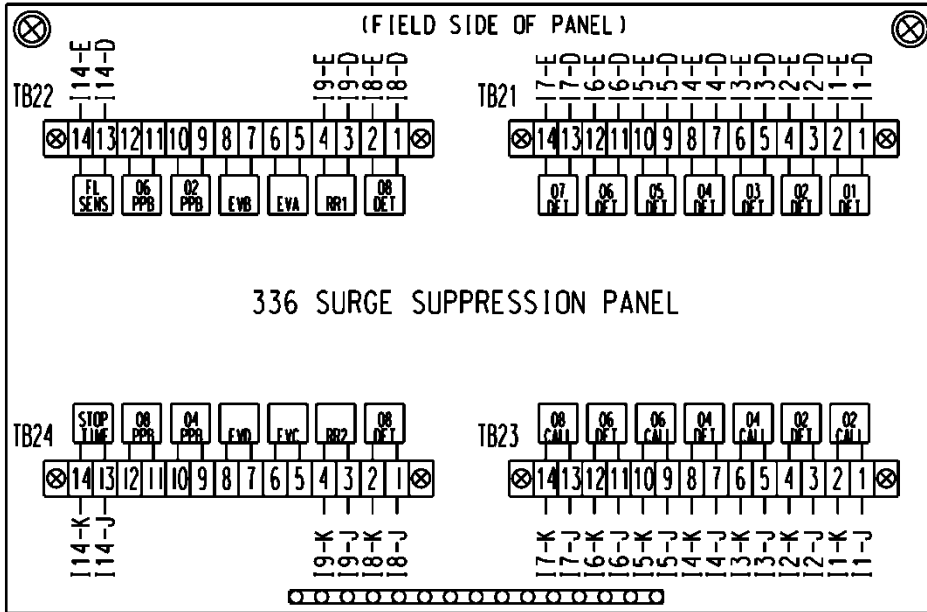

For base mounted cabinets, mount surge protection panels on the left side of the cabinet as viewed from the rear. Attach each panel to the cabinet rack assembly using bolts and make it easily removable. Mount the surge protection devices in vertical rows on each panel and connect the devices to one side of 12 position, double row terminal blocks with #8 screws. For each surge protection panel, terminate all grounds from the surge protection devices on a copper equipment ground bus attached to the surge protection panel. Wire the terminals to the rear of a standard input file using spade lugs for input file protection.

Provide permanent labels that indicate the slot and the pins connected to each terminal that may be viewed from the rear cabinet door. Label and orient terminals so that each pair of inputs is next to each other. Indicate on the labeling the input file (I or J), the slot number (1-14) and the terminal pins of the input slots (either D & E for upper or J & K for lower).

Provide a minimum 14 x 16 inch pull out, hinged top shelf located immediately below controller mounting section of the cabinet. Ensure the shelf is designed to fully expose the table surface outside the controller at a height approximately even with the bottom of the controller. Ensure the shelf has a storage bin interior which is a minimum of 1 inch deep and approximately the same dimensions as the shelf. Provide an access to the storage area by lifting the hinged top of the shelf. Fabricate the shelf and slide from aluminum or stainless steel and ensure the assembly can support the 2070L controller plus 15 pounds of additional weight. Ensure shelf has a locking mechanism to secure it in the fully extended position and does not inhibit the removal of the 2070L controller or removal of cards inside the controller when fully extended. Provide a locking mechanism that is easily released when the shelf is to be returned to its non-use position directly under the controller.

D. Model 2018 Enhanced Conflict Monitor:

Furnish Model 2018 Enhanced Conflict Monitors that provide monitoring of 18 channels. Ensure each channel consists of a green, yellow, and red field signal input. Ensure that the conflict monitor meets or exceeds CALTRANS' Transportation Electrical Equipment Specifications dated March 12, 2009, with Erratum 1 (hereafter referred to as CALTRANS' 2009 TEES) for a model 210 monitor unit and other requirements stated in this specification.

Ensure the conflict monitor is provided with an 18 channel conflict programming card. Pin EE and Pin T of the conflict programming card shall be connected together. Pin 16 of the conflict programming card shall be floating. Ensure that the absence of the conflict programming card will cause the conflict monitor to trigger (enter into fault mode), and remain in the triggered state until the programming card is properly inserted and the conflict monitor is reset.

Provide a conflict monitor that incorporates LED indicators into the front panel to dynamically display the status of the monitor under normal conditions and to provide a comprehensive review of field inputs with monitor status under fault conditions. Ensure that the monitor indicates the channels that were active during a conflict condition and the channels that experienced a failure for all other per channel fault conditions detected. Ensure that these indications and the status of each channel are retained until the Conflict Monitor is reset. Furnish LED indicators for the following:

- AC Power (Green LED indicator)
- VDC Failed (Red LED indicator)
- WDT Error (Red LED indicator)
- Conflict (Red LED indicator)
- Red Fail (Red LED indicator)
- Dual Indication (Red LED indicator)
- Yellow/Clearance Failure (Red LED indicator)
- PCA/PC Ajar (Red LED indicator)

- Monitor Fail/Diagnostic Failure (Red LED indicator)
- 54 Channel Status Indicators (1 Red, 1 Yellow, and 1 Green LED indicator for each of the 18 channels)

Provide a switch to set the Red Fail fault timing. Ensure that when the switch is in the ON position the Red Fail fault timing value is set to 1350 +/- 150 ms (2018 mode). Ensure that when the switch is in the OFF position the Red Fail fault timing value is set to 850 +/- 150 ms (210 mode).

Provide a switch to set the Watchdog fault timing. Ensure that when the switch is in the ON position the Watchdog fault timing value is set to 1.0 +/- 0.1 s (2018 mode). Ensure that when the switch is in the OFF position the Watchdog fault timing value is set to 1.5 +/- 0.1 s (210 mode).

Provide a jumper or switch to set the AC line brown-out levels. Ensure that when the jumper is present or the switch is in the ON position the AC line dropout voltage threshold is 98 +/- 2 Vrms, the AC line restore voltage threshold is 103 +/- 2 Vrms, and the AC line brown-out timing value is set to 400 +/- 50ms (2018 mode). Ensure that when the jumper is not present or the switch is in the OFF position the AC line dropout voltage threshold is 92 +/- 2 Vrms, the AC line restore voltage threshold is 98 +/- 2 Vrms, and the AC line brown-out timing value is set to 80 +/- 17 ms (210 mode).

Provide a jumper or switch that will enable and disable the Watchdog Latch function. Ensure that when the jumper is not present or the switch is in the OFF position the Watchdog Latch function is disabled. In this mode of operation, a Watchdog fault will be reset following a power loss, brownout, or power interruption. Ensure that when the jumper is present or the switch is in the ON position the Watchdog Latch function is enabled. In this mode of operation, a Watchdog fault will be retained until a Reset command is issued.

Provide a jumper that will reverse the active polarity for pin #EE (output relay common). Ensure that when the jumper is not present pin #EE (output relay common) will be considered 'Active' at a voltage greater than 70 Vrms and 'Not Active' at a voltage less than 50 Vrms (Caltrans mode). Ensure that when the jumper is present pin #EE (output relay common) will be considered 'Active' at a voltage less than 50 Vrms and 'Not Active' at a voltage greater than 70 Vrms (Failsafe mode).

In addition to the connectors required by CALTRANS' 2009 TEES, provide the conflict monitor with a red interface connector mounted on the front of the monitor. Ensure the connector is a 20 pin, right angle, center polarized, male connector with latching clip locks and polarizing keys. Ensure the right angle solder tails are designed for a 0.062" thick printed circuit board. Keying of the connector shall be between pins 3 and 5, and between 17 and 19. Ensure the connector has two rows of pins with the odd numbered pins on one row and the even pins on the other row. Ensure the connector pin row spacing is 0.10" and pitch is 0.10". Ensure the mating length of the connector pins is 0.24". Ensure the pins are finished with gold plating 30μ" thick.

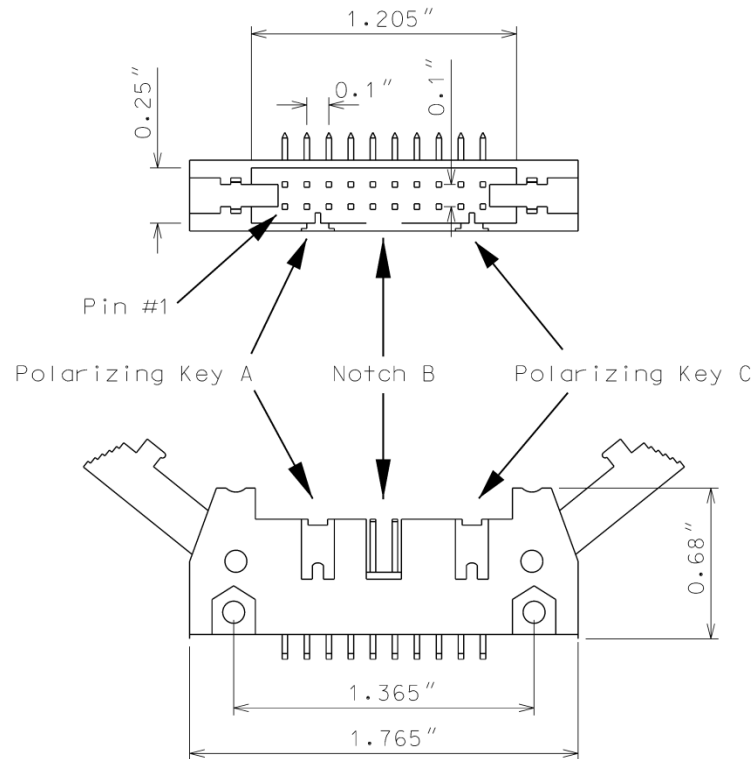

Ensure the red interface connector pins on the monitor have the following functions:

Pin #	Function	Pin #	Function
1	Channel 15 Red	2	Channel 16 Red
3	Channel 14 Red	4	Chassis Ground
5	Channel 13 Red	6	Special Function 2
7	Channel 12 Red	8	Special Function 1
9	Channel 10 Red	10	Channel 11 Red
11	Channel 9 Red	12	Channel 8 Red
13	Channel 7 Red	14	Channel 6 Red
15	Channel 5 Red	16	Channel 4 Red
17	Channel 3 Red	18	Channel 2 Red
19	Channel 1 Red	20	Red Enable

Ensure that removal of the P20 cable connector will cause the conflict monitor to recognize a latching fault condition and place the cabinet into flashing operation.

Provide Special Function 1 and Special Function 2 inputs to the unit which shall disable only Red Fail Monitoring when either input is sensed active. A Special Function input shall be sensed active when the input voltage exceeds 70 Vrms with a minimum duration of 550 ms. A Special Function input shall be sensed not active when the input voltage is less than 50 Vrms or the duration is less than 250 ms. A Special Function input is undefined by these specifications and may or may not be sensed active when the input voltage is between 50 Vrms and 70 Vrms or the duration is between 250 ms and 550 ms.

Ensure the conflict monitor recognizes field signal inputs for each channel that meet the following requirements:

- consider a Red input greater than 70 Vrms and with a duration of at least 500 ms as an “on” condition;
- consider a Red input less than 50 Vrms or with a duration of less than 200 ms as an “off” condition (no valid signal);
- consider a Red input between 50 Vrms and 70 Vrms or with a duration between 200 ms and 500 ms to be undefined by these specifications;
- consider a Green or Yellow input greater than 25 Vrms and with a duration of at least 500 ms as an “on” condition;
- consider a Green or Yellow input less than 15 Vrms or with a duration of less than 200 ms as an “off” condition; and
- consider a Green or Yellow input between 15 Vrms and 25 Vrms or with a duration between 200 ms and 500 ms to be undefined by these specifications.

Provide a conflict monitor that recognizes the faults specified by CALTRANS’ 2009 TEES and the following additional faults. Ensure the conflict monitor will trigger upon detection of a fault and will remain in the triggered (in fault mode) state until the unit is reset at the front panel or through the external remote reset input for the following failures:

1. **Red Monitoring or Absence of Any Indication (Red Failure):** A condition in which no “on” voltage signal is detected on any of the green, yellow, or red inputs to a given monitor channel. If a signal is not detected on at least one input (R, Y, or G) of a conflict monitor channel for a period greater than 1000 ms when used with a 170 controller and 1500 ms when used with a 2070 controller, ensure monitor will trigger and put the intersection into flash. If the absence of any indication condition lasts less than 700 ms when used with a 170 controller and 1200 ms when used with a 2070 controller, ensure conflict monitor will not trigger. Red fail monitoring shall be enabled on a per channel basis by the use of switches located on the conflict monitor. Have red monitoring occur when all of the following input conditions are in effect:
 - a) Red Enable input to monitor is active (Red Enable voltages are “on” at greater than 70 Vrms, off at less than 50 Vrms, undefined between 50 and 70 Vrms), and
 - b) Neither Special Function 1 nor Special Function 2 inputs are active.

- c) Pin #EE (output relay common) is not active
2. **Short/Missing Yellow Indication Fault (Clearance Error):** Yellow indication following a green is missing or shorter than 2.7 seconds (with ± 0.1 -second accuracy). If a channel fails to detect an “on” signal at the Yellow input for a minimum of 2.7 seconds (± 0.1 second) following the detection of an “on” signal at a Green input for that channel, ensure that the monitor triggers and generates a clearance/short yellow error fault indication. Short/missing yellow (clearance) monitoring shall be enabled on a per channel basis by the use of switches located on the conflict monitor. This fault shall not occur when the channel is programmed for Yellow Inhibit, when the Red Enable signal is inactive or pin #EE (output relay common) is active.
 3. **Dual Indications on the Same Channel:** In this condition, more than one indication (R,Y,G) is detected as “on” at the same time on the same channel. If dual indications are detected for a period greater than 500 ms, ensure that the conflict monitor triggers and displays the proper failure indication (Dual Ind fault). If this condition is detected for less than 200 ms, ensure that the monitor does not trigger. G-Y-R dual indication monitoring shall be enabled on a per channel basis by the use of switches located on the conflict monitor. G-Y dual indication monitoring shall be enabled for all channels by use of a switch located on the conflict monitor. This fault shall not occur when the Red Enable signal is inactive or pin #EE (output relay common) is active.
 4. **Configuration Settings Change:** The configuration settings are comprised of (as a minimum) the permissive diode matrix, dual indication switches, yellow disable jumpers, any option switches, any option jumpers, and the Watchdog Enable switch. Ensure the conflict monitor compares the current configuration settings with the previous stored configuration settings on power-up, on reset, and periodically during operation. If any of the configuration settings are changed, ensure that the conflict monitor triggers and causes the program card indicator to flash. Ensure that configuration change faults are only reset by depressing and holding the front panel reset button for a minimum of three seconds. Ensure the external remote reset input does not reset configuration change faults.

Ensure the conflict monitor will trigger and the AC Power indicator will flash at a rate of 2 Hz \pm 20% with a 50% duty cycle when the AC Line voltage falls below the “drop-out” level. Ensure the conflict monitor will resume normal operation when the AC Line voltage returns above the “restore” level. Ensure the AC Power indicator will remain illuminated when the AC voltage returns above the “restore” level. Should an AC Line power interruption occur while the monitor is in the fault mode, then upon restoration of AC Line power, the monitor will remain in the fault mode and the correct fault and channel indicators will be displayed.

Provide a flash interval of at least 6 seconds and at most 10 seconds in duration following a power-up, an AC Line interruption, or a brownout restore. Ensure the conflict monitor will suspend all fault monitoring functions, close the Output relay contacts, and flash the AC indicator at a rate of 4 Hz \pm 20% with a 50% duty cycle during this interval. Ensure the termination of the flash interval after at least 6 seconds if the Watchdog input has made 5 transitions between the True and False state and the AC Line voltage is greater than the “restore” level. If the watchdog input has not made

5 transitions between the True and False state within 10 ± 0.5 seconds, the monitor shall enter a WDT error fault condition.

Ensure the conflict monitor will monitor an intersection with a minimum of four approaches using the four-section Flashing Yellow Arrow (FYA) vehicle traffic signal as outlined by the NCHRP 3-54 research project for protected-permissive left turn signal displays. Ensure the conflict monitor will operate in the FYA mode and FYAc (Compact) mode as specified below to monitor each channel pair for the following fault conditions: Conflict, Flash Rate Detection, Red Fail, Dual Indication, and Clearance. Provide a switch to select between the FYA mode and FYAc mode. Provide a switch to select each FYA phase movement for monitoring.

FYA mode

FYA Signal Head	Phase 1	Phase 3	Phase 5	Phase 7
Red Arrow	Channel 9 Red	Channel 10 Red	Channel 11 Red	Channel 12 Red
Yellow Arrow	Channel 9 Yellow	Channel 10 Yellow	Channel 11 Yellow	Channel 12 Yellow
Flashing Yellow Arrow	Channel 9 Green	Channel 10 Green	Channel 11 Green	Channel 12 Green
Green Arrow	Channel 1 Green	Channel 3 Green	Channel 5 Green	Channel 7 Green

FYAc mode

FYA Signal Head	Phase 1	Phase 3	Phase 5	Phase 7
Red Arrow	Channel 1 Red	Channel 3 Red	Channel 5 Red	Channel 7 Red
Yellow Arrow	Channel 1 Yellow	Channel 3 Yellow	Channel 5 Yellow	Channel 7 Yellow
Flashing Yellow Arrow	Channel 1 Green	Channel 3 Green	Channel 5 Green	Channel 7 Green
Green Arrow	Channel 9 Green	Channel 9 Yellow	Channel 10 Green	Channel 10 Yellow

If a FYA channel pair is enabled for FYA operation, the conflict monitor will monitor the FYA logical channel pair for the additional following conditions:

1. **Conflict:** Channel conflicts are detected based on the permissive programming jumpers on the program card. This operation remains unchanged from normal operation except for the solid Yellow arrow (FYA clearance) signal.
2. **Yellow Change Interval Conflict:** During the Yellow change interval of the Permissive Turn channel (flashing Yellow arrow) the conflict monitor shall verify that no conflicting channels to the solid Yellow arrow channel (clearance) are active. These conflicting channels shall be determined by the program card compatibility programming of the Permissive Turn channel (flashing Yellow arrow). During the Yellow change interval of the Protected Turn channel (solid Green arrow) the conflict monitor shall verify that no conflicting channels to the solid Yellow arrow channel (clearance) are active as determined by the program card compatibility programming of the Protected Turn channel (solid Green arrow).
3. **Flash Rate Detection:** The conflict monitor unit shall monitor for the absence of a valid flash rate for the Permissive turn channel (flashing Yellow arrow). If the Permissive turn channel (flashing Yellow arrow) is active for a period greater than 1600 milliseconds, ensure the conflict monitor triggers and puts the intersection into flash. If the Permissive turn channel (flashing Yellow arrow) is active for a period less than 1400 milliseconds, ensure the conflict monitor does not trigger. Ensure the conflict monitor will remain in the triggered (in fault mode) state until the unit is reset at the front panel or through the external remote reset input. Provide a jumper or switch that will enable and disable the Flash Rate Detection function. Ensure that when the jumper is not present or the switch is in the OFF position the Flash Rate Detection function is enabled. Ensure that when the jumper is present or the switch is in the ON position the Flash Rate Detection function is disabled.
4. **Red Monitoring or Absence of Any Indication (Red Failure):** The conflict monitor unit shall detect a red failure if there is an absence of voltage on all four of the inputs of a FYA channel pair (RA, YA, FYA, GA).
5. **Dual Indications on the Same Channel:** The conflict monitor unit shall detect a dual indication if two or more inputs of a FYA channel pair (RA, YA, FYA, GA) are “on” at the same time.
6. **Short/Missing Yellow Indication Fault (Clearance Error):** The conflict monitor unit shall monitor the solid Yellow arrow for a clearance fault when terminating both the Protected Turn channel (solid Green arrow) interval and the Permissive Turn channel (flashing Yellow arrow) interval.

Ensure that the conflict monitor will log at least nine of the most recent events detected by the monitor in non-volatile EEPROM memory (or equivalent). For each event, record at a minimum the time, date, type of event, status of each field signal indication with RMS voltage, and specific channels involved with the event. Ensure the conflict monitor will log the following events: monitor reset, configuration, previous fault, and AC line. Furnish the signal sequence log that shows all channel states (Greens, Yellows, and Reds) and the Red Enable State for a minimum of 2 seconds prior to the current fault trigger point. Ensure the display resolution of the inputs for the signal sequence log is not greater than 50 ms.

For conflict monitors used within an Ethernet communications system, provide a conflict monitor with an Ethernet 10/100 Mbps, RJ-45 port for data communication access to the monitor by a local notebook computer and remotely via a workstation or notebook computer device connected to the signal system local area network. The Ethernet port shall be electrically isolated from the conflict monitor's electronics and shall provide a minimum of 1500 Vrms isolation. Integrate monitor with Ethernet network in cabinet. Provide software to retrieve the time and date from a network server in order to synchronize the on-board times between the conflict monitor and the controller. Furnish and install the following Windows based, graphic user interface software on workstations and notebook computers where the signal system client software is installed: 1) software to view and retrieve all event log information, 2) software that will search and display a list of conflict monitor IP addresses and IDs on the network, and 3) software to change the conflict monitor's network parameters such as IP address and subnet mask.

For non-Ethernet connected monitors, provide a RS-232C/D compliant port (DB-9 female connector) on the front panel of the conflict monitor in order to provide communications from the conflict monitor to the 170/2070 controller or to a Department-furnished laptop computer. Electrically isolate the port interface electronics from all monitor electronics, excluding Chassis Ground. Ensure that the controller can receive all event log information through a controller Asynchronous Communications Interface Adapter (Type 170E) or Async Serial Comm Module (2070). Furnish and connect a serial cable from the conflict monitor's DB-9 connector to Comm Port 1 of the 2070 controller. Ensure conflict monitor communicates with the controller. Provide a Windows based graphic user interface software to communicate directly through the same monitor RS-232C/D compliant port to retrieve and view all event log information to a Department-furnished laptop computer. The RS-232C/D compliant port on the monitor shall allow the monitor to function as a DCE device with pin connections as follows:

Conflict Monitor RS-232C/D (DB-9 Female) Pinout		
Pin Number	Function	I/O
1	DCD	O
2	TX Data	O
3	RX Data	I
4	DTR	I
5	Ground	-
6	DSR	O
7	CTS	I
8	RTS	O
9	NC	-

MONITOR BOARD EDGE CONNECTOR

Pin #	Function (Back Side)	Pin #	Function (Component Side)
1	Channel 2 Green	A	Channel 2 Yellow
2	Channel 13 Green	B	Channel 6 Green
3	Channel 6 Yellow	C	Channel 15 Green
4	Channel 4 Green	D	Channel 4 Yellow
5	Channel 14 Green	E	Channel 8 Green
6	Channel 8 Yellow	F	Channel 16 Green
7	Channel 5 Green	H	Channel 5 Yellow
8	Channel 13 Yellow	J	Channel 1 Green
9	Channel 1 Yellow	K	Channel 15 Yellow
10	Channel 7 Green	L	Channel 7 Yellow
11	Channel 14 Yellow	M	Channel 3 Green
12	Channel 3 Yellow	N	Channel 16 Yellow
13	Channel 9 Green	P	Channel 17 Yellow
14	Channel 17 Green	R	Channel 10 Green
15	Channel 11 Yellow	S	Channel 11 Green
16	Channel 9 Yellow	T	Channel 18 Yellow
17	Channel 18 Green	U	Channel 10 Yellow
--		--	
18	Channel 12 Yellow	V	Channel 12 Green
19	Channel 17 Red	W	Channel 18 Red
20	Chassis Ground	X	Not Assigned
21	AC-	Y	DC Common
22	Watchdog Timer	Z	External Test Reset
23	+24VDC	AA	+24VDC
24	Tied to Pin 25	BB	Stop Time (Output)
25	Tied to Pin 24	CC	Not Assigned
26	Not Assigned	DD	Not Assigned
27	Relay Output, Side #3, N.O.	EE	Relay Output, Side #2, Common
28	Relay Output, Side #1, N.C.	FF	AC+

-- Slotted for keying between Pins 17/U and 18/V

CONFLICT PROGRAM CARD PIN ASSIGNMENTS

Pin #	Function (Back Side)	Pin #	Function (Component Side)
1	Channel 2 Green	A	Channel 1 Green
2	Channel 3 Green	B	Channel 2 Green
3	Channel 4 Green	C	Channel 3 Green
4	Channel 5 Green	D	Channel 4 Green
5	Channel 6 Green	E	Channel 5 Green
6	Channel 7 Green	F	Channel 6 Green
7	Channel 8 Green	H	Channel 7 Green
8	Channel 9 Green	J	Channel 8 Green
9	Channel 10 Green	K	Channel 9 Green
10	Channel 11 Green	L	Channel 10 Green
11	Channel 12 Green	M	Channel 11 Green
12	Channel 13 Green	N	Channel 12 Green
13	Channel 14 Green	P	Channel 13 Green
14	Channel 15 Green	R	Channel 14 Green
15	Channel 16 Green	S	Channel 15 Green
16	N/C	T	PC AJAR
17	Channel 1 Yellow	U	Channel 9 Yellow
18	Channel 2 Yellow	V	Channel 10 Yellow
19	Channel 3 Yellow	W	Channel 11 Yellow
20	Channel 4 Yellow	X	Channel 12 Yellow
21	Channel 5 Yellow	Y	Channel 13 Yellow
22	Channel 6 Yellow	Z	Channel 14 Yellow
23	Channel 7 Yellow	AA	Channel 15 Yellow
24	Channel 8 Yellow	BB	Channel 16 Yellow
--		--	
25	Channel 17 Green	CC	Channel 17 Yellow
26	Channel 18 Green	DD	Channel 18 Yellow
27	Channel 16 Green	EE	PC AJAR (Program Card)
28	Yellow Inhibit Common	FF	Channel 17 Green

-- Slotted for keying between Pins 24/BB and 25/CC

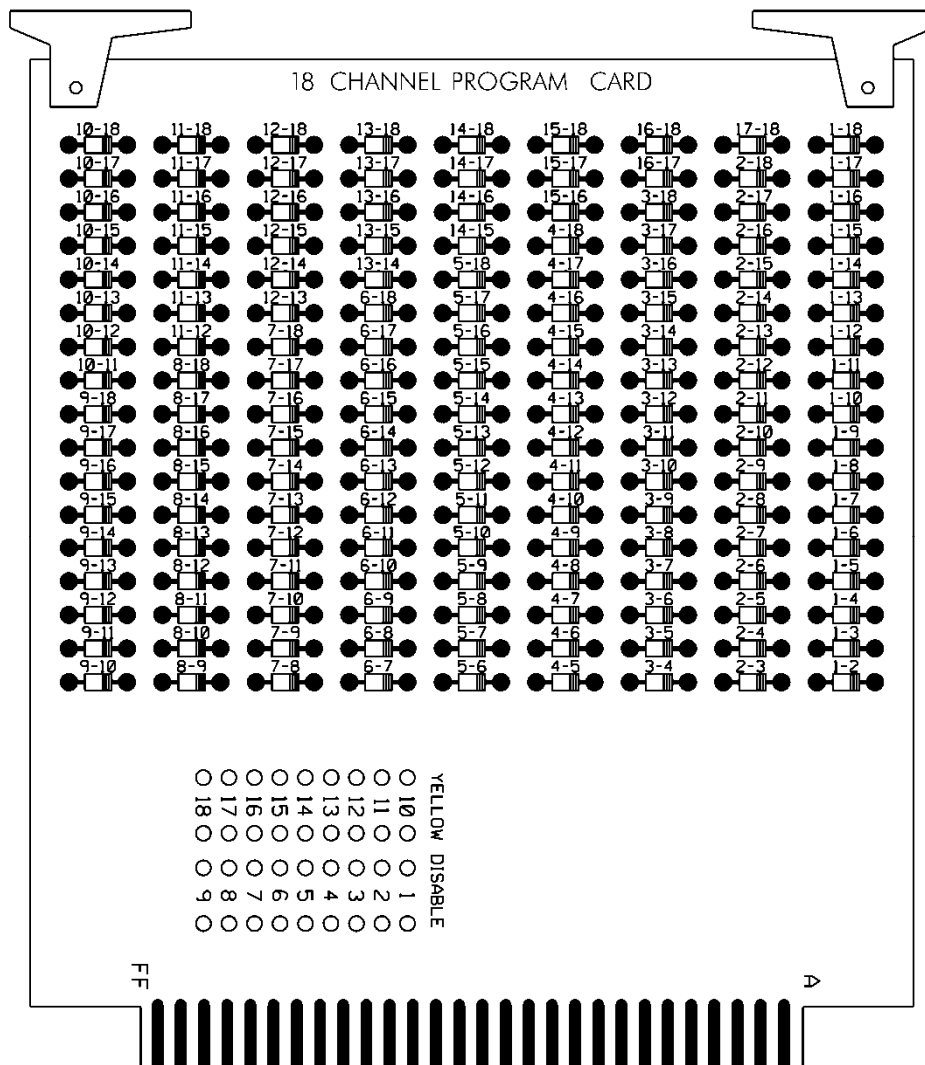

3.3. MATERIALS – TYPE 170 DETECTOR SENSOR UNITS

Furnish detector sensor units that comply with Chapter 5 Section 1, “General Requirements,” and Chapter 5 Section 2, “Model 222 & 224 Loop Detector Sensor Unit Requirements,” of the CALTRANS “Transportation Electrical Equipment Specifications” dated March 12, 2009 with Erratum 1.

3.4. MATERIALS – TYPE 2070E CONTROLLERS

Furnish model 2070E controller units that conform to CALTRANS *Transportation Electrical Equipment Specifications* (TEES) (dated March 12, 2009, plus Errata 1 dated January 21, 2010 and Errata 2 dated December 5, 2014) except as required herein.

The Department will provide software at the beginning of the burning-in period. Contractor shall give 5 working days notice before needing software. Program software provided by the Department.

Provide model 2070E controllers with OS-9 release 1.3.1 or later with kernel edition #380 or later operating software and device drivers, composed of the unit chassis and at a minimum the following modules and assemblies:

- MODEL 2070-1E, CPU Module, Single Board, with 8Mb Datakey (blue in color)
- MODEL 2070-2E+, Field I/O Module (FI/O)
 - Note: Configure the Field I/O Module to disable both the External WDT Shunt/Toggle Switch and SP3 (SP3 active indicator is “off”)
- MODEL 2070-3B, Front Panel Module (FP), Display B (8x40)
- MODEL 2070-4A, Power Supply Module, 10 AMP
- MODEL 2070-7A, Async Serial Com Module (9-pin RS-232)

4. VIDEO IMAGING LOOP EMULATOR DETECTOR SYSTEMS

4.1. DESCRIPTION

Design, furnish, provide training, and install video imaging loop emulator detection systems with all necessary hardware in accordance with the plans and specifications.

Unless otherwise specified in the contract, all loop emulator detection equipment will remain the property of the contractor.

4.2. MATERIALS

A. General:

Material and equipment furnished under this section must be pre-approved on the Department's QPL by the date of installation except miscellaneous hardware such as cables and mounting hardware do not need to be pre-approved.

Used equipment will be acceptable provided the following conditions have been met:

- Equipment is listed on the current QPL.
- Equipment is in good working condition.
- Equipment is to remain the property of the contractor.

Ensure that software is licensed for use by the Department and by any other agency responsible for maintaining or operating the loop emulation system. Provide the Department with a license to duplicate and distribute the software as necessary for design and maintenance support.

Design and furnish video imaging loop emulator detection systems that detect vehicles at signalized intersections by processing video images and providing detection outputs to the signal controller in real time (within 112 milliseconds of vehicle arrival).

Furnish all required camera sensor units, loop emulator processor units, hardware and software packages, cabling, poles, mast arms, harnesses, camera mounting assemblies, surge protection panels, grounding systems, messenger cable and all necessary hardware. Furnish systems that allow the display of detection zones superimposed on an image of the roadway on a Department-furnished monitor or laptop computer screen. Ensure detection zones can be defined and data entered using a simple keyboard or mouse and monitor, or using a laptop PC with software.

Provide design drawings showing design details and camera sensor unit locations for review and acceptance before installation. Provide mounting height and location requirements for camera sensor units on the design based on site survey. Design video imaging loop emulator detection systems with all necessary hardware. Indicate all necessary poles, spans, mast arms, luminaire arms, cables, camera mounting assemblies and hardware to achieve the required detection zones where

Department owned poles are not adequate to locate the camera sensor units. Do not design for the installation of poles in medians.

Obtain the Engineer's approval before furnishing video imaging loop emulator detection systems. The contractor is responsible for the final design of video imaging loop emulator detection systems. Review and acceptance of the designs by the Department does not relieve the contractor from the responsibility to provide fully functional systems and to ensure that the required detection zones can be provided.

Provide the ability to program each detection call (input to the controller) with the following functions:

- Full Time Delay – Delay timer is active continuously,
- Normal Delay – Delay timer is inhibited when assigned phase is green (except when used with TS 2 and 170/2070L controllers),
- Extend – Call is extended for this amount of time after vehicle leaves detection area,
- Delay Call/Extend Call – This feature uses a combination of full time delay and extend time on the same detection call. Ensure operation is as follows: Vehicle calls are received after the delay timer times out. When a call is detected, it is held until the detection area is empty and the programmed extend time expires. If another vehicle enters the detection area before the extend timer times out, the call is held and the extend time is reset. When the extend timer times out, the delay timer has to expire before another vehicle call can be received.

Provide the ability to program each detection zone as one of the following functions:

- Presence detector,
- Directional presence detector,
- Pulse detector,
- Directional pulse detector.

Ensure previously defined detector zones and configurations can be edited.

Provide each individual system with all the necessary equipment to focus and zoom the camera lenses without the need to enter the camera enclosure.

Provide systems that allow for the placement of at least 8 detection zones within the combined field of view of a single camera sensor unit. Provide a minimum of 8 detection outputs per camera.

Provide detection zones that can be overlapped. Ensure systems reliably detect vehicles when the horizontal distance from the camera sensor unit to the detection zone area is less than ten times the mounting height of the sensor. Ensure systems detect vehicles in multiple travel lanes.

Ensure systems can detect vehicle presence within a 98 to 102 percent accuracy (up to 2 percent of the vehicles missed and up to 2 percent of false detection) for clear, dry, daylight conditions, a 96 to 105 percent accuracy (up to 4 percent of the vehicles missed and up to 5 percent false detection) for dawn and dusk conditions, and a 96 percent accuracy (up to 4 percent of the vehicles missed) for night and adverse conditions (fog, snow, rain, etc.) using standard sensor optics and in the absence of occlusion.

Repair and replace all failed components within 72 hours.

The Department may conduct field-testing to ensure the accuracy of completed video imaging loop emulator detection systems.

B. Loop Emulator System:

Furnish loop emulator systems that receive and simultaneously process information from camera sensor units, and provides detector outputs to signal controllers.

Ensure systems provide the following:

- Operate in a typical roadside environment and meet the environmental specifications and are fully compatible with NEMA TS 1, NEMA TS 2, or Type 170/2070L controllers and cabinets,
- provide a “fail-safe” mode whereby failure of one or more of the camera sensor units or power failure of the loop emulator system will cause constant calls to be placed on the affected vehicle detection outputs to the signal controller,
- provide compensation for minor camera movement of up to 2 percent of the field of view at 400 feet without falsely detecting vehicles,
- process the video at a minimum rate of 30 times per second,
- provide separate wired connectors inside the controller cabinet for video recording each camera,
- provide remote video monitoring with a minimum refresh rate at 1 frame per second over a standard dial-up telephone line,
- provide remote video detection monitoring.

Furnish camera sensor units that comply with the following:

- have an output signal conforming to EIA RS-170 standard,
- have a nominal output impedance of 75 ohms,
- be immune to bright light sources, or have built in circuitry or protective devices to prevent damage to the sensor when pointed directly at strong light sources,
- be housed in a light colored environmental enclosure that is water proof and dust tight, and that conforms to NEMA-4 specifications or better,
- simultaneously monitor at least five travel lanes when placed at the proper mounting location with a zoom lens,
- have a sunshield attached to the environmental enclosure to minimize solar heating,
- meet FCC class B requirements for electromagnetic interference emissions,
- have a heater attached to the viewing window of the environmental enclosure to prevent ice and condensation in cold weather.

Where coaxial video cables and other cables are required between the camera sensor and other components located in the controller cabinet, furnish surge protection in the controller cabinet.

If furnishing coaxial communications cable comply with the following, as recommended by the approved loop emulator manufacturer:

- Number 20 AWG, solid bare copper conductor terminated with crimped-on BNC connectors (do not use BNC adapters) from the camera sensor to the signal controller cabinet.
- Number 22 AWG, stranded bare copper conductor terminated with crimped-on BNC connectors (do not use BNC adapters) from the camera sensor unit to the junction box, and within the signal controller cabinet.

Furnish power cable appropriately sized to meet the power requirements of the sensors. At a minimum, provide three conductor 120 VAC field power cable.

As determined during the site survey, furnish sensor junction boxes with nominal 6 x 10 x 6 inches dimensions at each sensor location. Provide terminal blocks and tie points for coaxial cable.

C. Video Imaging Loop Emulator System Support:

Furnish video imaging loop emulator systems with either a simple keyboard or a mouse with monitor and appropriate software, or with system software for use on department-owned laptop PCs. Ensure the system is Windows 2000 and Windows XP compatible.

Provide Windows 2000 and Windows XP compatible personal computer software, if needed, to provide remote video and video detection monitoring.

Ensure systems allow the user to edit previously defined detector configurations. When a vehicle is within a detection zone, provide for a change in color or intensity of the detection zone perimeter or other appropriate display changes on the Department-furnished monitor or laptop computer screen.

Provide cabling and interconnection hardware with 6-foot minimum length interconnection cable to interface with the system.

Provide all associated equipment manuals and documentation.

4.3. CONSTRUCTION METHODS

Arrange and conduct site surveys with the system manufacturer's representative and Department personnel to determine proper camera sensor unit selection and placement. Provide the Department at least 3 working days notice before conducting site surveys. Upon completion of the site surveys the Department will provide revised plans reflecting the findings of the site survey.

Before beginning work at locations requiring video imaging loop emulator detection systems, furnish system software. Upon activation of detection zones, provide detector configuration files. Ensure that up-to-date detection configuration files are furnished for various detection zone configurations that may be required for construction phasing.

Place into operation loop emulator detection systems. Configure loop emulator detection systems to achieve required detection in designated zones. Have a certified manufacturer's representative on site to supervise and assist with installation, set up, and testing of the system.

Install the necessary processing and communications equipment in the signal controller cabinet. Make all necessary modifications to install equipment, cabling harnesses, and camera sensor interface panels with surge suppression.

Perform modifications to camera sensor unit gain, sensitivity, and iris limits necessary to complete the installation.

Do not install camera sensor units on signal poles unless approved by the Engineer.

Install the necessary cables from each sensor to the signal controller cabinet along signal cabling routes. Install surge protection and terminate all cable conductors.

Relocate camera sensor units and reconfigure detection zones as necessary according to the plans for construction phases.

Provide at least 8 hours of training on the set up, operation, troubleshooting, and maintenance of the loop emulator detection system to a maximum of ten Department personnel. Arrange for training to be conducted by the manufacturer’s representative at an approved site within the Division responsible for administration of the project. Thirty days before conducting training submit a detailed course curriculum, draft manuals and materials, and resumes. Obtain approval of the submittal before conducting the training. At least one week before beginning training, provide three sets of complete documentation necessary to maintain and operate the system. Do not perform training until installation of loop emulator detection systems is complete.

4.4. MEASUREMENT AND PAYMENT

Actual number of site surveys, arranged, conducted, and accepted.

Actual number of luminaire arms for video systems furnished, installed, and accepted.

Actual number of cameras without internal loop emulator processing units furnished, installed, and accepted.

Actual number of external loop emulator processing units furnished, installed, and accepted.

Actual number of camera sensor units relocated with detection zones reconfigured installed, and accepted.

No measurement will be made of video imaging loop emulator system support or training, power and video cables, and trenching as these items will be considered incidental to furnishing and installing video imaging loop emulator detection systems.

Payment will be made under:

Site Survey	Each
Luminaire Arm for Video System	Each
Camera without Internal Loop Emulator Processing Unit.....	Each
External Loop Emulator Processing Unit	Each
Relocate Camera Sensor Unit	Each

5. TRAFFIC SIGNAL SUPPORTS

5.1. METAL TRAFFIC SIGNAL SUPPORTS – ALL POLES

A. General:

Furnish and install metal poles with mast arms, grounding systems, and all necessary hardware. The work covered by this special provision includes requirements for the design, fabrication, and installation of both standard and custom/site specifically designed metal traffic signal supports and associated foundations.

Provide metal traffic signal support systems that contain no guy assemblies, struts, or stay braces. Provide designs of completed assemblies with hardware that equals or exceeds AASHTO *Standard Specifications for Structural Supports for Highway Signs, Luminaires and Traffic Signals*

6th Edition, 2013 (hereafter called 6th Edition AASHTO), including the latest interim specifications. Provide assemblies with a round or near-round (18 sides or more) cross-section, or a multi sided cross section with no less than six sides. The sides may be straight, convex, or concave.

Pole heights shown on signal plans are estimated from available data for bid purposes. Prior to furnishing metal signal poles, use field measurements and adjusted cross-sections to determine whether pole heights are sufficient to obtain required clearances. If pole heights are not sufficient, the Contractor should immediately notify the Engineer of the required revised pole heights.

Ensure that metal signal poles permit cables to be installed inside poles and any required mast arms. For holes in the poles and arms used to accommodate cables, provide full-circumference grommets. Arm flange plate wire access holes should be deburred, non grommets, and oversized to fit around the 2” diameter grommets shaft flange plate wire access hole.

After fabrication, have steel poles, required mast arms, and all parts used in the assembly hot-dip galvanized per section 1076. Design structural assemblies with weep holes large enough and properly located to drain molten zinc during the galvanization process. Provide hot-dip galvanizing on structures that meets or exceeds ASTM Standard A-123. Provide galvanizing on hardware that meets or exceeds ASTM Standard A-153. Ensure that threaded material is brushed and retapped as necessary after galvanizing. Perform repair of damaged galvanizing that complies with the following:

Repair of GalvanizingArticle 1076-7

Standard Drawings for Metal Poles are available that supplement these project special provisions. These drawings are located on the Department’s website:

<https://connect.ncdot.gov/resources/safety/pages/ITS-Design-Resources.aspx>

Comply with article 1098-1B of the *2018 STANDARD SPECIFICATIONS FOR ROADS & STRUCTURES*, hereinafter referred to as the *Standard Specifications* for submittal requirements. Furnish shop drawings for approval. Provide the copies of detailed shop drawings for each type of structure as summarized below. Ensure that shop drawings include material specifications for each component and identify welds by type and size on the detail drawing only, not in table format. **Do not release structures for fabrication until shop drawings have been approved by NCDOT.** Provide an itemized bill of materials for all structural components and associated connecting hardware on the drawings.

Comply with article 1098-1A of the *Standard Specifications* for Qualified Products List (QPL) submittals. All shop drawings must include project location description, signal inventory number(s) and a project number or work order number on the drawings.

Summary of information required for metal pole review submittal:

Item	Hardcopy Submittal	Electronic Submittal	Comments / Special Instructions
Sealed, Approved Signal Plan/Loading Diagram	1	1	All structure design information needs to reflect the latest approved signal plans
Custom Pole Shop Drawings	4 sets	1 set	Show NCDOT inventory number(s), contractor’s name and relevant revision number in the title block. All drawings must have a unique <u>drawing</u>

			number for each project and identified for multiple pages.
Standard Pole Shop Drawings (from the QPL)	4 sets	1 set	Submit drawings on 11" x 17" format media. Show NCDOT inventory number(s), contractor's name and relevant revision number in the title block. All drawings must have a <u>unique drawing</u> number for each project and identified for multiple pages.
Structure Calculations	1 set	1 set	Not required for Standard QPL Poles
Standard Pole Foundation Drawings	1 set	1 set	Submit drawings on 11" x 17" format media. Submit a completed Standard Foundation Selection form for each pole using foundation table on Metal Pole Drawing M-8.
Custom Foundation Drawings	4 sets	1 set	Submit drawings on 11" x 17" format media. Show NCDOT inventory number(s), contractor's name and relevant revision number in the title block. All drawings must have a <u>unique drawing</u> number for each project and identified for multiple pages. If QPL Poles are used, include the corresponding QPL pole shop drawings with this submittal.
Foundation Calculations	1	1	Submit copies of LPILE input, output and pile tip deflection graph per Section 11.4 of this specification for each foundation. Not required for Standard QPL Poles
Soil Boring Logs and Report	1	1	Report should include a location plan and a soil classification report including soil capacity, water level, hammer efficiency, soil bearing pressure, soil density, etc. for each pole.

NOTE – All shop drawings and custom foundation design drawings must be sealed by a Professional Engineer licensed in the state of North Carolina. All geotechnical information must be sealed by either a Professional Engineer or geologist licensed in the state of North Carolina. Include a title block and revision block on the shop drawings and foundation drawings showing the NCDOT inventory number.

Shop drawings and foundation drawings may be submitted together or separately for approval. However, shop drawings must be approved before foundations can be reviewed. Foundation designs will be returned without review if the associated shop drawing has not been approved. Boring reports should include the following: Engineer's summary, boring location maps, soil classification per AASHTO Classification System, hammer efficiency, and Metal Pole Standard Foundation Selection Form. Incomplete submittals will be returned without review. The Reviewer has the right to request additional analysis and copies of the calculations to expedite the approval process.

B. Materials:

Fabricate metal pole and arm shaft from coil or plate steel to meet the requirements of ASTM A 595 Grade A tubes. For structural steel shapes, plates and bars use A572 Gr 50 min or ASTM A709 Gr 50 min. Provide pole and arm shafts that are round in cross section or multisided tubular shapes and have a uniform linear taper of 0.14 in/ft. Construct shafts from one piece of single ply plate or coil so there are no circumferential weld splices. Galvanize in accordance with AASHTO M 111 or an approved equivalent.

Use the submerged arc process or other NCDOT previously approved process suitable for pole shaft and arms to continuously weld pole shafts and arm shafts along their entire length. The longitudinal seam weld will be finished flush to the outside contour of the base metal. Ensure shafts have no circumferential welds except at the lower end joining the shaft to the pole base and arm base. Use full penetration groove welds with backing ring for all tube-to-transverse-plate connections in accordance with 6th Edition AASHTO. Provide welding that conforms to Article 1072-18 of the *Standard Specifications*, except that no field welding on any part of the pole will be permitted unless approved by a qualified engineer.

Refer to Metal Pole Standard Drawing Sheets M2 through M5 for fabrication details. Fabricate anchor bases and mast arm connecting plates from plate steel meeting, as a minimum, the requirements of ASTM A572 Gr 50, AASHTO M270 Gr 50, ASTM A709 Gr50, or an approved equivalent. Conform to the applicable bolt pattern and orientation as shown on Metal Pole Standard Drawing Sheet M2.

Ensure all hardware is galvanized steel or stainless steel. The Contractor is responsible for ensuring that the designer/fabricator specifies connecting hardware and/or materials that do not create a dissimilar metal corrosive reaction.

Provide a minimum of four (4) 1-1/2" diameter high strength bolts for connection between arm plate and pole plate. Increase number of bolts to six (6) 1-1/2" diameter high strength bolts when arm lengths are greater than 50'-0" long.

Unless otherwise required by the design, ensure each anchor rod is 2" diameter and 60" length. Provide 10" minimum thread projection at the top of the rod, and 8" minimum at the bottom of the rod. Use anchor rod assembly and drilled pier foundation materials that meet the *Foundations and Anchor Rod Assemblies for Metal Poles* provision.

For each structural bolt and other steel hardware, hot dip galvanizing shall conform to the requirements of AASHTO M 232 (ASTM A 153). Ensure end caps for poles or mast arms are constructed of cast aluminum conforming to Aluminum Alloy 356.0F.

Provide a circular anchor bolt lock plate that will be secured to the anchor bolts at the embedded end with 2 washers and 2 nuts. Provide a base plate template that matches the bolt circle diameter of the anchor bolt lock plate. Construct plates and templates from 1/4" minimum thick steel with a minimum width of 4". Galvanizing is not required for both plates.

Provide 4 heavy hex nuts and 4 flat washers for each anchor bolt. For nuts, use AASHTO M291 grade 2H, DH, or DH3 or equivalent material. For flat washers, use AASHTO M293 or equivalent material.

C. Construction Methods:

Erect signal support poles only after concrete has attained a minimum allowable compressive strength of 3000 psi. Install anchor rod assemblies in accordance with the *Foundations and Anchor Rod Assemblies for Metal Poles* provision.

For further construction methods, see construction methods for Metal Pole with Mast Arm.

Connect poles to grounding electrodes and bond them to the electrical service grounding electrodes.

For holes in the poles used to accommodate cables, install grommets before wiring pole or arm. Do not cut or split grommets.

Attach the terminal compartment cover to the pole by a sturdy chain or cable. Ensure the chain or cable is long enough to permit the cover to hang clear of the compartment opening when the cover is removed, and is strong enough to prevent vandalism. Ensure the chain or cable will not interfere with service to the cables in the pole base.

Attach cap to pole with a sturdy chain or cable. Ensure the chain or cable is long enough to permit the cap to hang clear of the opening when the cap is removed.

Perform repair of damaged galvanizing that complies with the *Standard Specifications*, Article 1076-7 "Repair of Galvanizing."

Install galvanized wire mesh around the perimeter of the base plate to cover the gap between the base plate and top of foundation for debris and pest control.

Install a 1/4" thick plate for concrete foundation tag to include: concrete grade, depth, diameter, and reinforcement sizes of the installed foundation.

5.2. METAL POLE UPRIGHTS (VERTICAL MEMBERS)

A. Materials:

- Provide tapered tubular shafts and fabricated of steel conforming to ASTM A-595 Grade A or an approved equivalent.
- Hot-dip galvanize poles in accordance with AASHTO M 111 or an approved equivalent.
- Have shafts that are continuously welded for the entire length by the submerged arc process, and with exposed welds ground or rolled smooth and flush with the base metal. Provide welding that conforms to Article 1072-18 of the *Standard Specification* except that no field welding on any part of the pole will be permitted.
- Have Shafts with no circumferential welds except at the lower end joining the shaft to the base.
- Have anchor bases for steel poles fabricated from plate steel meeting as a minimum the requirements of ASTM A572 Gr 50, AASHTO M270 Gr 50, ASTM A709 Gr 50, or an approved equivalent.

Provide a grounding lug(s) in the approximate vicinity of the messenger cable clamp for bonding and grounding messenger cable. Lugs must accept #4 or #6 AWG wire to bond messenger cables to the pole in order to provide an effective ground fault circuit path. Refer to Metal Pole Standard Drawing Sheet M6 for construction details.

Have poles permanently stamped above the hand holes with the identification tag details as shown on Metal Pole Standard Drawing Sheet M2.

Provide liquid tight flexible metal conduit (Type LFMC), liquid tight flexible nonmetallic conduit (Type LFNC), high density polyethylene conduit (Type HDPE), or approved equivalent to isolate conductors feeding luminaires.

Fabricate poles from a single piece of steel or aluminum with single line seam weld with no transverse butt welds. Fabrication of two ply pole shafts is unacceptable with the exception of fluted shafts. Provide tapers for all shafts that begin at base and that have diameters which decrease uniformly at the rate of not more than 0.14 inch per foot (11.7 millimeters per meter) of length.

Provide four anchor nuts and four washers for each anchor bolt. Ensure that anchor bolts have required diameters, lengths, and positions, and will develop strengths comparable to their respective poles.

Provide a terminal compartment with cover and screws in each pole that encompasses the hand hole and contains a 12-terminal barrier type terminal block. Provide two terminal screws with a removable shorting bar between them for each termination. Furnish terminal compartment covers attached to the pole by a sturdy chain or cable approved by the Engineer. Ensure that the chain or cable is long enough to permit the cover to hang clear of the compartment opening when the cover is removed, and is strong enough to prevent vandals from being able to disconnect the cover from the pole. Ensure that the chain or cable will not interfere with service to the cables in the pole base.

Install grounding lugs that will accept #4 or #6 AWG wire to electrically bond messenger cables to the pole. Refer to Metal Pole Standard Drawing Sheet M6 for construction details.

For each pole, provide a 1/2 inch minimum thread diameter, coarse thread stud and nut for grounding which will accommodate #6 AWG ground wire. Ensure that the lug is electrically bonded to the pole and is conveniently located inside the pole at the hand hole.

Provide a removable pole cap with stainless steel attachment screws for the top of each pole. Ensure that the cap is cast aluminum conforming to Aluminum Association Alloy 356.0F. Furnish cap attached to the pole with a sturdy chain or cable approved by the Engineer. Ensure that the chain or cable is long enough to permit the cap to hang clear of the pole-top opening when the cap is removed.

When required by the plans, furnish couplings 42 inches above the bottom of the base for mounting of pedestrian pushbuttons. Provide mounting points consisting of 1-1/2 inch internally threaded half-couplings that comply with the NEC and that are mounted within the poles. Ensure that couplings are essentially flush with the outside surfaces of the poles and are installed before any required galvanizing. Provide a threaded plug in each mounting point. Ensure that the surface of the plug is essentially flush with the outer end of the mounting point when installed and has a recessed hole to accommodate a standard wrench.

MAST ARM POLE SHAFTS

Ensure that allowable pole deflection does not exceed that allowed per 6th Edition AASHTO. Ensure that maximum angular rotation of the top of the mast arm pole does not exceed 1 degree 40 minutes (1°40').

B. Construction Methods:

Install metal poles, hardware, and fittings as shown on the manufacturer's installation drawings. Install metal poles so that when the pole is fully loaded it is within 1 degree 40 minutes (1°40') of vertical. Install poles with the manufacturer's recommended "rake." Use threaded leveling nuts to establish rake if required.

5.3. MAST ARMS

Provide pole plates and associated gussets and fittings for attachment of required mast arms. As part of each mast arm attachment, provide a cable passage hole in the pole to allow passage of signal cables from the pole to the arm.

Ensure that allowable mast arm deflection does not exceed that allowed per 6th Edition AASHTO. Also when arm is fully loaded, tip of the arm shall not go below the arm attachment point with the pole for all load conditions per 6th Edition AASHTO.

Furnish all arm plates and necessary attachment hardware, including bolts and brackets.

Provide two extra bolts for each arm.

Provide grommet holes on the arms to accommodate cables for the signals.

Provide arms with weatherproof connections for attaching to the shaft of the pole.

Provide hardware that is galvanized steel, stainless steel, or corrosive-resistant aluminum.

Provide a removable end cap with stainless steel attachment screws for the end of each mast arm. Ensure that the cap is cast aluminum conforming to Aluminum Association Alloy 356.0F. Furnish cap attached to the arm with a sturdy chain or cable approved by the Engineer. Ensure that the chain or cable is long enough to permit the cap to hang clear of the arm end opening when the cap is removed.

Comply with the following for Steel Luminaire Arms:

- In addition to tapered tube, luminaire arms may be standard weight black steel pipe conforming to ASTM A 53-90a, Type E or Type S, Grade B or an approved equivalent.
- Conform to the welding requirements of the steel poles.
- After all fabricating, cutting, punching, and welding are completed, luminaire arms should be hot-dipped galvanized inside and outside.
- In accordance with the National Electrical Code (NEC) Article 230.2(E), provide identification of the electrical source provider for the luminaire feeder circuit with contact information on a permanent label located in the pole hand hole in the vicinity of the feeder circuit raceway.

A. Materials:

After all fabricating, cutting, punching, and welding are completed, hot-dip galvanize the structure in accordance with the AASHTO M 111 or an approved equivalent.

B. Construction Methods:

Install horizontal-type arms with sufficient manufactured rise to keep arm from deflecting below the arm attachment height.

Attach cap to the mast arm with a sturdy chain or cable. Ensure that the chain or cable is long enough to permit the cap to hang clear of the arm opening when the cap is removed.

For mast arm poles, use full penetration welds with back-up ring at the pole base and at the arm base connection.

5.4. DRILLED PIER FOUNDATIONS FOR METAL TRAFFIC SIGNAL POLES

Analysis procedures and formulas shall be based on AASHTO 6th Edition, latest ACI code and the *Drilled Shafts: Construction Procedures and Design Methods* FHWA-NHI-10-016 manual. Design methods based on engineering publications or research papers needs to have prior approval from NCDOT. The Department reserves the right to accept or disapprove any method used for the analysis.

Use a Factor of Safety of 1.33 for torsion and 2.0 for bending for the foundation design.

Foundation design for lateral load shall not exceed 1" lateral deflection at top of foundation.

For lateral analysis, use LPILE Plus V6.0 or later. Inputs, results and corresponding graphs are to be submitted with the design calculations.

Skin Friction is to be calculated using the α -method for cohesive soils and the β -method for cohesion-less soils (**Broms method will not be accepted**). Detailed descriptions of the " α " and " β " methods can be found in *FHWA-NHI-10-016*.

Omit first 2.5ft for cohesive soils when calculating skin friction.

When hammer efficiency is not provided, assume a value of 0.70.

Design all custom foundations to carry the maximum capacity of each metal pole. For standard case strain poles only, if a custom foundation is designed, use the actual shear, axial and moment reactions from the Standard Foundation Selection Table shown on Standard Drawing No. M8.

When poor soil conditions are encountered which could create an excessively large foundation design, consideration may be given to allowing an exemption to the maximum capacity design. The contractor must gain approval from the engineer before reducing a foundation's capacity. On projects where poor soil is known to be present, it is advisable that the contractor consider getting foundations approved before releasing poles for fabrication.

Have the contractor notify the engineer if the proposed foundation is to be installed on a slope other than 8H: 1V or flatter.

A. Description:

Furnish and install foundations for NCDOT metal poles with all necessary hardware in accordance with the plans and specifications.

Metal Pole Standards have been developed and implemented by NCDOT for use at signalized intersections in North Carolina. If the plans call for a standard pole, then a standard foundation may be selected from the plans. However, the Contractor is not required to use a standard foundation. If the Contractor chooses to design a non-standard site-specific foundation for a standard pole or if the plans call for a non-standard site-specific pole, design the foundation to conform to the applicable provisions in the NCDOT Metal Pole Standard Drawings and Section B7 (Non-Standard Foundation Design) below. If non-standard site specific foundations are designed for standard QPL approved strain poles, the foundation designer must use the design moment specified by load case on Metal Pole Standard Drawing Sheet M8. Failure to conform to this requirement will be grounds for rejection of the design.

If the Contractor chooses to design a non-standard foundation for a standard pole and the soil test results indicate a standard foundation is feasible for the site, the Contractor will be paid the cost of the standard foundation (drilled pier and wing wall, if applicable). Any additional costs associated with a non-standard site-specific foundation including additional materials, labor and equipment will be considered incidental to the cost of the standard foundation. All costs for the non-standard foundation design will also be considered incidental to the cost of the standard foundation.

B. Soil Test and Foundation Determination:

1. General:

Drilled piers are reinforced concrete sections, cast-in-place against in situ, undisturbed material. Drilled piers are of straight shaft type and vertical.

Some standard drilled piers for supporting poles with mast arms may require wing walls to resist torsional rotation. Based upon this provision and the results of the required soil test, a drilled pier length and wing wall requirement may be determined and constructed in accordance with the plans.

For non-standard site-specific poles, the contractor-selected pole fabricator will determine if the addition of wing walls is necessary for the supporting foundations.

2. Soil Test:

Perform a soil test at each proposed metal pole location. Complete all required fill placement and excavation at each signal pole location to finished grade before drilling each boring. Soil tests performed that are not in compliance with this requirement may be rejected and will not be paid. Drill one boring to a depth of 26 feet within a 25 foot radius of each proposed foundation.

Perform standard penetration tests (SPT) in accordance with ASTM D 1586 at depths of 1, 2.5, 5, 7.5, 10, 15, 20 and 26 feet. Discontinue the boring if one of the following occurs:

- A total of 100 blows have been applied in any 2 consecutive 6-in. intervals.
- A total of 50 blows have been applied with < 3-in. penetration.

Describe each intersection as the “Intersection of (Route or SR #), (Street Name) and (Route or SR #), (Street Name), _____ County, Signal Inventory No. _____”. Label borings with “B- N, S, E, W, NE, NW, SE or SW” corresponding to the quadrant location within the intersection. Pole numbers should be made available to the Drill Contractor. Include pole numbers in the boring label if they are available. If they are not available, ensure the boring labels can be cross-referenced to corresponding pole numbers. For each boring, submit a legible (hand written or typed) boring log signed and sealed by a licensed Geologist or Professional Engineer registered in North Carolina. Include on each boring the SPT blow counts and N-values at each depth, depth of the boring, hammer efficiency, depth of water table and a general description of the soil types encountered using the AASHTO Classification System.

3. Standard Foundation Determination:

Use the following method for determining the Design N-value:

$$N_{AVG} = \frac{(N@1' + N@2.5' + \dots + N@Deepest \text{ Boring Depth})}{\text{Total Number of N-values}}$$

Total Number of N-values

$$Y = (N@1')^2 + (N@2.5')^2 + \dots\dots\dots (N@Deepest \text{ Boring Depth})^2$$

$$Z = (N@1' + N@2.5' + \dots\dots\dots N@Deepest \text{ Boring Depth})$$

$$N_{STD \text{ DEV}} = \left[\frac{(\text{Total Number of N-values} \times Y) - Z^2}{(\text{Total Number of N-values}) \times (\text{Total Number of N-values} - 1)} \right]^{0.5}$$

Design N-value equals lesser of the following two conditions:

$$N_{AVG} - (N_{STD \text{ DEV}} \times 0.45)$$

Or

$$\text{Average of First Four N-Values} = \frac{(N@1' + N@2.5' + N@5' + N@7.5')}{4}$$

Note: If less than 4 N-values are obtained because of criteria listed in Section 2 above, use average of N-values collected for second condition. Do not include the N-value at the deepest boring depth for above calculations if the boring is discontinued at or before the required boring depth because of criteria listed in Section 2 above. Use N-value of zero for weight of hammer or weight of rod. If N-value is greater than 50, reduce N-value to 50 for calculations.

If standard NCDOT strain poles are shown on the plans and the Contractor chooses to use standard foundations, determine a drilled pier length, "L," for each signal pole from the Standard Foundations Chart (sheet M 8) based on the Design N-value and the predominant soil type. For each standard pole location, submit a completed "Metal Pole Standard Foundation Selection Form" signed by the Contractor's representative. Signature on form is for verification purposes only. Include the Design N-value calculation and resulting drilled pier length, "L," on each form.

If non-standard site-specific poles are shown on the plans, submit completed boring logs collected in accordance with Section 2 (Soil Test) above along with pole loading diagrams from the plans to the contractor-selected pole fabricator to assist in the pole and foundation design.

If one of the following occurs, the Standard Foundations Chart shown on the plans may not be used and a non-standard foundation may be required. In such case, contact the Engineer.

- The Design N-value is less than 4.
- The drilled pier length, "L", determined from the Standard Foundations Chart, is greater than the depth of the corresponding boring.

In the case where a standard foundation cannot be used, the Department will be responsible for the additional cost of the non-standard foundation.

Foundation designs are based on level ground around the traffic signal pole. If the slope around the edge of the drilled pier is steeper than 8:1 (H:V) or the proposed foundation will be less than 10 feet from the top of an embankment slope, the Contractor is responsible for providing slope information to the foundation designer and to the Engineer so it can be considered in the design.

The “Metal Pole Standard Foundation Selection Form” may be found at:

<http://www.ncdot.gov/doh/preconstruct/highway/geotech/formdet/misc/MetalPole.pdf>

If assistance is needed, contact the Engineer.

4. Non-Standard Foundation Design:

Design non-standard foundations based upon site-specific soil test information collected in accordance with Section 2 (Soil Test) above. Design drilled piers for side resistance only in accordance with Section 4.6 of the *AASHTO Standard Specifications for Highway Bridges*. Use the computer software LPILE version-6.0 or later manufactured by Ensoft, Inc. to analyze drilled piers. Use the computer software gINT V8i or later manufactured by Bentley Systems, Inc. with the current NCDOT gINT library and data template to produce SPT boring logs. Provide a drilled pier foundation for each pole with a length and diameter that result in a horizontal lateral movement of less than 1 inch at the top of the pier and a horizontal rotational movement of less than 1 inch at the edge of the pier. Contact the Engineer for pole loading diagrams for standard poles to be used for non-standard foundation designs. Submit any non-standard foundation designs including drawings, calculations, and soil boring logs to the Engineer for review and approval before construction.

C. Drilled Pier Construction:

Construct drilled pier foundations in accordance with the *Foundations and Anchor Rod Assemblies for Metal Poles* provision.

5.5. CUSTOM DESIGN OF TRAFFIC SIGNAL SUPPORTS

A. General:

Design traffic signal supports with foundations consisting of metal poles with mast arms.

The lengths of the metal signal poles shown on the plans are estimated from available data for bid purposes. Determine the actual length of each pole from field measurements and adjusted cross-sections. Furnish the revised pole heights to the Engineer. Use all other dimensional requirements shown on the plans.

Ensure each pole includes an identification tag with information and location positions as defined on Metal Pole Standard Drawing Sheets M2, M3 and M4. All pole shaft tags must include the NCDOT Inventory number followed by the pole number shown on the traffic signal or ITS (non-signalized locations) plan.

Design all traffic signal support structures using the following 6th Edition AASHTO specifications:

- Design for a 50 year service life as recommended by Table 3.8.3-2.
- Use the wind pressure map developed from 3-second gust speeds, as provided in Article 3.8.
- Ensure signal support structures include natural wind gust loading and truck-induced gust loading in the fatigue design, as provided for in Articles 11.7.1.2 and 11.7.1.3, respectively. Designs need not consider periodic galloping forces.
- Assume the natural wind gust speed in North Carolina is 11.2 mph. For natural wind fatigue stress calculations, utilize a drag coefficient (C_d) computed for 11.2 mph wind velocity and not the basic wind speed velocity.
- Design for Category II fatigue, as provided for in Article 11.6, unless otherwise specified.

- Calculate all stresses using applicable equations from Section 5. The Maximum allowable stress ratios for all signal support designs are 0.9.
- Conform to article 10.4.2 and 11.8 for all deflection requirements.

Ensure that the design permits cables to be installed inside poles and mast arms.

Unless otherwise specified by special loading criteria, the computed surface area for ice load on signal heads is:

- 3-section, 12-inch, Surface area: 26.0 ft² (17.0 ft² without back plate)
- 4-section, 12-inch, Surface area: 32.0 ft² (21.0 ft² without back plate)
- 5-section, 12-inch, Surface area: 42.0 ft² (29.0 ft² without back plate)

The ice loading for signal heads defined above includes the additional surface area that back plates will induce. Special loading criteria may be specified in instances where back plates will not be installed on signal heads. Refer to the Loading Schedule on each Metal Pole Loading Diagram for revised signal head surface areas. The pole designer should revise ice loads accordingly in this instance. Careful examination of the plans when this is specified is important as this may impact sizing of the metal support structure and foundation design which could affect proposed bid quotes. All maximum stress ratios of 0.9 still apply.

Assume the combined minimum weight of a messenger cable bundle (including messenger cable, signal cable and detector lead-in cables) is 1.3 lbs/ft. Assume the combined minimum diameter of this cable bundle is 1.3 inches.

Ensure that designs provide a removable pole cap with stainless steel attachment screws for each pole top and mast arm end.

B. Metal Poles:

Submit design drawings for approval including pre-approved QPL pole drawings. Show all the necessary details and calculations for the metal poles including the foundation and connections. Include NCDOT inventory number on design drawings. Include as part of the design calculations the ASTM specification numbers for the materials to be used. Provide the types and sizes of welds on the design drawings. Include a Bill of Materials on design drawings. Ensure design drawings and calculations are signed, dated, and sealed by the responsible professional engineer licensed in the state of North Carolina. Immediately bring to the attention of the Engineer any structural deficiency that becomes apparent in any assembly or member of any assembly as a result of the design requirements imposed by these specifications, the plans, or the typical drawings. Said Professional Engineer is wholly responsible for the design of all poles and arms. Review and acceptance of these designs by the Department does not relieve the said Professional Engineer of his responsibility. **Do not fabricate the assemblies until receipt of the Department's approval of the design drawings.**

For mast arm poles, provide designs with provisions for pole plates and associated gussets and fittings for mast arm attachment. As part of each mast arm attachment, provide a grommeted 2" diameter hole on the shaft side of the connection to allow passage of the signal cables from the pole to the arm.

Where ice is present, assume wind loads as shown in Figure 3.9.4.2-3 of the 6th Edition AASHTO Specification for Group III loading.

Provide a grounding lug(s) in the approximate vicinity of the messenger cable clamp for bonding and grounding messenger cable. Lugs must accept #4 or #6 AWG wire to bond messenger cables to the pole in order to provide an effective ground fault circuit path. Refer to Metal Pole Standard Drawing Sheet M6 for construction details.

Design tapers for all pole shafts that begin at the base with diameters that decrease uniformly at the rate of 0.14 inch per foot of length.

Design a base plate on each pole. The minimum base plate thickness for all poles is determined by the following criteria:

Case 1 Circular or rectangular solid base plate with the upright pole welded to the top surface of base plate with full penetration butt weld, and where no stiffeners are provided. A base plate with a small center hole, which is less than 1/3 of the upright diameter, and located concentrically with the upright pole, may be considered as a solid base plate.

The magnitude of bending moment in the base plate, induced by the anchoring force of each anchor bolt is $M = (P \times D_1) / 2$, where

M = bending moment at the critical section of the base plate induced by one anchor bolt

P = anchoring force of each anchor bolt

D_1 = horizontal distance between the anchor bolt center and the outer face of the upright, or the difference between the bolt circle radius and the outside radius of the upright

Locate the critical section at the face of the anchor bolt and perpendicular to the bolt circle radius. The overlapped part of two adjacent critical sections is considered ineffective.

Case 2 Circular or rectangular base plate with the upright pole socketed into and attached to the base plate with two lines of fillet weld, and where no stiffeners are provided, or any base plate with a center hole that is larger in diameter than 1/3 of the upright diameter.

The magnitude of bending moment induced by the anchoring force of each anchor bolt is $M = P \times D_2$,

where P = anchoring force of each anchor bolt

D_2 = horizontal distance between the face of the upright and the face of the anchor bolt nut

Locate the critical section at the face of the anchor bolt top nut and perpendicular to the radius of the bolt circle. The overlapped part of two adjacent critical sections is considered ineffective.

If the base plate thickness calculated for Case 2 is less than Case 1, use the thickness calculated for Case 1.

The following additional owner requirements apply concerning pole base plates.

- Ensure that whichever case governs as defined above, the anchor bolt diameter is set to match the base plate thickness. If the minimum diameter required for the anchor bolt exceeds the thickness required for the base plate, set the base plate thickness equal to the required bolt diameter.

- For all metal poles with mast arms, use a full penetration groove weld with a backing ring to connect the pole upright component to the base. Refer to Metal Pole Standard Drawing Sheet M4.

Ensure that designs have anchor bolt holes with a diameter 1/4 inch larger than the anchor bolt diameters in the base plate.

Ensure that the anchor bolts have the required diameters, lengths, and positions, and will develop strengths comparable to their respective poles.

Provide designs with a 6 x 12-inch hand hole with a reinforcing frame for each pole.

Provide designs with a terminal compartment with cover and screws in each pole that encompasses the hand hole and contains provisions for a 12-terminal barrier type terminal block.

For each pole, provide designs with provisions for a 1/2 inch minimum thread diameter, coarse thread stud and nut for grounding which will accommodate a #6 AWG ground wire. Ensure the lug is electrically bonded to the pole and is conveniently located inside the pole at the hand hole.

When required, design couplings on the pole for mounting pedestrian pushbuttons at a height of 42 inches above the bottom of the base. Provide mounting points consisting of 1-1/2 inch internally threaded half-couplings that comply with the NEC that are mounted within the poles. Ensure the couplings are essentially flush with the outside surfaces of the poles and are installed before any required galvanizing. Provide a threaded plug for each half coupling. Ensure that the surface of the plug is essentially flush with the outer end of the mounting point when installed and has a recessed hole to accommodate a standard wrench.

C. Mast Arms:

Design all arm plates and necessary attachment hardware, including bolts and brackets as required by the plans.

Design for grommeted holes on the arms to accommodate the cables for the signals if specified.

Design arms with weatherproof connections for attaching to the shaft of the pole.

Always use a full penetration groove weld with a backing ring to connect the mast arm to the pole. Refer to Metal Pole Standard Drawing Sheet M5.

Capacity of tapped flange plate must be sufficient to develop the full capacity of the connecting bolts. In all cases the flange plate of both arm and shaft must be at least as thick as the arm connecting bolts are in diameter.

5.6. METAL SIGNAL POLE REMOVALS

A. Description:

Remove and dispose of existing metal signal poles including mast arms, and remove and dispose of existing foundations, associated anchor bolts, electrical wires and connections.

B. Construction Methods:

1. Foundations:

Remove and promptly dispose of the metal signal pole foundations including reinforcing steel, electrical wires, and anchor bolts to a minimum depth of two feet below the finished ground elevation. At the Contractor's option, remove the complete foundation.

2. Metal Poles:

Assume ownership of the metal signal poles, remove the metal signal poles, and promptly transport the metal signal poles from the project. Use methods to remove the metal signal poles and attached traffic signal equipment that will not result in damage to other portions of the project or facility. Repair damages that are a result of the Contractor's actions at no additional cost to the Department.

Transport and properly dispose of the materials.

Backfill and compact disturbed areas to match the finished ground elevation. Seed unpaved areas.

Use methods to remove the foundations that will not result in damage to other portions of the project or facility. Repair damages that are a result of the Contractor's actions at no cost to the Department.

5.7. POLE NUMBERING SYSTEM

A. New Poles

Attach an identification tag to each pole shaft and mast arm section as shown on Metal Pole Standard Drawing Sheet M2 "Typical Fabrication Details Common To All Metal Poles".

5.8. MEASUREMENT AND PAYMENT

Actual number of metal poles with single mast arms furnished, installed, and accepted.

Actual number of soil tests with SPT borings drilled furnished and accepted.

Actual volume of concrete poured in cubic yards of drilled pier foundation furnished, installed and accepted.

Actual number of designs for mast arms with metal poles furnished and accepted.

Actual number of metal signal pole foundations removed and disposed.

Actual number of metal signal poles removed and disposed.

No measurement will be made for foundation designs prepared with metal pole designs, as these will be considered incidental to designing signal support structures.

Payment will be made under:

Metal Pole with Single Mast Arm	Each
Soil Test	Each
Drilled Pier Foundation.....	Cubic Yard
Mast Arm with Metal Pole Design	Each
Metal Pole Foundation Removal	Each
Metal Pole Removal.....	Each

6. PROTECTIVE COATING FOR METAL POLES

6.1. DESCRIPTION

Protective coating for metal poles is a supplemental durable color coating that is applied to galvanized steel and aluminum traffic signal structures installed in locations where maintaining an aesthetic appearance is important. Powder Coating is the preferred supplemental protective coating process for coating galvanized steel and aluminum structures. However, for the purposes of this special provision, an Acrylic Primer and top coat paint system is included as an acceptable alternative when protective color coating is required.

Provide protective coating over galvanization for all steel poles including all necessary hardware in accordance with the plans and specifications. Any aluminum components do not need to be galvanized before application of protective coating.

6.2. MATERIALS

With the exception of aluminum components, furnish all metal poles with galvanic protection along with a tough and durable application of protective coating. Aluminum components shall have a durable powder coating application. Galvanization is not required for aluminum components.

Furnish pole caps that have a low gloss powder finish applied over a hot-dipped galvanized surface. Comply with the applicable provisions of Section 442-10 and 442-12 of the Standard Specifications.

Ensure the selected color for protective coating has been verified and approved by the Engineer prior to fabrication.

6.3. COATING SHOP APPROVAL

Approve the coating shop facility prior to the application of any coating process. Submit all requests, procedures, and documents electronically to:

- Mr. Brian Hunter, P.E., Chemical Testing Engineer
- bhunter@ncdot.gov

A) Submit a quality control procedure that the company has established to ensure a quality and durable coating. The quality control procedure shall contain at a minimum the following:

- Qualified / Certified personnel to manage the QC Program and to conduct Quality Control tests
- Qualified / certified coaters
- Source and type of powder
- How the powder will be stored
- Powder application facility (heated or unheated)
- Surface pre-treatment
- Surface preparation including profile
- Application methods
- Curing conditions (conventional or infrared)
- Curing Temperature
- Adhesion & Holiday Detection
- Repair Procedure
- Storage and protection of coated items
- Shipping and handling (packing, protection, and wrapping)

- B) Submit a powder certification from the manufacturer
- C) Submit the following to the Chemical Testing Engineer a minimum of four weeks prior to coating application.
1. Two test panels of ASTM A36 steel, $\frac{1}{4}$ or greater in thickness measuring 8 inches by 11 inches using the proposed color of the final coat; a powder coated over galvanized test panel and a powder coated over un-galvanized test panel.
 2. In addition, provide two (2) samples of the same or comparable material and thickness as production pieces. Ensure production piece replicas do not exceed twelve inches (12”) in length and width nor 50 pounds in weight.
 3. Submit all test panels with inspection reports and records according to Standard Specifications, Section 442, Section 1072, Section 1076, and Section 1080.
 4. Acceptance of the panels is determined by meeting the requirements of ASTM D-4541 of 800 psi for both galvanized and un-galvanized and production piece test panels.
 5. Send all panels to:

Materials and Tests Unit
1801 Blue Ridge Road
Raleigh, NC 27607
Attn: Chemical Testing Engineer

6.4. POWDER COATING

A. Galvanizing:

Galvanize steel products in accordance with Section 1076 of the Standard Specifications. Ensure the fabricator or designated representative(s) that is supplying the components to be galvanized communicates with the galvanizer to indicate that the galvanized pieces will be powder coated to avoid water or chromate quenching.

B. Surface Preparation:

Comply with manufacturer’s recommended surface coating specifications, Steel Structure Painting Council (SSPC) specifications and applicable articles of Section 442 (Painting Steel Structures) of the Standard Specifications. Ensure that surface preparations and treatments are performed and meet the requirements of the above referenced specifications.

Some pole components, specifically steel plates $\frac{3}{4}$ inches or more in thickness, may need blast cleaning prior to structure assembly to remove impurities and non-metallic foreign materials. Mechanically remove all weld flux after structure is assembled

Degrease and prepare steel structure for zinc coating after assembly using full immersion baths and pickling processes in heat controlled caustic and acid solutions. Rinse and clean structure to remove caustic or acid solutions by immersion in a circulating fresh water bath. Immerse structure in a heat controlled concentrated zinc ammonium chloride flux solution and air dry as a final prep before hot-dip galvanization.

Ensure that the surface preparation is no less than specified by the powder manufacturer’s recommendations. Prepare all components to be coated in accordance with SSPC SP-2 (Hand Tool Cleaning) and/or SSPC SP-3 (Power Tool Cleaning). Remove all drainage spikes, high spots, protrusions, or other surface defects using hand or power tools. Do not remove the galvanization below the limits set forth in AASHTO M111.

Remove grease, oils, moisture, scale, rust, or any other foreign matter prior to powder coating to ensure ideal adhesion and coating performance. Prepare and coat the galvanized surface as soon as possible after the galvanization process.

C. Powder Coating Application and Curing:

Prepare galvanized finish for powder coating by brush blasting in accordance with SSPC-SP7. Ensure all threaded components of the structure are protected from damage during blasting process.

Use thermosetting powder resin that meets 5A or 5B classifications of ASTM D3359. Apply powder coating electrostatically. Follow manufacturer's recommended preheating requirements. Ensure the top coat finish is applied uniformly to all surfaces with a dry film thickness of between 3.0 to 5.0 mils. Cure the top coat by heating the structure to manufacturer recommended temperatures at the duration required to ensure complete and uniform bond.

D. Quality Control:

Ensure the applicator provides all test reports and documentation and inspects all coated material as outlined in the Standard Specifications, Section 442, Section 1072, Section 1076, and Section 1080. Ensure the quality control inspection is kept separate from the production functions.

E. Storage, Shipping, and Handling:

Store all powder coated material inside or as directed by the Engineer.

Protect the product from incurring damage during all shipping, handling, and storing activities. Do not store the product directly on the ground or in areas where water may pool; the Engineer determines the effectiveness of all storage, shipping, and handling methods.

F. Repair of Powder Coated Material:

Repair all damage to the coating by the original method of application as outlined in the coating facility's repair procedure. Ensure all repair areas meet the original requirements for adhesion as stated in this Project Special Provision.

Photograph, document, and report all damages upon delivery to the project site prior to unloading. Provide documented damage notifications to the Engineer or to their authorized representative so the application firm can be notified. The Engineer has the authority to accept or reject the material as outlined in the Standard Specifications.

Submit to the Engineer a repair procedure for damaged coatings which occur during storage, transporting, handling and or installation. Utilize a liquid paint approved by the Department, compatible with the powder applied product. Ensure all repair areas demonstrate an adhesion rating of 400 psi in accordance with ASTM D-4541. Obtain Engineer's acceptance of the final finish.

6.5. ACRYLIC PRIMER AND TOP COAT PAINT SYSTEM 4 (MODIFIED)

A. Description:

Follow NCDOT procedures for Powder Coating over Galvanizing. Provide an Acrylic Primer and top coat when a substitute for powder coating is necessary.

Provide supplemental coating for all mast arms with metal signal poles and all necessary hardware for the signalized intersection in accordance with NCDOT Standard specifications – sections 442 and 1080, as contained herein, and as shown on the plans.

Ensure all painting work for new structures, except field touch-up and bolt painting is performed in the shop.

B. Surface Preparation:

Ensure all surface preparation is not less than that specified by the paint manufacturer's recommendations.

Ensure all components to be coated are prepared in accordance with SSPC SP2 (Hand Tool Cleaning and or SSPC SP-3 (Power Tool Cleaning). Remove all drainage spikes, high spots, protrusions, or other surface defects using hand or power tools. Do not remove the galvanization below the limits set forth in AASHTO M111.

Perform abrasive sweep blasting in accordance with ASTM D6386. Refer to this section for a description of the abrasive blast material to be used. Use a material and technique capable of stripping action to remove corrosion products and to provide a rough surface profile while leaving base zinc layers intact.

Blow down all blasted surfaces with clean compressed air to provide a clean, dry surface.

Ensure all surfaces are free of visible zinc oxides or zinc hydroxides.

C. Materials:

Use an approved/qualified waterborne paint meeting the requirements of NCDOT Standard specification section 1080. Do not apply paint until each batch has been tested by the Department. Provide color as specified in the contract documents.

Ensure all paint used on this contract is produced by the same manufacturer.

D. Painting:

Apply paint in accordance with the requirements of Section 1080 and Section 442 of the 2010 Standard Specifications using System 4 as modified herein.

System 4 (Modified) Acrylic Primer and Top Coats

Coat	Material	Mils Dry/Wet Film Thickness	Mils Dry/Wet Film Thickness
		Minimum	Maximum
Primer	1080-12 White	3.0 DFT	5.0 DFT
Stripe	1080-12 Brown	4.0 WFT	7.0 WFT
Topcoat	1080-12 Brown	2.0 DFT	4.0 DFT
Total		5.0 DFT	9.0 DFT

Shop paint all galvanized surfaces within 8 hours after surface preparation with the exception of field touch-up and bolt painting.

Mask off and do not paint all data plates and faying surfaces prior to application.

Spray apply all coatings except for the stripe coat. Brush apply the stripe coat to all plate edges, welds, bolt holes and bolts prior to applying the finish coat.

E. Curing:

Store all material in a heated shop for a period no less than 24 hours once top coat has been applied. Continue storing material until requirements of ASTM D-1640 have been met.

F. Inspection:

Provide inspection records showing the initial average thickness of the hot dipped galvanizing as well as the final average DFT measurement.

Ensure all material is of a uniform appearance free of runs, drips, and sags.

G. Handling:

Do not handle, ship, or erect coated members until paint is thoroughly dry.

Protect all shipping and handling either from the coating facility to project site and or storage site to area(s) to construction location from incurring damage to product. Wood blocks and nylon slings are recommended for securing, loading, hoisting, or storing members.

H. Repair of Damaged Coating:

Repair damage occurring to the galvanized portion of the coating during shipment or installation in accordance with Articles 1076-6 and 1080-9 of the Standard Specifications. Repair damage occurring to the painted portion of the coating during shipment or installation by applying 4.0-7.0 wet mils of topcoat with a brush or roller and feather or taper this to be level with the surrounding areas.

6.6. MEASUREMENT AND PAYMENT

Actual number of single mast arm poles with protective coating applied furnished, installed, and accepted.

Actual number of pushbutton posts with protective coating applied furnished, installed, and accepted.

Payment will be made under:

Pay Item	Pay Unit
Protective Coating for Single Mast Arm Pole (Black)	Each
Protective Coating for Pushbutton Post (Black)	Each

R-5734A

ST-1

Macon County



R-5734A

Macon County, NC

Project Special Provisions

5/21/2018



DocuSigned by:
Nicholas D'Auto
D3C1506E749A49C...



TABLE OF CONTENTS

Provision		Page #
1. FALSEWORK AND FORMWORK	(4-5-12)	3
2. CRANE SAFETY	(8-15-05)	9
3. GROUT FOR STRUCTURES	(12-1-17)	10
4. SUBMITTAL OF WORKING DRAWINGS	(6-28-17)	11

FALSEWORK AND FORMWORK**(4-5-12)****1.0 DESCRIPTION**

Use this Special Provision as a guide to develop temporary works submittals required by the Standard Specifications or other provisions; no additional submittals are required herein. Such temporary works include, but are not limited to, falsework and formwork.

Falsework is any temporary construction used to support the permanent structure until it becomes self-supporting. Formwork is the temporary structure or mold used to retain plastic or fluid concrete in its designated shape until it hardens. Access scaffolding is a temporary structure that functions as a work platform that supports construction personnel, materials, and tools, but is not intended to support the structure. Scaffolding systems that are used to temporarily support permanent structures (as opposed to functioning as work platforms) are considered to be falsework under the definitions given. Shoring is a component of falsework such as horizontal, vertical, or inclined support members. Where the term “temporary works” is used, it includes all of the temporary facilities used in bridge construction that do not become part of the permanent structure.

Design and construct safe and adequate temporary works that will support all loads imposed and provide the necessary rigidity to achieve the lines and grades shown on the plans in the final structure.

2.0 MATERIALS

Select materials suitable for temporary works; however, select materials that also ensure the safety and quality required by the design assumptions. The Engineer has authority to reject material on the basis of its condition, inappropriate use, safety, or nonconformance with the plans. Clearly identify allowable loads or stresses for all materials or manufactured devices on the plans. Revise the plan and notify the Engineer if any change to materials or material strengths is required.

3.0 DESIGN REQUIREMENTS**A. Working Drawings**

Provide working drawings for items as specified in the contract, or as required by the Engineer, with design calculations and supporting data in sufficient detail to permit a structural and safety review of the proposed design of the temporary work.

On the drawings, show all information necessary to allow the design of any component to be checked independently as determined by the Engineer.

When concrete placement is involved, include data such as the drawings of proposed sequence, rate of placement, direction of placement, and location of all construction joints. Submit the number of copies as called for by the contract.

When required, have the drawings and calculations prepared under the guidance of, and sealed by, a North Carolina Registered Professional Engineer who is knowledgeable in temporary works design.

R-5734A

ST-4

Macon County

If requested by the Engineer, submit with the working drawings manufacturer's catalog data listing the weight of all construction equipment that will be supported on the temporary work. Show anticipated total settlements and/or deflections of falsework and forms on the working drawings. Include falsework footing settlements, joint take-up, and deflection of beams or girders.

As an option for the Contractor, overhang falsework hangers may be uniformly spaced, at a maximum of 36 inches, provided the following conditions are met:

Member Type (PCG)	Member Depth, (inches)	Max. Overhang Width, (inches)	Max. Slab Edge Thickness, (inches)	Max. Screenshot Wheel Weight, (lbs.)	Bracket Min. Vertical Leg Extension, (inches)
II	36	39	14	2000	26
III	45	42	14	2000	35
IV	54	45	14	2000	44
MBT	63	51	12	2000	50
MBT	72	55	12	1700	48
FIB	45	42	14	2000	35

Overhang width is measured from the centerline of the girder to the edge of the deck slab.

For Type II, III, IV & Florida I-Beam prestressed concrete girders (PCG), 45-degree cast-in-place half hangers and rods must have a minimum safe working load of 6,000 lbs.

For MBT prestressed concrete girders, 45-degree angle holes for falsework hanger rods shall be cast through the girder top flange and located, measuring along the top of the member, 1'-2½" from the edge of the top flange. Hanger hardware and rods must have a minimum safe working load of 6,000 lbs.

The overhang bracket provided for the diagonal leg shall have a minimum safe working load of 3,750 lbs. The vertical leg of the bracket shall extend to the point that the heel bears on the girder bottom flange, no closer than 4 inches from the bottom of the member. However, for 72-inch members, the heel of the bracket shall bear on the web, near the bottom flange transition.

Provide adequate overhang falsework and determine the appropriate adjustments for deck geometry, equipment, casting procedures and casting conditions.

If the optional overhang falsework spacing is used, indicate this on the falsework submittal and advise the girder producer of the proposed details. Failure to notify the Engineer of hanger type and hanger spacing on prestressed concrete girder casting drawings may delay the approval of those drawings.

Falsework hangers that support concentrated loads and are installed at the edge of thin top flange concrete girders (such as bulb tee girders) shall be spaced so as not to exceed 75% of the manufacturer's stated safe working load. Use of dual leg hangers (such as

Meadow Burke HF-42 and HF-43) are not allowed on concrete girders with thin top flanges. Design the falsework and forms supporting deck slabs and overhangs on girder bridges so that there will be no differential settlement between the girders and the deck forms during placement of deck concrete.

When staged construction of the bridge deck is required, detail falsework and forms for screed and fluid concrete loads to be independent of any previous deck pour components when the mid-span girder deflection due to deck weight is greater than $\frac{3}{4}$ ".

Note on the working drawings any anchorages, connectors, inserts, steel sleeves or other such devices used as part of the falsework or formwork that remains in the permanent structure. If the plan notes indicate that the structure contains the necessary corrosion protection required for a Corrosive Site, epoxy coat, galvanize or metalize these devices. Electroplating will not be allowed. Any coating required by the Engineer will be considered incidental to the various pay items requiring temporary works.

Design falsework and formwork requiring submittals in accordance with the 1995 AASHTO *Guide Design Specifications for Bridge Temporary Works* except as noted herein.

1. Wind Loads

Table 2.2 of Article 2.2.5.1 is modified to include wind velocities up to 110 mph. In addition, Table 2.2A is included to provide the maximum wind speeds by county in North Carolina.

Table 2.2 - Wind Pressure Values

Height Zone feet above ground	Pressure, lb/ft ² for Indicated Wind Velocity, mph				
	70	80	90	100	110
0 to 30	15	20	25	30	35
30 to 50	20	25	30	35	40
50 to 100	25	30	35	40	45
over 100	30	35	40	45	50

2. Time of Removal

The following requirements replace those of Article 3.4.8.2.

Do not remove forms until the concrete has attained strengths required in Article 420-16 of the Standard Specifications and these Special Provisions.

Do not remove forms until the concrete has sufficient strength to prevent damage to the surface.

R-5734A

ST-6

Macon County

Table 2.2A - Steady State Maximum Wind Speeds by Counties in North Carolina

COUNTY	25 YR (mph)	COUNTY	25 YR (mph)	COUNTY	25 YR (mph)
Alamance	70	Franklin	70	Pamlico	100
Alexander	70	Gaston	70	Pasquotank	100
Alleghany	70	Gates	90	Pender	100
Anson	70	Graham	80	Perquimans	100
Ashe	70	Granville	70	Person	70
Avery	70	Greene	80	Pitt	90
Beaufort	100	Guilford	70	Polk	80
Bertie	90	Halifax	80	Randolph	70
Bladen	90	Harnett	70	Richmond	70
Brunswick	100	Haywood	80	Robeson	80
Buncombe	80	Henderson	80	Rockingham	70
Burke	70	Hertford	90	Rowan	70
Cabarrus	70	Hoke	70	Rutherford	70
Caldwell	70	Hyde	110	Sampson	90
Camden	100	Iredell	70	Scotland	70
Carteret	110	Jackson	80	Stanley	70
Caswell	70	Johnston	80	Stokes	70
Catawba	70	Jones	100	Surry	70
Cherokee	80	Lee	70	Swain	80
Chatham	70	Lenoir	90	Transylvania	80
Chowan	90	Lincoln	70	Tyrell	100
Clay	80	Macon	80	Union	70
Cleveland	70	Madison	80	Vance	70
Columbus	90	Martin	90	Wake	70
Craven	100	McDowell	70	Warren	70
Cumberland	80	Mecklenburg	70	Washington	100
Currituck	100	Mitchell	70	Watauga	70
Dare	110	Montgomery	70	Wayne	80
Davidson	70	Moore	70	Wilkes	70
Davie	70	Nash	80	Wilson	80
Duplin	90	New Hanover	100	Yadkin	70
Durham	70	Northampton	80	Yancey	70
Edgecombe	80	Onslow	100		
Forsyth	70	Orange	70		

B. Review and Approval

The Engineer is responsible for the review and approval of temporary works' drawings. Submit the working drawings sufficiently in advance of proposed use to allow for their review, revision (if needed), and approval without delay to the work.

The time period for review of the working drawings does not begin until complete drawings and design calculations, when required, are received by the Engineer.

Do not start construction of any temporary work for which working drawings are required until the drawings have been approved. Such approval does not relieve the Contractor of the responsibility for the accuracy and adequacy of the working drawings.

4.0 CONSTRUCTION REQUIREMENTS

All requirements of Section 420 of the Standard Specifications apply.

Construct temporary works in conformance with the approved working drawings. Ensure that the quality of materials and workmanship employed is consistent with that assumed in the design of the temporary works. Do not weld falsework members to any portion of the permanent structure unless approved. Show any welding to the permanent structure on the approved construction drawings.

Provide tell-tales attached to the forms and extending to the ground, or other means, for accurate measurement of falsework settlement. Make sure that the anticipated compressive settlement and/or deflection of falsework does not exceed 1 inch. For cast-in-place concrete structures, make sure that the calculated deflection of falsework flexural members does not exceed 1/240 of their span regardless of whether or not the deflection is compensated by camber strips.

A. Maintenance and Inspection

Inspect and maintain the temporary work in an acceptable condition throughout the period of its use. Certify that the manufactured devices have been maintained in a condition to allow them to safely carry their rated loads. Clearly mark each piece so that its capacity can be readily determined at the job site.

Perform an in-depth inspection of an applicable portion(s) of the temporary works, in the presence of the Engineer, not more than 24 hours prior to the beginning of each concrete placement. Inspect other temporary works at least once a month to ensure that they are functioning properly. Have a North Carolina Registered Professional Engineer inspect the cofferdams, shoring, sheathing, support of excavation structures, and support systems for load tests prior to loading.

B. Foundations

Determine the safe bearing capacity of the foundation material on which the supports for temporary works rest. If required by the Engineer, conduct load tests to verify proposed bearing capacity values that are marginal or in other high-risk situations.

The use of the foundation support values shown on the contract plans of the permanent structure is permitted if the foundations are on the same level and on the same soil as those of the permanent structure.

Allow for adequate site drainage or soil protection to prevent soil saturation and washout of the soil supporting the temporary works supports.

If piles are used, the estimation of capacities and later confirmation during construction using standard procedures based on the driving characteristics of the pile is permitted.

If preferred, use load tests to confirm the estimated capacities; or, if required by the Engineer conduct load tests to verify bearing capacity values that are marginal or in other high risk situations.

The Engineer reviews and approves the proposed pile and soil bearing capacities.

5.0 REMOVAL

Unless otherwise permitted, remove and keep all temporary works upon completion of the work. Do not disturb or otherwise damage the finished work.

Remove temporary works in conformance with the contract documents. Remove them in such a manner as to permit the structure to uniformly and gradually take the stresses due to its own weight.

6.0 METHOD OF MEASUREMENT

Unless otherwise specified, temporary works will not be directly measured.

7.0 BASIS OF PAYMENT

Payment at the contract unit prices for the various pay items requiring temporary works will be full compensation for the above falsework and formwork.

R-5734A

ST-9

Macon County

CRANE SAFETY**(8-15-05)**

Comply with the manufacturer specifications and limitations applicable to the operation of any and all cranes and derricks. Prime contractors, sub-contractors, and fully operated rental companies shall comply with the current Occupational Safety and Health Administration regulations (OSHA).

Submit all items listed below to the Engineer prior to beginning crane operations involving critical lifts. A critical lift is defined as any lift that exceeds 75 percent of the manufacturer's crane chart capacity for the radius at which the load will be lifted or requires the use of more than one crane. Changes in personnel or equipment must be reported to the Engineer and all applicable items listed below must be updated and submitted prior to continuing with crane operations.

CRANE SAFETY SUBMITTAL LIST

Competent Person: Provide the name and qualifications of the "Competent Person" responsible for crane safety and lifting operations. The named competent person will have the responsibility and authority to stop any work activity due to safety concerns.

Riggers: Provide the qualifications and experience of the persons responsible for rigging operations. Qualifications and experience should include, but not be limited to, weight calculations, center of gravity determinations, selection and inspection of sling and rigging equipment, and safe rigging practices.

Crane Inspections: Inspection records for all cranes shall be current and readily accessible for review upon request.

Certifications: By July 1, 2006, crane operators performing critical lifts shall be certified by NC CCO (National Commission for the Certification of Crane Operators), or satisfactorily complete the Carolinas AGC's Professional Crane Operator's Proficiency Program. Other approved nationally accredited programs will be considered upon request. All crane operators shall also have a current CDL medical card. Submit a list of anticipated critical lifts and corresponding crane operator(s). Include current certification for the type of crane operated (small hydraulic, large hydraulic, small lattice, large lattice) and medical evaluations for each operator.

R-5734A

ST-10

Macon County

GROUT FOR STRUCTURES**(12-1-17)****1.0 DESCRIPTION**

This special provision addresses grout for use in pile blockouts, grout pockets, shear keys, dowel holes and recesses for structures. This provision does not apply to grout placed in post-tensioning ducts for bridge beams, girders, decks, end bent caps, or bent caps. Mix and place grout in accordance with the manufacturer's recommendations, the applicable sections of the Standard Specifications and this provision.

2.0 MATERIAL REQUIREMENTS

Unless otherwise noted on the plans, use a Type 3 Grout in accordance with Section 1003 of the Standard Specifications.

Initial setting time shall not be less than 10 minutes when tested in accordance with ASTM C266.

Construction loading and traffic loading shall not be allowed until the 3 day compressive strength is achieved.

3.0 SAMPLING AND PLACEMENT

Place and maintain components in final position until grout placement is complete and accepted. Concrete surfaces to receive grout shall be free of defective concrete, laitance, oil, grease and other foreign matter. Saturate concrete surfaces with clean water and remove excess water prior to placing grout.

4.0 BASIS OF PAYMENT

No separate payment will be made for "Grout for Structures". The cost of the material, equipment, labor, placement, and any incidentals necessary to complete the work shall be considered incidental to the structure item requiring grout.

R-5734A

ST-11

Macon County

SUBMITTAL OF WORKING DRAWINGS**(6-28-17)****1.GENERAL**

Submit working drawings in accordance with Article 105-2 of the *Standard Specifications* and this provision. For this provision, “submittals” refers to only those listed in this provision. The list of submittals contained herein does not represent a list of required submittals for the project. Submittals are only necessary for those items as required by the contract. Make submittals that are not specifically noted in this provision directly to the Engineer. Either the Structures Management Unit or the Geotechnical Engineering Unit or both units will jointly review submittals.

If a submittal contains variations from plan details or specifications or significantly affects project cost, field construction or operations, discuss the submittal with and submit all copies to the Engineer. State the reason for the proposed variation in the submittal. To minimize review time, make sure all submittals are complete when initially submitted. Provide a contact name and information with each submittal. Direct any questions regarding submittal requirements to the Engineer, Structures Management Unit contacts or the Geotechnical Engineering Unit contacts noted below.

In order to facilitate in-plant inspection by NCDOT and approval of working drawings, provide the name, address and telephone number of the facility where fabrication will actually be done if different than shown on the title block of the submitted working drawings. This includes, but is not limited to, precast concrete items, prestressed concrete items and fabricated steel or aluminum items.

2.ADDRESSES AND CONTACTS

For submittals to the Structures Management Unit, use the following addresses:

Via US mail:

Mr. B. C. Hanks, P. E.
State Structures Engineer
North Carolina Department
of Transportation
Structures Management Unit
1581 Mail Service Center
Raleigh, NC 27699-1581

Attention: Mr. J. L. Bolden, P. E.

Via other delivery service:

Mr. B. C. Hanks, P. E.
State Structures Engineer
North Carolina Department
of Transportation
Structures Management Unit
1000 Birch Ridge Drive
Raleigh, NC 27610

Attention: Mr. J. L. Bolden, P. E.

Submittals may also be made via email.

Send submittals to:

jlbolden@ncdot.gov (James Bolden)

Send an additional e-copy of the submittal to the following address:

eomile@ncdot.gov (Emmanuel Omile)

R-5734A

ST-12

Macon County

mrorie@ncdot.gov (Madonna Rorie)

For submittals to the Geotechnical Engineering Unit, use the following addresses:

For projects in Divisions 1-7, use the following Eastern Regional Office address:

Via US mail:

Mr. Chris Kreider, P. E.
Eastern Regional Geotechnical
Manager
North Carolina Department
of Transportation
Geotechnical Engineering Unit
Eastern Regional Office
1570 Mail Service Center
Raleigh, NC 27699-1570

Via other delivery service:

Mr. Chris Kreider, P. E.
Eastern Regional Geotechnical
Manager
North Carolina Department
of Transportation
Geotechnical Engineering Unit
Eastern Regional Office
3301 Jones Sausage Road, Suite 100
Garner, NC 27529

Via Email: EastGeotechnicalSubmittal@ncdot.gov

For projects in Divisions 8-14, use the following Western Regional Office address:

Via US mail or other delivery service:

Mr. Eric Williams, P. E.
Western Regional Geotechnical
Manager
North Carolina Department
of Transportation
Geotechnical Engineering Unit
Western Regional Office
5253 Z Max Boulevard
Harrisburg, NC 28075

Via Email: WestGeotechnicalSubmittal@ncdot.gov

The status of the review of structure-related submittals sent to the Structures Management Unit can be viewed from the Unit’s website, via the “Drawing Submittal Status” link.

The status of the review of geotechnical-related submittals sent to the Geotechnical Engineering Unit can be viewed from the Unit’s website, via the “Geotechnical Construction Submittals” link.

Direct any questions concerning submittal review status, review comments or drawing markups to the following contacts:

Primary Structures Contact:

James Bolden
(919) 707 – 6408
(919)250–4082 facsimile
jlbolden@ncdot.gov

R-5734A

ST-13

Macon County

Secondary Structures Contacts: Emmanuel Omile (919) 707 – 6451
Madonna Rorie (919) 707 – 6508

Eastern Regional Geotechnical Contact (Divisions 1-7):
Chris Kreider (919) 662 – 4710
ckreider@ncdot.gov

Western Regional Geotechnical Contact (Divisions 8-14):
Eric Williams (704) 455 – 8902
ewilliams3@ncdot.gov

3. SUBMITTAL COPIES

Furnish one complete copy of each submittal, including all attachments, to the Engineer. At the same time, submit the number of hard copies shown below of the same complete submittal directly to the Structures Management Unit and/or the Geotechnical Engineering Unit.

The first table below covers “Structure Submittals”. The Engineer will receive review comments and drawing markups for these submittals from the Structures Management Unit. The second table in this section covers “Geotechnical Submittals”. The Engineer will receive review comments and drawing markups for these submittals from the Geotechnical Engineering Unit.

Unless otherwise required, submit one set of supporting calculations to either the Structures Management Unit or the Geotechnical Engineering Unit unless both units require submittal copies in which case submit a set of supporting calculations to each unit. Provide additional copies of any submittal as directed.

STRUCTURE SUBMITTALS

Submittal	Copies Required by Structures Management Unit	Copies Required by Geotechnical Engineering Unit	Contract Reference Requiring Submittal ¹
Arch Culvert Falsework	5	0	Plan Note, SN Sheet & “Falsework and Formwork”
Box Culvert Falsework ⁷	5	0	Plan Note, SN Sheet & “Falsework and Formwork”
Cofferdams	6	2	Article 410-4
Foam Joint Seals ⁶	9	0	“Foam Joint Seals”

R-5734A

ST-14

Macon County

Expansion Joint Seals (hold down plate type with base angle)	9	0	“Expansion Joint Seals”
Expansion Joint Seals (modular)	2, then 9	0	“Modular Expansion Joint Seals”
Expansion Joint Seals (strip seals)	9	0	“Strip Seals”
Falsework & Forms ² (substructure)	8	0	Article 420-3 & “Falsework and Formwork”
Falsework & Forms (superstructure)	8	0	Article 420-3 & “Falsework and Formwork”
Girder Erection over Railroad	5	0	Railroad Provisions
Maintenance and Protection of Traffic Beneath Proposed Structure	8	0	“Maintenance and Protection of Traffic Beneath Proposed Structure at Station ____”
Metal Bridge Railing	8	0	Plan Note
Metal Stay-in-Place Forms	8	0	Article 420-3
Metalwork for Elastomeric Bearings ^{4,5}	7	0	Article 1072-8
Miscellaneous Metalwork ^{4,5}	7	0	Article 1072-8
Disc Bearings ⁴	8	0	“Disc Bearings”
Overhead and Digital Message Signs (DMS) (metalwork and foundations)	13	0	Applicable Provisions
Placement of Equipment on Structures (cranes, etc.)	7	0	Article 420-20
Precast Concrete Box Culverts	2, then 1 reproducible	0	“Optional Precast Reinforced Concrete Box Culvert at Station ____”
Prestressed Concrete Cored Slab (detensioning sequences) ³	6	0	Article 1078-11
Prestressed Concrete Deck Panels	6 and	0	Article 420-3

R-5734A

ST-15

Macon County

	1 reproducible		
Prestressed Concrete Girder (strand elongation and detensioning sequences)	6	0	Articles 1078-8 and 1078- 11
Removal of Existing Structure over Railroad	5	0	Railroad Provisions
Revised Bridge Deck Plans (adaptation to prestressed deck panels)	2, then 1 reproducible	0	Article 420-3
Revised Bridge Deck Plans (adaptation to modular expansion joint seals)	2, then 1 reproducible	0	“Modular Expansion Joint Seals”
Sound Barrier Wall (precast items)	10	0	Article 1077-2 & “Sound Barrier Wall”
Sound Barrier Wall Steel Fabrication Plans ⁵	7	0	Article 1072-8 & “Sound Barrier Wall”
Structural Steel ⁴	2, then 7	0	Article 1072-8
Temporary Detour Structures	10	2	Article 400-3 & “Construction, Maintenance and Removal of Temporary Structure at Station _____”
TFE Expansion Bearings ⁴	8	0	Article 1072-8

FOOTNOTES

1. References are provided to help locate the part of the contract where the submittals are required. References in quotes refer to the provision by that name. Articles refer to the *Standard Specifications*.
2. Submittals for these items are necessary only when required by a note on plans.
3. Submittals for these items may not be required. A list of pre-approved sequences is available from the producer or the Materials & Tests Unit.
4. The fabricator may submit these items directly to the Structures Management Unit.
5. The two sets of preliminary submittals required by Article 1072-8 of the *Standard Specifications* are not required for these items.
6. Submittals for Fabrication Drawings are not required. Submittals for Catalogue Cuts of Proposed Material are required. See Section 5.A of the referenced provision.
7. Submittals are necessary only when the top slab thickness is 18” or greater.

R-5734A

ST-16

Macon County

GEOTECHNICAL SUBMITTALS

Submittal	Copies Required by Geotechnical Engineering Unit	Copies Required by Structures Management Unit	Contract Reference Requiring Submittal ¹
Drilled Pier Construction Plans ²	1	0	Subarticle 411-3(A)
Crosshole Sonic Logging (CSL) Reports ²	1	0	Subarticle 411-5(A)(2)
Pile Driving Equipment Data Forms ^{2,3}	1	0	Subarticle 450-3(D)(2)
Pile Driving Analyzer (PDA) Reports ²	1	0	Subarticle 450-3(F)(3)
Retaining Walls ⁴	1 drawings, 1 calculations	2 drawings	Applicable Provisions
Temporary Shoring ⁴	1 drawings, 1 calculations	2 drawings	“Temporary Shoring” & “Temporary Soil Nail Walls”

FOOTNOTES

- References are provided to help locate the part of the contract where the submittals are required. References in quotes refer to the provision by that name. Subarticles refer to the *Standard Specifications*.
- Submit one hard copy of submittal to the Engineer. Submit a second copy of submittal electronically (PDF via email), US mail or other delivery service to the appropriate Geotechnical Engineering Unit regional office. Electronic submission is preferred.
- The Pile Driving Equipment Data Form is available from:
https://connect.ncdot.gov/resources/Geological/Pages/Geotech_Forms_Details.aspx
See second page of form for submittal instructions.
- Electronic copy of submittal is required. See referenced provision.

17BP.14.R154

ST-17

Macon County

PROJECT SPECIAL PROVISIONS**STRUCTURES:**

Prepared by:
 STV Engineers, Inc.
 900 West Trade Street, Suite 715
 Charlotte, NC 28202
 704/372-1885
 NC License Number F-0991

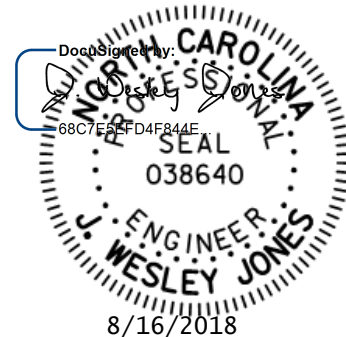

Document not considered Final
 Unless All Signatures Completed

FALSEWORK AND FORMWORK**(4-5-12)****1.0 DESCRIPTION**

Use this Special Provision as a guide to develop temporary works submittals required by the Standard Specifications or other provisions; no additional submittals are required herein. Such temporary works include, but are not limited to, falsework and formwork.

Falsework is any temporary construction used to support the permanent structure until it becomes self-supporting. Formwork is the temporary structure or mold used to retain plastic or fluid concrete in its designated shape until it hardens. Access scaffolding is a temporary structure that functions as a work platform that supports construction personnel, materials, and tools, but is not intended to support the structure. Scaffolding systems that are used to temporarily support permanent structures (as opposed to functioning as work platforms) are considered to be falsework under the definitions given. Shoring is a component of falsework such as horizontal, vertical, or inclined support members. Where the term “temporary works” is used, it includes all of the temporary facilities used in bridge construction that do not become part of the permanent structure.

Design and construct safe and adequate temporary works that will support all loads imposed and provide the necessary rigidity to achieve the lines and grades shown on the plans in the final structure.

2.0 MATERIALS

Select materials suitable for temporary works; however, select materials that also ensure the safety and quality required by the design assumptions. The Engineer has authority to reject material on the basis of its condition, inappropriate use, safety, or nonconformance with the plans. Clearly identify allowable loads or stresses for all materials or manufactured devices on the plans. Revise the plan and notify the Engineer if any change to materials or material strengths is required.

3.0 DESIGN REQUIREMENTS**A. Working Drawings**

Provide working drawings for items as specified in the contract, or as required by the Engineer, with design calculations and supporting data in sufficient detail to permit a structural and safety review of the proposed design of the temporary work.

On the drawings, show all information necessary to allow the design of any component to be checked independently as determined by the Engineer.

When concrete placement is involved, include data such as the drawings of proposed sequence, rate of placement, direction of placement, and location of all construction joints. Submit the number of copies as called for by the contract.

When required, have the drawings and calculations prepared under the guidance of, and sealed by, a North Carolina Registered Professional Engineer who is knowledgeable in temporary works design.

If requested by the Engineer, submit with the working drawings manufacturer's catalog data listing the weight of all construction equipment that will be supported on the temporary work. Show anticipated total settlements and/or deflections of falsework and forms on the working drawings. Include falsework footing settlements, joint take-up, and deflection of beams or girders.

As an option for the Contractor, overhang falsework hangers may be uniformly spaced, at a maximum of 36 inches, provided the following conditions are met:

Member Type (PCG)	Member Depth, (inches)	Max. Overhang Width, (inches)	Max. Slab Edge Thickness, (inches)	Max. Screenshot Wheel Weight, (lbs.)	Bracket Min. Vertical Leg Extension, (inches)
II	36	39	14	2000	26
III	45	42	14	2000	35
IV	54	45	14	2000	44
MBT	63	51	12	2000	50
MBT	72	55	12	1700	48

Overhang width is measured from the centerline of the girder to the edge of the deck slab.

For Type II, III & IV prestressed concrete girders (PCG), 45-degree cast-in-place half hangers and rods must have a minimum safe working load of 6,000 lbs.

For MBT prestressed concrete girders, 45-degree angle holes for falsework hanger rods shall be cast through the girder top flange and located, measuring along the top of the member, 1'-2 1/2" from the edge of the top flange. Hanger hardware and rods must have a minimum safe working load of 6,000 lbs.

The overhang bracket provided for the diagonal leg shall have a minimum safe working load of 3,750 lbs. The vertical leg of the bracket shall extend to the point that the heel bears on the girder bottom flange, no closer than 4 inches from the bottom of the member.

However, for 72-inch members, the heel of the bracket shall bear on the web, near the bottom flange transition.

Provide adequate overhang falsework and determine the appropriate adjustments for deck geometry, equipment, casting procedures and casting conditions.

If the optional overhang falsework spacing is used, indicate this on the falsework submittal and advise the girder producer of the proposed details. Failure to notify the Engineer of hanger type and hanger spacing on prestressed concrete girder casting drawings may delay the approval of those drawings.

Falsework hangers that support concentrated loads and are installed at the edge of thin top flange concrete girders (such as bulb tee girders) shall be spaced so as not to exceed 75% of the manufacturer's stated safe working load. Use of dual leg hangers (such as Meadow Burke HF-42 and HF-43) are not allowed on concrete girders with thin top flanges. Design the falsework and forms supporting deck slabs and overhangs on girder bridges so that there will be no differential settlement between the girders and the deck forms during placement of deck concrete.

When staged construction of the bridge deck is required, detail falsework and forms for screed and fluid concrete loads to be independent of any previous deck pour components when the mid-span girder deflection due to deck weight is greater than $\frac{3}{4}$ ".

Note on the working drawings any anchorages, connectors, inserts, steel sleeves or other such devices used as part of the falsework or formwork that remains in the permanent structure. If the plan notes indicate that the structure contains the necessary corrosion protection required for a Corrosive Site, epoxy coat, galvanize or metalize these devices. Electroplating will not be allowed. Any coating required by the Engineer will be considered incidental to the various pay items requiring temporary works.

Design falsework and formwork requiring submittals in accordance with the 1995 AASHTO *Guide Design Specifications for Bridge Temporary Works* except as noted herein.

1. Wind Loads

Table 2.2 of Article 2.2.5.1 is modified to include wind velocities up to 110 mph. In addition, Table 2.2A is included to provide the maximum wind speeds by county in North Carolina.

Table 2.2 - Wind Pressure Values

Height Zone feet above ground	Pressure, lb/ft ² for Indicated Wind Velocity, mph				
	70	80	90	100	110
0 to 30	15	20	25	30	35
30 to 50	20	25	30	35	40
50 to 100	25	30	35	40	45
over 100	30	35	40	45	50

2. Time of Removal

The following requirements replace those of Article 3.4.8.2.

Do not remove forms until the concrete has attained strengths required in Article 420-16 of the Standard Specifications and these Special Provisions.

Do not remove forms until the concrete has sufficient strength to prevent damage to the surface.

Table 2.2A - Steady State Maximum Wind Speeds by Counties in North Carolina

COUNTY	25 YR (mph)	COUNTY	25 YR (mph)	COUNTY	25 YR (mph)
Alamance	70	Franklin	70	Pamlico	100
Alexander	70	Gaston	70	Pasquotank	100
Alleghany	70	Gates	90	Pender	100
Anson	70	Graham	80	Perquimans	100
Ashe	70	Granville	70	Person	70
Avery	70	Greene	80	Pitt	90
Beaufort	100	Guilford	70	Polk	80
Bertie	90	Halifax	80	Randolph	70
Bladen	90	Harnett	70	Richmond	70
Brunswick	100	Haywood	80	Robeson	80
Buncombe	80	Henderson	80	Rockingham	70
Burke	70	Hertford	90	Rowan	70
Cabarrus	70	Hoke	70	Rutherford	70
Caldwell	70	Hyde	110	Sampson	90
Camden	100	Iredell	70	Scotland	70
Carteret	110	Jackson	80	Stanley	70
Caswell	70	Johnston	80	Stokes	70
Catawba	70	Jones	100	Surry	70
Cherokee	80	Lee	70	Swain	80
Chatham	70	Lenoir	90	Transylvania	80
Chowan	90	Lincoln	70	Tyrell	100
Clay	80	Macon	80	Union	70
Cleveland	70	Madison	80	Vance	70
Columbus	90	Martin	90	Wake	70
Craven	100	McDowell	70	Warren	70
Cumberland	80	Mecklenburg	70	Washington	100
Currituck	100	Mitchell	70	Watauga	70
Dare	110	Montgomery	70	Wayne	80
Davidson	70	Moore	70	Wilkes	70
Davie	70	Nash	80	Wilson	80
Duplin	90	New Hanover	100	Yadkin	70
Durham	70	Northampton	80	Yancey	70
Edgecombe	80	Onslow	100		
Forsyth	70	Orange	70		

B. Review and Approval

The Engineer is responsible for the review and approval of temporary works' drawings. Submit the working drawings sufficiently in advance of proposed use to allow for their review, revision (if needed), and approval without delay to the work.

The time period for review of the working drawings does not begin until complete drawings and design calculations, when required, are received by the Engineer.

Do not start construction of any temporary work for which working drawings are required until the drawings have been approved. Such approval does not relieve the Contractor of the responsibility for the accuracy and adequacy of the working drawings.

4.0 CONSTRUCTION REQUIREMENTS

All requirements of Section 420 of the Standard Specifications apply.

Construct temporary works in conformance with the approved working drawings. Ensure that the quality of materials and workmanship employed is consistent with that assumed in the design of the temporary works. Do not weld falsework members to any portion of the permanent structure unless approved. Show any welding to the permanent structure on the approved construction drawings.

Provide tell-tales attached to the forms and extending to the ground, or other means, for accurate measurement of falsework settlement. Make sure that the anticipated compressive settlement and/or deflection of falsework does not exceed 1 inch. For cast-in-place concrete structures, make sure that the calculated deflection of falsework flexural members does not exceed 1/240 of their span regardless of whether or not the deflection is compensated by camber strips.

A. Maintenance and Inspection

Inspect and maintain the temporary work in an acceptable condition throughout the period of its use. Certify that the manufactured devices have been maintained in a condition to allow them to safely carry their rated loads. Clearly mark each piece so that its capacity can be readily determined at the job site.

Perform an in-depth inspection of an applicable portion(s) of the temporary works, in the presence of the Engineer, not more than 24 hours prior to the beginning of each concrete placement. Inspect other temporary works at least once a month to ensure that they are functioning properly. Have a North Carolina Registered Professional Engineer inspect the cofferdams, shoring, sheathing, support of excavation structures, and support systems for load tests prior to loading.

B. Foundations

Determine the safe bearing capacity of the foundation material on which the supports for temporary works rest. If required by the Engineer, conduct load tests to verify proposed bearing capacity values that are marginal or in other high-risk situations.

The use of the foundation support values shown on the contract plans of the permanent structure is permitted if the foundations are on the same level and on the same soil as those of the permanent structure.

Allow for adequate site drainage or soil protection to prevent soil saturation and washout of the soil supporting the temporary works supports.

If piles are used, the estimation of capacities and later confirmation during construction using standard procedures based on the driving characteristics of the pile is permitted. If preferred, use load tests to confirm the estimated capacities; or, if required by the Engineer conduct load tests to verify bearing capacity values that are marginal or in other high risk situations.

The Engineer reviews and approves the proposed pile and soil bearing capacities.

5.0 REMOVAL

Unless otherwise permitted, remove and keep all temporary works upon completion of the work. Do not disturb or otherwise damage the finished work.

Remove temporary works in conformance with the contract documents. Remove them in such a manner as to permit the structure to uniformly and gradually take the stresses due to its own weight.

6.0 METHOD OF MEASUREMENT

Unless otherwise specified, temporary works will not be directly measured.

7.0 BASIS OF PAYMENT

Payment at the contract unit prices for the various pay items requiring temporary works will be full compensation for the above falsework and formwork.

SUBMITTAL OF WORKING DRAWINGS**(6-28-17)****1.0 GENERAL**

Submit working drawings in accordance with Article 105-2 of the *Standard Specifications* and this provision. For this provision, "submittals" refers to only those listed in this provision. The list of submittals contained herein does not represent a list of required submittals for the project. Submittals are only necessary for those items as required by the contract. Make submittals that are not specifically noted in this provision directly to the

17BP.14.R154

ST-24

Macon County

Engineer. Either the Structures Management Unit or the Geotechnical Engineering Unit or both units will jointly review submittals.

If a submittal contains variations from plan details or specifications or significantly affects project cost, field construction or operations, discuss the submittal with and submit all copies to the Engineer. State the reason for the proposed variation in the submittal. To minimize review time, make sure all submittals are complete when initially submitted. Provide a contact name and information with each submittal. Direct any questions regarding submittal requirements to the Engineer, Structures Management Unit contacts or the Geotechnical Engineering Unit contacts noted below.

In order to facilitate in-plant inspection by NCDOT and approval of working drawings, provide the name, address and telephone number of the facility where fabrication will actually be done if different than shown on the title block of the submitted working drawings. This includes, but is not limited to, precast concrete items, prestressed concrete items and fabricated steel or aluminum items.

2.0 ADDRESSES AND CONTACTS

For submittals to the Structures Management Unit, use the following addresses:

Via US mail:

Mr. B. C. Hanks, P. E.
State Structures Engineer
North Carolina Department
of Transportation
Structures Management Unit
1581 Mail Service Center
Raleigh, NC 27699-1581

Attention: Mr. J. L. Bolden, P. E.

Via other delivery service:

Mr. B. C. Hanks, P. E.
State Structures Engineer
North Carolina Department
of Transportation
Structures Management Unit
1000 Birch Ridge Drive
Raleigh, NC 27610

Attention: Mr. J. L. Bolden, P. E.

Submittals may also be made via email.

Send submittals to:

jlbolden@ncdot.gov (James Bolden)

Send an additional e-copy of the submittal to the following address:

eomile@ncdot.gov (Emmanuel Omile)

mrorie@ncdot.gov (Madonna Rorie)

For submittals to the Geotechnical Engineering Unit, use the following addresses:

For projects in Divisions 1-7, use the following Eastern Regional Office address:

Via US mail:

Mr. Chris Kreider, P. E.
Eastern Regional Geotechnical
Manager
North Carolina Department
of Transportation
Geotechnical Engineering Unit
Eastern Regional Office
1570 Mail Service Center
Raleigh, NC 27699-1570

Via other delivery service:

Mr. Chris Kreider, P. E.
Eastern Regional Geotechnical
Manager
North Carolina Department
of Transportation
Geotechnical Engineering Unit
Eastern Regional Office
3301 Jones Sausage Road, Suite 100
Garner, NC 27529

Via Email: EastGeotechnicalSubmittal@ncdot.gov

For projects in Divisions 8-14, use the following Western Regional Office address:

Via US mail or other delivery service:

Mr. Eric Williams, P. E.
Western Regional Geotechnical
Manager
North Carolina Department
of Transportation
Geotechnical Engineering Unit
Western Regional Office
5253 Z Max Boulevard
Harrisburg, NC 28075

Via Email: WestGeotechnicalSubmittal@ncdot.gov

The status of the review of structure-related submittals sent to the Structures Management Unit can be viewed from the Unit's website, via the "Drawing Submittal Status" link.

The status of the review of geotechnical-related submittals sent to the Geotechnical Engineering Unit can be viewed from the Unit's website, via the "Geotechnical Construction Submittals" link.

17BP.14.R154

ST-26

Macon County

Direct any questions concerning submittal review status, review comments or drawing markups to the following contacts:

Primary Structures Contact: James Bolden (919) 707 – 6408
(919) 250 – 4082 facsimile
jlbolden@ncdot.gov

Secondary Structures Contacts: Emmanuel Omile (919) 707 – 6451
Madonna Rorie (919) 707 – 6508

Eastern Regional Geotechnical Contact (Divisions 1-7):
Chris Kreider (919) 662 – 4710
ckreider@ncdot.gov

Western Regional Geotechnical Contact (Divisions 8-14):
Eric Williams (704) 455 – 8902
ewilliams3@ncdot.gov

3.0 SUBMITTAL COPIES

Furnish one complete copy of each submittal, including all attachments, to the Engineer. At the same time, submit the number of hard copies shown below of the same complete submittal directly to the Structures Management Unit and/or the Geotechnical Engineering Unit.

The first table below covers “Structure Submittals”. The Engineer will receive review comments and drawing markups for these submittals from the Structures Management Unit. The second table in this section covers “Geotechnical Submittals”. The Engineer will receive review comments and drawing markups for these submittals from the Geotechnical Engineering Unit.

Unless otherwise required, submit one set of supporting calculations to either the Structures Management Unit or the Geotechnical Engineering Unit unless both units require submittal copies in which case submit a set of supporting calculations to each unit. Provide additional copies of any submittal as directed.

17BP.14.R154

ST-27

Macon County

STRUCTURE SUBMITTALS

Submittal	Copies Required by Structures Management Unit	Copies Required by Geotechnical Engineering Unit	Contract Reference Requiring Submittal ¹
Arch Culvert Falsework	5	0	Plan Note, SN Sheet & “Falsework and Formwork”
Box Culvert Falsework ⁷	5	0	Plan Note, SN Sheet & “Falsework and Formwork”
Cofferdams	6	2	Article 410-4
Foam Joint Seals ⁶	9	0	“Foam Joint Seals”
Expansion Joint Seals (hold down plate type with base angle)	9	0	“Expansion Joint Seals”
Expansion Joint Seals (modular)	2, then 9	0	“Modular Expansion Joint Seals”
Expansion Joint Seals (strip seals)	9	0	“Strip Seals”
Falsework & Forms ² (substructure)	8	0	Article 420-3 & “Falsework and Formwork”
Falsework & Forms (superstructure)	8	0	Article 420-3 & “Falsework and Formwork”
Girder Erection over Railroad	5	0	Railroad Provisions
Maintenance and Protection of Traffic Beneath Proposed Structure	8	0	“Maintenance and Protection of Traffic Beneath Proposed Structure at Station ____”
Metal Bridge Railing	8	0	Plan Note
Metal Stay-in-Place Forms	8	0	Article 420-3
Metalwork for Elastomeric	7	0	Article 1072-8

17BP.14.R154

ST-28

Macon County

Bearings ^{4,5}

Miscellaneous Metalwork ^{4,5}	7	0	Article 1072-8
Disc Bearings ⁴	8	0	“Disc Bearings”
Overhead and Digital Message Signs (DMS) (metalwork and foundations)	13	0	Applicable Provisions
Placement of Equipment on Structures (cranes, etc.)	7	0	Article 420-20
Precast Concrete Box Culverts	2, then 1 reproducible	0	“Optional Precast Reinforced Concrete Box Culvert at Station ____”
Prestressed Concrete Cored Slab (detensioning sequences) ³	6	0	Article 1078-11
Prestressed Concrete Deck Panels	6 and 1 reproducible	0	Article 420-3
Prestressed Concrete Girder (strand elongation and detensioning sequences)	6	0	Articles 1078-8 and 1078-11
Removal of Existing Structure over Railroad	5	0	Railroad Provisions
Revised Bridge Deck Plans (adaptation to prestressed deck panels)	2, then 1 reproducible	0	Article 420-3
Revised Bridge Deck Plans (adaptation to modular expansion joint seals)	2, then 1 reproducible	0	“Modular Expansion Joint Seals”
Sound Barrier Wall (precast items)	10	0	Article 1077-2 & “Sound Barrier Wall”
Sound Barrier Wall Steel Fabrication Plans ⁵	7	0	Article 1072-8 & “Sound Barrier Wall”
Structural Steel ⁴	2, then 7	0	Article 1072-8

17BP.14.R154

ST-29

Macon County

Temporary Detour Structures	10	2	Article 400-3 & “Construction, Maintenance and Removal of Temporary Structure at Station _____”
TFE Expansion Bearings ⁴	8	0	Article 1072-8

FOOTNOTES

1. References are provided to help locate the part of the contract where the submittals are required. References in quotes refer to the provision by that name. Articles refer to the *Standard Specifications*.
2. Submittals for these items are necessary only when required by a note on plans.
3. Submittals for these items may not be required. A list of pre-approved sequences is available from the producer or the Materials & Tests Unit.
4. The fabricator may submit these items directly to the Structures Management Unit.
5. The two sets of preliminary submittals required by Article 1072-8 of the *Standard Specifications* are not required for these items.
6. Submittals for Fabrication Drawings are not required. Submittals for Catalogue Cuts of Proposed Material are required. See Section 5.A of the referenced provision.
7. Submittals are necessary only when the top slab thickness is 18” or greater.

17BP.14.R154

ST-30

Macon County

GEOTECHNICAL SUBMITTALS

Submittal	Copies Required by Geotechnical Engineering Unit	Copies Required by Structures Management Unit	Contract Reference Requiring Submittal ¹
Drilled Pier Construction Plans ²	1	0	Subarticle 411-3(A)
Crosshole Sonic Logging (CSL) Reports ²	1	0	Subarticle 411-5(A)(2)
Pile Driving Equipment Data Forms ^{2,3}	1	0	Subarticle 450-3(D)(2)
Pile Driving Analyzer (PDA) Reports ²	1	0	Subarticle 450-3(F)(3)
Retaining Walls ⁴	1 drawings, 1 calculations	2 drawings	Applicable Provisions
Temporary Shoring ⁴	1 drawings, 1 calculations	2 drawings	“Temporary Shoring” & “Temporary Soil Nail Walls”

FOOTNOTES

- References are provided to help locate the part of the contract where the submittals are required. References in quotes refer to the provision by that name. Subarticles refer to the *Standard Specifications*.
- Submit one hard copy of submittal to the Engineer. Submit a second copy of submittal electronically (PDF via email), US mail or other delivery service to the appropriate Geotechnical Engineering Unit regional office. Electronic submission is preferred.
- The Pile Driving Equipment Data Form is available from:
https://connect.ncdot.gov/resources/Geological/Pages/Geotech_Forms_Details.aspx
See second page of form for submittal instructions.

Electronic copy of submittal is required. See referenced provision.

17BP.14.R154

ST-31

Macon County

CRANE SAFETY**(8-15-05)**

Comply with the manufacturer specifications and limitations applicable to the operation of any and all cranes and derricks. Prime contractors, sub-contractors, and fully operated rental companies shall comply with the current Occupational Safety and Health Administration regulations (OSHA).

Submit all items listed below to the Engineer prior to beginning crane operations involving critical lifts. A critical lift is defined as any lift that exceeds 75 percent of the manufacturer's crane chart capacity for the radius at which the load will be lifted or requires the use of more than one crane. Changes in personnel or equipment must be reported to the Engineer and all applicable items listed below must be updated and submitted prior to continuing with crane operations.

CRANE SAFETY SUBMITTAL LIST

- A. **Competent Person:** Provide the name and qualifications of the "Competent Person" responsible for crane safety and lifting operations. The named competent person will have the responsibility and authority to stop any work activity due to safety concerns.
- B. **Riggers:** Provide the qualifications and experience of the persons responsible for rigging operations. Qualifications and experience should include, but not be limited to, weight calculations, center of gravity determinations, selection and inspection of sling and rigging equipment, and safe rigging practices.
- C. **Crane Inspections:** Inspection records for all cranes shall be current and readily accessible for review upon request.
- D. **Certifications:** **By July 1, 2006**, crane operators performing critical lifts shall be certified by NC CCO (National Commission for the Certification of Crane Operators), or satisfactorily complete the Carolinas AGC's Professional Crane Operator's Proficiency Program. Other approved nationally accredited programs will be considered upon request. All crane operators shall also have a current CDL medical card. Submit a list of anticipated critical lifts and corresponding crane operator(s). Include current certification for the type of crane operated (small hydraulic, large hydraulic, small lattice, large lattice) and medical evaluations for each operator.

GROUT FOR STRUCTURES**(12-1-17)****1.0 DESCRIPTION**

This special provision addresses grout for use in pile blockouts, grout pockets, shear keys, dowel holes and recesses for structures. This provision does not apply to grout placed in post-tensioning ducts for bridge beams, girders, decks, end bent caps, or bent caps. Mix and place grout in accordance with the manufacturer's recommendations, the applicable sections of the Standard Specifications and this provision.

17BP.14.R154

ST-32

Macon County

2.0 MATERIAL REQUIREMENTS

Unless otherwise noted on the plans, use a Type 3 Grout in accordance with Section 1003 of the Standard Specifications.

Initial setting time shall not be less than 10 minutes when tested in accordance with ASTM C266.

Construction loading and traffic loading shall not be allowed until the 3 day compressive strength is achieved.

3.0 SAMPLING AND PLACEMENT

Place and maintain components in final position until grout placement is complete and accepted. Concrete surfaces to receive grout shall be free of defective concrete, laitance, oil, grease and other foreign matter. Saturate concrete surfaces with clean water and remove excess water prior to placing grout.

4.0 BASIS OF PAYMENT

No separate payment will be made for "Grout for Structures". The cost of the material, equipment, labor, placement, and any incidentals necessary to complete the work shall be considered incidental to the structure item requiring grout.

ASBESTOS ASSESSMENT FOR BRIDGE DEMOLITION AND RENOVATION ACTIVITIES**(12-30-15)****INSPECTION FOR ASBESTOS CONTAINING MATERIAL**

Prior to conducting bridge demolition or renovation activities, the Contractor shall thoroughly inspect the bridge or affected components for the presence of asbestos containing material (ACM) using a firm prequalified by NCDOT to perform asbestos surveys. The inspection must be performed by a N.C. accredited asbestos inspector with experience inspecting bridges or other industrial structures. The N.C. accredited asbestos inspector must conduct a thorough inspection, identifying all asbestos-containing material as required by the Environmental Protection Agency National Emission Standards for Hazardous Air Pollutants (NESHAP) Code of Federal Regulations (CFR) 40 CFR, Part 61, Subpart M.

The Contractor shall submit an inspection report to the Engineer, which at a minimum must include information required in 40 CFR 763.85 (a)(4) vi)(A)-(E), as well as a project location map, photos of existing structure, the date of inspection and the name, N.C. accreditation number, and signature of the N.C. accredited asbestos inspector who performed the inspection and completed the report. The cover sheet of the report shall

17BP.14.R154

ST-33

Macon County

include project identification information. Place the following notes on the cover sheet of the report and check the appropriate box:

ACM was found

ACM was not found

REMOVAL AND DISPOSAL OF ASBESTOS CONTAINING MATERIAL

If ACM is found, notify the Engineer. Compensation for removal and disposal of ACM is considered extra work in accordance with Article 104-7 of the Standard Specifications.

An Asbestos Removal Permit must be obtained from the Health Hazards Control Unit (HHCU) of the N.C. Department of Health & Human Services, Division of Public Health, if more than 35 cubic feet, 160 square feet, or 260 linear feet of regulated ACM (RACM) is to be removed from a structure and this work must be completed by a contractor prequalified by NCDOT to perform asbestos abatement. RACM is defined in 40 CFR, Part 61, Subpart M. Note: 40 CFR 763.85 (a)(4) vi)(D) defines ACM as surfacing, TSI and Miscellaneous which does not meet the NESHAP RACM.

DEMOLITION NOTIFICATION

Even if no ACM is found (or if quantities are less than those required for a permit), a Demolition Notification (DHHS-3768) must be submitted to the HHCU. Notifications and Asbestos Permit applications require an original signature and must be submitted to the HHCU 10 working days prior to beginning demolition activities. The 10 working day period starts based on the post-marked date or date of hand delivery. Demolition that does not begin as originally notified requires submission of a separate revision form HHCU 3768-R to HHCU. Reference the North Carolina Administrative Code, Chapter 10A, Subchapter 41C, Article .0605 for directives on revision submissions.

Contact Information

Health Hazards Control Unit (HHCU)
N.C. Department of Health and Human Services
1912 Mail Service Center
Raleigh, NC 27699-1912
Telephone: (919) 707-5950
Fax: (919) 870-4808

17BP.14.R154

ST-34

Macon County

SPECIAL CONSIDERATIONS

Buncombe, Forsyth, and Mecklenburg counties also have asbestos permitting and NESHAP requirements must be followed. For projects involving permitted RACM removals, both the applicable county and the state (HHCU) must be notified.

For demolitions with no RACM, only the local environmental agencies must be notified. Contact information is as follows:

Buncombe County

WNC Regional Air Pollution Control Agency
49 Mt. Carmel Road
Asheville, NC 28806
(828) 250-6777

Forsyth County

Environmental Affairs Department
537 N. Spruce Street
Winston-Salem, NC 27101
(336) 703-2440

Mecklenburg County

Land Use and Environmental Services Agency
Mecklenburg Air Quality
700 N. Tryon Street
Charlotte, NC 28202
(704) 336-5430

ADDITIONAL INFORMATION

Additional information may be found on N.C. asbestos rules, regulations, procedures and N.C. accredited inspectors, as well as associated forms for demolition notifications and asbestos permit applications at the N.C. Asbestos Hazard Management Program website:

www.epi.state.nc.us/epi/asbestos/ahmp.html

BASIS OF PAYMENT

Payment for the work required in this provision will be at the lump sum contract unit price for "Asbestos Assessment". Such payment will be full compensation for all asbestos inspections, reports, permitting and notifications.

17BP.14.R154

ST-35

Macon County

**CONSTRUCTION, MAINTENANCE AND REMOVAL
OF TEMPORARY ACCESS AT STATION 14+94.00 -L-****(12-12-13)****1.0 GENERAL**

Construct, maintain, and remove the temporary access required to provide the working area necessary for construction of the new bridge, construction of the temporary detour structure, or for the removal of an existing bridge, as applicable. Temporary access may involve the use of a rock causeway [workpad], a work bridge, or other methods; however, all types of temporary access are required to meet the requirements of all permits, the Standard Specifications, and this Special Provision.

2.0 TEMPORARY ROCK CAUSEWAY [WORKPAD]

At the contractor's option, construction of a temporary rock causeway [workpad] within the limits shown on the plans is permitted. Build the causeway [workpad] with Class II riprap topped by a layer of Class B riprap or as otherwise designated on the plans or approved by the Engineer. If desired, recycle the Class II riprap used in the causeway [workpad] for placement in the final riprap slope protection as directed by the Engineer. No payment will be made for recycled riprap as this material is considered incidental to the causeway [workpad] placement and removal. If this option is exercised, no adjustment in contract bid price will be allowed due to an underrun in the quantity of "Rip Rap Class II (2'-0" Thick)".

Completely remove all causeway [workpad] material including pipes and return the entire causeway [workpad] footprint to the original contours and elevations within 90 days of the completion of the deck slab or as otherwise required by permits.

For sites affected by moratoriums or restrictions on in-stream work: Do not construct or remove causeway [workpad] during the moratorium period shown on the permit. If the completion of the deck slab falls within the prohibitive dates for causeway [workpad] construction or removal, begin causeway [workpad] removal immediately following the prohibitive dates.

3.0 TEMPORARY WORK BRIDGE

At the contractor's option, construction of a temporary work bridge in lieu of the causeway(s) [workpad] is acceptable, provided the temporary work bridge satisfies all permits. Submit details of the temporary work bridge to the Engineer prior to constructing the work bridge to ensure conformance with the plans and all permits. Completely remove the temporary bridge prior to final acceptance or as otherwise required by the permits.

17BP.14.R154

ST-36

Macon County

4.0 BASIS OF PAYMENT

The lump sum price bid for “Construction, Maintenance and Removal of Temporary Access at Station 14+94.00 -L-” will be full compensation for the above work, or other methods of access, including all material, pipes, work bridge components, equipment, tools, labor, disposal, and incidentals necessary to complete the work.

PROJECT SPECIAL PROVISION

(10-18-95) (Rev. 3-21-17)

Z-1

PERMITS

The Contractor's attention is directed to the following permits, which have been issued to the Department of Transportation by the authority granting the permit.

<u>PERMIT</u>	<u>AUTHORITY GRANTING THE PERMIT</u>
Dredge and Fill and/or Work in Navigable Waters (404)	U. S. Army Corps of Engineers
Water Quality (401)	Division of Environmental Management, DEQ State of North Carolina

The Contractor shall comply with all applicable permit conditions during construction of this project. Those conditions marked by * are the responsibility of the Department and the Contractor has no responsibility in accomplishing those conditions.

Agents of the permitting authority will periodically inspect the project for adherence to the permits.

The Contractor's attention is also directed to Articles 107-10 and 107-13 of the *2018 Standard Specifications* and the following:

Should the Contractor propose to utilize construction methods (such as temporary structures or fill in waters and/or wetlands for haul roads, work platforms, cofferdams, etc.) not specifically identified in the permit (individual, general, or nationwide) authorizing the project it shall be the Contractor's responsibility to coordinate with the Engineer to determine what, if any, additional permit action is required. The Contractor shall also be responsible for initiating the request for the authorization of such construction method by the permitting agency. The request shall be submitted through the Engineer. The Contractor shall not utilize the construction method until it is approved by the permitting agency. The request normally takes approximately 60 days to process; however, no extensions of time or additional compensation will be granted for delays resulting from the Contractor's request for approval of construction methods not specifically identified in the permit.

Where construction moratoriums are contained in a permit condition which restricts the Contractor's activities to certain times of the year, those moratoriums will apply only to the portions of the work taking place in the restricted waters, wetlands or buffer zones, provided that activities outside those areas is done in such a manner as to not affect the restricted waters, wetlands or buffer zones.

DocuSigned by:

 68A7405FFA5F48E...

Adams, Frederick C

From: McHenry, David G
Sent: Monday, August 6, 2018 1:36 PM
To: Kennedy, Durwood R
Cc: Breedlove, Patrick J; Mcdowell, Kenneth J; Adams, Frederick C
Subject: RE: R-5734A / 17BP.14.R.154 Macon Co.
Attachments: FW: [External] NWP verification for SAW-2017-02437, Bridge 314 on SR 1152, Macon County

Yes, the Wildlife Resources asked for a long moratorium for the R-5734 A project (permit pending). Attached is all the permit information for the bridge project; bridge project managers never put on sharepoint.

Please include the information as instructed in the email. Note however that for some reason there was no moratorium specified in the 314 404 permit, though it stands to reason we should follow it here. So, in the moratoriums section of the contract, there needs to be a long moratorium for trout as well as the April 15 to October 15 no tree clearing allowed restriction for Indiana bats.

I have done all I can to get the 404 permit as well as the trout buffer zone variance for the R-5734A project – they should be here any day.

Please advise if you have any questions.

Thanks

Dave

From: Kennedy, Durwood R
Sent: Monday, August 6, 2018 1:03 PM
To: McHenry, David G <dgmchenry@ncdot.gov>
Cc: Breedlove, Patrick J <pjbreedlove@ncdot.gov>; Mcdowell, Kenneth J <kjmcowell@ncdot.gov>; Adams, Frederick C <fadams@ncdot.gov>
Subject: R-5734A / 17BP.14.R.154 Macon Co.

David,
For the R-5734A in Macon County, it appears the 401 Permit requires a Trout Moratorium be observed from October 15th thru April 15th each year.

Now that R-5734A has been combined with the 17BP.14.R.154 bridge replacement project, will the same moratorium apply to it as well? Are additional permits required/pending for the 17BP.14.R.154 section of this project?

Sincerely,

Ken Kennedy, PE
Contract Time Engineer
Contract Standards and Development
North Carolina Department of Transportation

919 707 6919 office
drkennedy1@ncdot.gov

Adams, Frederick C

From: McHenry, David G
Sent: Wednesday, January 3, 2018 8:16 AM
To: Deyton, Joshua B; McCray, John R
Cc: Breedlove, Patrick J
Subject: FW: [External] NWP verification for SAW-2017-02437, Bridge 314 on SR 1152, Macon County
Attachments: 2017NWP33.pdf; [EXTERNAL] RE: [External] USACE questions re PCN for Bridge 314 in Macon Co.; GC4141.pdf

Here's the permits for Macon 314.

We need to include in the contract:

- (1) this email since it constitutes the authorization to use NWP 33
- (2) the attached NWP 33
- (3) the attached GC 4141 (which is the "automatic" WQ certification that matched the NWP 33)

Please advise with any questions.

Thanks

Dave

-----Original Message-----

From: Beckwith, Loretta A CIV USARMY CESAW (US) [mailto:Loretta.A.Beckwith@usace.army.mil]
Sent: Friday, December 29, 2017 1:19 PM
To: McHenry, David G <dgmchenry@ncdot.gov>
Subject: [External] NWP verification for SAW-2017-02437, Bridge 314 on SR 1152, Macon County

CAUTION: External email. Do not click links or open attachments unless verified. Send all suspicious email as an attachment to report.spam@nc.gov.

Dave,

By this email, NCDOT is authorized to temporarily impact 63' of Cartoogechaye Creek in order to construct work pads and impervious dikes necessary for replacement of Bridge No. 314 on SR 1152 in Macon County, North Carolina, as conditioned below. This project has been assigned USACE file #SAW-2017-02437.

Applicable Law: Section 404 (Clean Water Act, 33 USC 1344)
Authorization: Nationwide Permit Number: 33

Your work is authorized by the above referenced permit provided it is accomplished in strict accordance with the attached conditions; your submitted plans in the PCN, with the additional notes provided on November 28, 2017 (email is attached), and; the following special conditions:

Special Conditions

P-4

1. All work must be performed in strict compliance with the description of work and plans in the application dated October 6, 2017, and your submitted plans with the PCN and those with additional notes provided on November 28, 2017. Any modification to the description of work and/or the permit plans must be approved by the USACE prior to implementation.
2. The permittee shall ensure that all tree removal activities take place from October 15th to April 15th of any year.
3. The permittee shall inspect the bridge for signs of bat use immediately prior to bridge removal activities. If bats, or signs of bats, are found to be present, the permittee shall stop all bridge demolition work and contact the USACE and the Asheville USFWS for further instructions. If bats are present, the demolition may not commence until coordination/consultation is completed.
4. The permittee shall require its contractors and/or agents to comply with the terms and conditions of this authorization letter in the construction and maintenance of this project, and shall provide each of its contractors and/or agents associated with the construction or maintenance of this project with a copy of this authorization letter, all conditions, and any authorized modifications. A copy of this authorization letter, all conditions, and any authorized modifications, shall be available at the project site during construction and maintenance of this project.

Any violation of the attached conditions or deviation from your submitted plans may subject the permittee to a stop work order, a restoration order, a Class I administrative penalty, and/or appropriate legal action.

This verification will remain valid until the expiration date identified below unless the nationwide authorization is modified, suspended or revoked. If, prior to the expiration date identified below, the nationwide permit authorization is reissued and/or modified, this verification will remain valid until the expiration date identified below, provided it complies with all requirements of the modified nationwide permit. If the nationwide permit authorization expires or is suspended, revoked, or is modified, such that the activity would no longer comply with the terms and conditions of the nationwide permit, activities which have commenced (i.e., are under construction) or are under contract to commence in reliance upon the nationwide permit, will remain authorized provided the activity is completed within twelve months of the date of the nationwide permit's expiration, modification or revocation, unless discretionary authority has been exercised on a case-by-case basis to modify, suspend or revoke the authorization.

Activities subject to Section 404 (as indicated above) may also require an individual Section 401 Water Quality Certification. You should contact the NC Division of Water Resources (telephone 828-296-4500) to determine Section 401 requirements.

This Department of the Army verification does not relieve the permittee of the responsibility to obtain any other required Federal, State or local approvals/permits.

If there are any questions regarding this verification, any of the conditions of the Permit, or the Corps of Engineers regulatory program, please contact me at 828-271-7980, ext. 4223.

Expiration Date of Verification: March 18, 2022

Thank you,

Lori

Lori Beckwith
Regulatory Project Manager
U.S. Army Corps of Engineers
Wilmington District
Asheville Regulatory Field Office

Adams, Frederick C

From: McHenry, David G
Sent: Tuesday, November 28, 2017 7:46 AM
To: Beckwith, Loretta A CIV USARMY CESAW (US)
Subject: [EXTERNAL] RE: [External] USACE questions re PCN for Bridge 314 in Macon Co.
Attachments: Macon 314 permit plans_modified November 28 2017.pdf

Follow Up Flag: Follow up
Flag Status: Flagged

Lori,

Detail was not in the application, as it should have been, and though the plan shows the entire channel being impacted, this will not be the case. My apology. This project got pushed forward unexpectedly since we would like it done before the R-57334A project nearby; this road may be needed for a temporary detour. So, I should have provided better information.

Anyway, the consultant originally indicated no permit would be needed, but after speaking with construction folks I realized that unfortunately there was no way that center pier would come down without a pad where a track-hoe could easily reach it. I anticipate a single pad/stage, but I am not real sure which side would be best to access the creek from, though I suspect the east side. So, would you be okay with referencing the attached revised plans with notation concerning a maximum causeway obstruction of 50 % of the stream channel? Please advise if you need revised drawings or something else.

Sorry for the oversight.

Dave

-----Original Message-----

From: Beckwith, Loretta A CIV USARMY CESAW (US) [mailto:Loretta.A.Beckwith@usace.army.mil]
Sent: Friday, November 24, 2017 10:20 AM
To: McHenry, David G <dgmchenry@ncdot.gov>
Subject: [External] USACE questions re PCN for Bridge 314 in Macon Co.

CAUTION: External email. Do not click links or open attachments unless verified. Send all suspicious email as an attachment to report.spam@nc.gov.

Hi Dave,

I reviewed the PCN for Bridge 314 in Macon County and just have a question about the temporary fill/work pad in the stream.

Will the work pad be placed in the stream in stages? It looks like it will span the river and I didn't see any stages/phases on the plans (e.g., put in Phase I that will span 50% of the river, then remove Phase I and put in Phase II, or something

P-6

like that). I may have missed this information... If not constructed in stages/phases, how will this avoid adversely affecting the flow? If it will be put in in stages/phases, where is that information on the plans or in the PCN? I may have missed this information - if so, please point me in the right direction.

I'll be out of the office on Monday and Tuesday, so just let me know if you'd like to discuss this and I'll call you after 1200 on Wednesday.

Thank you,

Lori

Email correspondence to and from this sender is subject to the N.C. Public Records Law and may be disclosed to third parties.

**NATIONWIDE PERMIT 33
DEPARTMENT OF THE ARMY
CORPS OF ENGINEERS
FINAL NOTICE OF ISSUANCE AND MODIFICATION OF NATIONWIDE PERMITS
FEDERAL REGISTER
AUTHORIZED MARCH 19, 2017**

Temporary Construction, Access, and Dewatering. Temporary structures, work, and discharges, including cofferdams, necessary for construction activities or access fills or dewatering of construction sites, provided that the associated primary activity is authorized by the Corps of Engineers or the U.S. Coast Guard. This NWP also authorizes temporary structures, work, and discharges, including cofferdams, necessary for construction activities not otherwise subject to the Corps or U.S. Coast Guard permit requirements. Appropriate measures must be taken to maintain near normal downstream flows and to minimize flooding. Fill must consist of materials, and be placed in a manner, that will not be eroded by expected high flows. The use of dredged material may be allowed if the district engineer determines that it will not cause more than minimal adverse environmental effects. Following completion of construction, temporary fill must be entirely removed to an area that has no waters of the United States, dredged material must be returned to its original location, and the affected areas must be restored to pre- construction elevations. The affected areas must also be revegetated, as appropriate. This permit does not authorize the use of cofferdams to dewater wetlands or other aquatic areas to change their use. Structures left in place after construction is completed require a separate section 10 permit if located in navigable waters of the United States. (See 33 CFR part 322.)

***Notification:** The permittee must submit a pre-construction notification to the district engineer prior to commencing the activity if the activity is conducted in navigable waters of the United States (i.e., section 10 waters) (see general condition 32). The pre- construction notification must include a restoration plan showing how all temporary fills and structures will be removed and the area restored to pre-project conditions. (Authorities: Sections 10 and 404)

NATIONWIDE PERMIT GENERAL CONDITIONS

The following General Conditions must be followed in order for any authorization by a NWP to be valid:

1. Navigation. (a) No activity may cause more than a minimal adverse effect on navigation.
(b) Any safety lights and signals prescribed by the U.S. Coast Guard, through regulations or otherwise, must be installed and maintained at the permittee's expense on authorized facilities in navigable waters of the United States.
(c) The permittee understands and agrees that, if future operations by the United States require the removal, relocation, or other alteration, of the structure or work herein authorized, or if, in the opinion of the Secretary of the Army or his authorized representative, said structure or work shall cause unreasonable obstruction to the free navigation of the navigable waters, the permittee will be required, upon due notice from the Corps of Engineers, to remove, relocate, or alter the structural work or obstructions caused thereby, without expense to the United States. No claim shall be made against the United States on account of any such removal or alteration.
2. Aquatic Life Movements. No activity may substantially disrupt the necessary life cycle movements of those species of aquatic life indigenous to the waterbody, including those species that normally migrate through the area, unless the activity's primary purpose is to impound water. All permanent and temporary crossings of waterbodies shall be suitably culverted, bridged, or otherwise designed and constructed to maintain low flows to sustain the movement of those aquatic species. If a bottomless culvert cannot be used, then the crossing should be designed and constructed to minimize adverse effects to aquatic life movements.
3. Spawning Areas. Activities in spawning areas during spawning seasons must be avoided to the maximum extent practicable. Activities that result in the physical destruction (e.g., through excavation, fill, or downstream smothering by substantial turbidity) of an important spawning area are not authorized.
4. Migratory Bird Breeding Areas. Activities in waters of the United States that serve as breeding areas for migratory birds must be avoided to the maximum extent practicable.
5. Shellfish Beds. No activity may occur in areas of concentrated shellfish populations, unless the activity is directly related to a shellfish harvesting activity authorized by NWPs 4 and 48, or is a shellfish seeding or habitat restoration activity authorized by NWP 27.
6. Suitable Material. No activity may use unsuitable material (e.g., trash, debris, car bodies, asphalt, etc.). Material used for construction or discharged must be free from toxic pollutants in toxic amounts (see section 307 of the Clean Water Act).

7. Water Supply Intakes. No activity may occur in the proximity of a public water supply intake, except where the activity is for the repair or improvement of public water supply intake structures or adjacent bank stabilization.

8. Adverse Effects From Impoundments. If the activity creates an impoundment of water, adverse effects to the aquatic system due to accelerating the passage of water, and/or restricting its flow must be minimized to the maximum extent practicable.

9. Management of Water Flows. To the maximum extent practicable, the pre-construction course, condition, capacity, and location of open waters must be maintained for each activity, including stream channelization, storm water management activities, and temporary and permanent road crossings, except as provided below. The activity must be constructed to withstand expected high flows. The activity must not restrict or impede the passage of normal or high flows, unless the primary purpose of the activity is to impound water or manage high flows. The activity may alter the pre-construction course, condition, capacity, and location of open waters if it benefits the aquatic environment (e.g., stream restoration or relocation activities).

10. Fills Within 100-Year Floodplains. The activity must comply with applicable FEMA-approved state or local floodplain management requirements.

11. Equipment. Heavy equipment working in wetlands or mudflats must be placed on mats, or other measures must be taken to minimize soil disturbance.

12. Soil Erosion and Sediment Controls. Appropriate soil erosion and sediment controls must be used and maintained in effective operating condition during construction, and all exposed soil and other fills, as well as any work below the ordinary high water mark or high tide line, must be permanently stabilized at the earliest practicable date. Permittees are encouraged to perform work within waters of the United States during periods of low-flow or no-flow, or during low tides.

13. Removal of Temporary Fills. Temporary fills must be removed in their entirety and the affected areas returned to pre-construction elevations. The affected areas must be revegetated, as appropriate.

14. Proper Maintenance. Any authorized structure or fill shall be properly maintained, including maintenance to ensure public safety and compliance with applicable NWP general conditions, as well as any activity-specific conditions added by the district engineer to an NWP authorization.

15. Single and Complete Project. The activity must be a single and complete project. The same NWP cannot be used more than once for the same single and complete project.

16. Wild and Scenic Rivers. (a) No NWP activity may occur in a component of the National Wild and Scenic River System, or in a river officially designated by Congress as a “study river” for possible inclusion in the system while the river is in an official study status,

unless the appropriate Federal agency with direct management responsibility for such river, has determined in writing that the proposed activity will not adversely affect the Wild and Scenic River designation or study status.

(b) If a proposed NWP activity will occur in a component of the National Wild and Scenic River System, or in a river officially designated by Congress as a “study river” for possible inclusion in the system while the river is in an official study status, the permittee must submit a pre-construction notification (see general condition 32). The district engineer will coordinate the PCN with the Federal agency with direct management responsibility for that river. The permittee shall not begin the NWP activity until notified by the district engineer that the Federal agency with direct management responsibility for that river has determined in writing that the proposed NWP activity will not adversely affect the Wild and Scenic River designation or study status.

(c) Information on Wild and Scenic Rivers may be obtained from the appropriate Federal land management agency responsible for the designated Wild and Scenic River or study river (e.g., National Park Service, U.S. Forest Service, Bureau of Land Management, U.S. Fish and Wildlife Service). Information on these rivers is also available at: <http://www.rivers.gov/>.

17. Tribal Rights. No NWP activity may cause more than minimal adverse effects on tribal rights (including treaty rights), protected tribal resources, or tribal lands.

18. Endangered Species. (a) No activity is authorized under any NWP which is likely to directly or indirectly jeopardize the continued existence of a threatened or endangered species or a species proposed for such designation, as identified under the Federal Endangered Species Act (ESA), or which will directly or indirectly destroy or adversely modify the critical habitat of such species. No activity is authorized under any NWP which “may affect” a listed species or critical habitat, unless ESA section 7 consultation addressing the effects of the proposed activity has been completed. Direct effects are the immediate effects on listed species and critical habitat caused by the NWP activity. Indirect effects are those effects on listed species and critical habitat that are caused by the NWP activity and are later in time, but still are reasonably certain to occur.

(b) Federal agencies should follow their own procedures for complying with the requirements of the ESA. If pre-construction notification is required for the proposed activity, the Federal permittee must provide the district engineer with the appropriate documentation to demonstrate compliance with those requirements. The district engineer will verify that the appropriate documentation has been submitted. If the appropriate documentation has not been submitted, additional ESA section 7 consultation may be necessary for the activity and the respective federal agency would be responsible for fulfilling its obligation under section 7 of the ESA.

* (c) Non-federal permittees must submit a pre-construction notification to the district engineer if any listed species or designated critical habitat might be affected or is in the vicinity of the activity, or if the activity is located in designated critical habitat, and shall not begin work on the activity until notified by the district engineer that the requirements of the ESA have been satisfied and that the activity is authorized. For activities that might affect Federally-listed endangered or threatened species or designated critical habitat, the pre-construction notification must include the name(s) of the endangered or threatened species that

might be affected by the proposed activity or that utilize the designated critical habitat that might be affected by the proposed activity. The district engineer will determine whether the proposed activity “may affect” or will have “no effect” to listed species and designated critical habitat and will notify the non-Federal applicant of the Corps’ determination within 45 days of receipt of a complete pre-construction notification. In cases where the non-Federal applicant has identified listed species or critical habitat that might be affected or is in the vicinity of the activity, and has so notified the Corps, the applicant shall not begin work until the Corps has provided notification that the proposed activity will have “no effect” on listed species or critical habitat, or until ESA section 7 consultation has been completed. If the non-Federal applicant has not heard back from the Corps within 45 days, the applicant must still wait for notification from the Corps.

(d) As a result of formal or informal consultation with the FWS or NMFS the district engineer may add species-specific permit conditions to the NWP.

(e) Authorization of an activity by an NWP does not authorize the “take” of a threatened or endangered species as defined under the ESA. In the absence of separate authorization (e.g., an ESA Section 10 Permit, a Biological Opinion with “incidental take” provisions, etc.) from the FWS or the NMFS, the Endangered Species Act prohibits any person subject to the jurisdiction of the United States to take a listed species, where “take” means to harass, harm, pursue, hunt, shoot, wound, kill, trap, capture, or collect, or to attempt to engage in any such conduct. The word “harm” in the definition of “take” means an act which actually kills or injures wildlife. Such an act may include significant habitat modification or degradation where it actually kills or injures wildlife by significantly impairing essential behavioral patterns, including breeding, feeding or sheltering.

(f) If the non-federal permittee has a valid ESA section 10(a)(1)(B) incidental take permit with an approved Habitat Conservation Plan for a project or a group of projects that includes the proposed NWP activity, the non-federal applicant should provide a copy of that ESA section 10(a)(1)(B) permit with the PCN required by paragraph (c) of this general condition. The district engineer will coordinate with the agency that issued the ESA section 10(a)(1)(B) permit to determine whether the proposed NWP activity and the associated incidental take were considered in the internal ESA section 7 consultation conducted for the ESA section 10(a)(1)(B) permit. If that coordination results in concurrence from the agency that the proposed NWP activity and the associated incidental take were considered in the internal ESA section 7 consultation for the ESA section 10(a)(1)(B) permit, the district engineer does not need to conduct a separate ESA section 7 consultation for the proposed NWP activity. The district engineer will notify the non-federal applicant within 45 days of receipt of a complete pre-construction notification whether the ESA section 10(a)(1)(B) permit covers the proposed NWP activity or whether additional ESA section 7 consultation is required.

(g) Information on the location of threatened and endangered species and their critical habitat can be obtained directly from the offices of the FWS and NMFS or their world wide web pages at <http://www.fws.gov/> or <http://www.fws.gov/ipac> and <http://www.nmfs.noaa.gov/pr/species/esa/> respectively.

19. Migratory Birds and Bald and Golden Eagles. The permittee is responsible for ensuring their action complies with the Migratory Bird Treaty Act and the Bald and Golden Eagle Protection Act. The permittee is responsible for contacting appropriate local office of the U.S. Fish and Wildlife Service to determine applicable measures to reduce impacts to migratory

birds or eagles, including whether “incidental take” permits are necessary and available under the Migratory Bird Treaty Act or Bald and Golden Eagle Protection Act for a particular activity.

20. Historic Properties. (a) In cases where the district engineer determines that the activity may have the potential to cause effects to properties listed, or eligible for listing, in the National Register of Historic Places, the activity is not authorized, until the requirements of Section 106 of the National Historic Preservation Act (NHPA) have been satisfied.

(b) Federal permittees should follow their own procedures for complying with the requirements of section 106 of the National Historic Preservation Act. If pre-construction notification is required for the proposed NWP activity, the Federal permittee must provide the district engineer with the appropriate documentation to demonstrate compliance with those requirements. The district engineer will verify that the appropriate documentation has been submitted. If the appropriate documentation is not submitted, then additional consultation under section 106 may be necessary. The respective federal agency is responsible for fulfilling its obligation to comply with section 106.

* (c) Non-federal permittees must submit a pre-construction notification to the district engineer if the NWP activity might have the potential to cause effects to any historic properties listed on, determined to be eligible for listing on, or potentially eligible for listing on the National Register of Historic Places, including previously unidentified properties. For such activities, the pre-construction notification must state which historic properties might have the potential to be affected by the proposed NWP activity or include a vicinity map indicating the location of the historic properties or the potential for the presence of historic properties. Assistance regarding information on the location of, or potential for, the presence of historic properties can be sought from the State Historic Preservation Officer, Tribal Historic Preservation Officer, or designated tribal representative, as appropriate, and the National Register of Historic Places (see 33 CFR 330.4(g)). When reviewing pre-construction notifications, district engineers will comply with the current procedures for addressing the requirements of section 106 of the National Historic Preservation Act. The district engineer shall make a reasonable and good faith effort to carry out appropriate identification efforts, which may include background research, consultation, oral history interviews, sample field investigation, and field survey. Based on the information submitted in the PCN and these identification efforts, the district engineer shall determine whether the proposed NWP activity has the potential to cause effects on the historic properties. Section 106 consultation is not required when the district engineer determines that the activity does not have the potential to cause effects on historic properties (see 36 CFR 800.3(a)). Section 106 consultation is required when the district engineer determines that the activity has the potential to cause effects on historic properties. The district engineer will conduct consultation with consulting parties identified under 36 CFR 800.2(c) when he or she makes any of the following effect determinations for the purposes of section 106 of the NHPA: no historic properties affected, no adverse effect, or adverse effect. Where the non-Federal applicant has identified historic properties on which the activity might have the potential to cause effects and so notified the Corps, the non-Federal applicant shall not begin the activity until notified by the district engineer either that the activity has no potential to cause effects to historic properties or that NHPA section 106 consultation has been completed.

(d) For non-federal permittees, the district engineer will notify the prospective permittee within 45 days of receipt of a complete pre-construction notification whether NHPA section 106 consultation is required. If NHPA section 106 consultation is required, the district engineer will notify the non-Federal applicant that he or she cannot begin the activity until section 106 consultation is completed. If the non-Federal applicant has not heard back from the Corps within 45 days, the applicant must still wait for notification from the Corps.

(e) Prospective permittees should be aware that section 110k of the NHPA (54 U.S.C. 306113) prevents the Corps from granting a permit or other assistance to an applicant who, with intent to avoid the requirements of section 106 of the NHPA, has intentionally significantly adversely affected a historic property to which the permit would relate, or having legal power to prevent it, allowed such significant adverse effect to occur, unless the Corps, after consultation with the Advisory Council on Historic Preservation (ACHP), determines that circumstances justify granting such assistance despite the adverse effect created or permitted by the applicant. If circumstances justify granting the assistance, the Corps is required to notify the ACHP and provide documentation specifying the circumstances, the degree of damage to the integrity of any historic properties affected, and proposed mitigation. This documentation must include any views obtained from the applicant, SHPO/THPO, appropriate Indian tribes if the undertaking occurs on or affects historic properties on tribal lands or affects properties of interest to those tribes, and other parties known to have a legitimate interest in the impacts to the permitted activity on historic properties.

21. Discovery of Previously Unknown Remains and Artifacts. If you discover any previously unknown historic, cultural or archeological remains and artifacts while accomplishing the activity authorized by this permit, you must immediately notify the district engineer of what you have found, and to the maximum extent practicable, avoid construction activities that may affect the remains and artifacts until the required coordination has been completed. The district engineer will initiate the Federal, Tribal, and state coordination required to determine if the items or remains warrant a recovery effort or if the site is eligible for listing in the National Register of Historic Places.

22. Designated Critical Resource Waters. Critical resource waters include, NOAA-managed marine sanctuaries and marine monuments, and National Estuarine Research Reserves. The district engineer may designate, after notice and opportunity for public comment, additional waters officially designated by a state as having particular environmental or ecological significance, such as outstanding national resource waters or state natural heritage sites. The district engineer may also designate additional critical resource waters after notice and opportunity for public comment.

(a) Discharges of dredged or fill material into waters of the United States are not authorized by NWPs 7, 12, 14, 16, 17, 21, 29, 31, 35, 39, 40, 42, 43, 44, 49, 50, 51, and 52 for any activity within, or directly affecting, critical resource waters, including wetlands adjacent to such waters.

(b) For NWPs 3, 8, 10, 13, 15, 18, 19, 22, 23, 25, 27, 28, 30, 33, 34, 36, 37, 38, and 54, notification is required in accordance with general condition 32, for any activity proposed in the designated critical resource waters including wetlands adjacent to those waters. The district engineer may authorize activities under these NWPs only after it is determined that the impacts to the critical resource waters will be no more than minimal.

23. Mitigation. The district engineer will consider the following factors when determining appropriate and practicable mitigation necessary to ensure that the individual and cumulative adverse environmental effects are no more than minimal:

(a) The activity must be designed and constructed to avoid and minimize adverse effects, both temporary and permanent, to waters of the United States to the maximum extent practicable at the project site (i.e., on site).

(b) Mitigation in all its forms (avoiding, minimizing, rectifying, reducing, or compensating for resource losses) will be required to the extent necessary to ensure that the individual and cumulative adverse environmental effects are no more than minimal.

(c) Compensatory mitigation at a minimum one-for-one ratio will be required for all wetland losses that exceed 1/10-acre and require pre-construction notification, unless the district engineer determines in writing that either some other form of mitigation would be more environmentally appropriate or the adverse environmental effects of the proposed activity are no more than minimal, and provides an activity-specific waiver of this requirement. For wetland losses of 1/10-acre or less that require pre-construction notification, the district engineer may determine on a case-by-case basis that compensatory mitigation is required to ensure that the activity results in only minimal adverse environmental effects.

(d) For losses of streams or other open waters that require pre-construction notification, the district engineer may require compensatory mitigation to ensure that the activity results in no more than minimal adverse environmental effects. Compensatory mitigation for losses of streams should be provided, if practicable, through stream rehabilitation, enhancement, or preservation, since streams are difficult-to-replace resources (see 33 CFR 332.3(e)(3)).

(e) Compensatory mitigation plans for NWP activities in or near streams or other open waters will normally include a requirement for the restoration or enhancement, maintenance, and legal protection (e.g., conservation easements) of riparian areas next to open waters. In some cases, the restoration or maintenance/protection of riparian areas may be the only compensatory mitigation required. Restored riparian areas should consist of native species. The width of the required riparian area will address documented water quality or aquatic habitat loss concerns. Normally, the riparian area will be 25 to 50 feet wide on each side of the stream, but the district engineer may require slightly wider riparian areas to address documented water quality or habitat loss concerns. If it is not possible to restore or maintain/protect a riparian area on both sides of a stream, or if the waterbody is a lake or coastal waters, then restoring or maintaining/protecting a riparian area along a single bank or shoreline may be sufficient. Where both wetlands and open waters exist on the project site, the district engineer will determine the appropriate compensatory mitigation (e.g., riparian areas and/or wetlands compensation) based on what is best for the aquatic environment on a watershed basis. In cases where riparian areas are determined to be the most appropriate form of minimization or compensatory mitigation, the district engineer may waive or reduce the requirement to provide wetland compensatory mitigation for wetland losses.

(f) Compensatory mitigation projects provided to offset losses of aquatic resources must comply with the applicable provisions of 33 CFR part 332.

(1) The prospective permittee is responsible for proposing an appropriate compensatory mitigation option if compensatory mitigation is necessary to ensure that the activity results in no more than minimal adverse environmental effects. For the NWPs, the preferred mechanism for providing compensatory mitigation is mitigation bank credits or in-

lieu fee program credits (see 33 CFR 332.3(b)(2) and (3)). However, if an appropriate number and type of mitigation bank or in-lieu credits are not available at the time the PCN is submitted to the district engineer, the district engineer may approve the use of permittee-responsible mitigation.

(2) The amount of compensatory mitigation required by the district engineer must be sufficient to ensure that the authorized activity results in no more than minimal individual and cumulative adverse environmental effects (see 33 CFR 330.1(e)(3)). (See also 33 CFR 332.3(f)).

(3) Since the likelihood of success is greater and the impacts to potentially valuable uplands are reduced, aquatic resource restoration should be the first compensatory mitigation option considered for permittee-responsible mitigation.

(4) If permittee-responsible mitigation is the proposed option, the prospective permittee is responsible for submitting a mitigation plan. A conceptual or detailed mitigation plan may be used by the district engineer to make the decision on the NWP verification request, but a final mitigation plan that addresses the applicable requirements of 33 CFR 332.4(c)(2) through (14) must be approved by the district engineer before the permittee begins work in waters of the United States, unless the district engineer determines that prior approval of the final mitigation plan is not practicable or not necessary to ensure timely completion of the required compensatory mitigation (see 33 CFR 332.3(k)(3)).

(5) If mitigation bank or in-lieu fee program credits are the proposed option, the mitigation plan only needs to address the baseline conditions at the impact site and the number of credits to be provided.

(6) Compensatory mitigation requirements (e.g., resource type and amount to be provided as compensatory mitigation, site protection, ecological performance standards, monitoring requirements) may be addressed through conditions added to the NWP authorization, instead of components of a compensatory mitigation plan (see 33 CFR 332.4(c)(1)(ii)).

(g) Compensatory mitigation will not be used to increase the acreage losses allowed by the acreage limits of the NWPs. For example, if an NWP has an acreage limit of 1/2-acre, it cannot be used to authorize any NWP activity resulting in the loss of greater than 1/2-acre of waters of the United States, even if compensatory mitigation is provided that replaces or restores some of the lost waters. However, compensatory mitigation can and should be used, as necessary, to ensure that an NWP activity already meeting the established acreage limits also satisfies the no more than minimal impact requirement for the NWPs.

(h) Permittees may propose the use of mitigation banks, in-lieu fee programs, or permittee-responsible mitigation. When developing a compensatory mitigation proposal, the permittee must consider appropriate and practicable options consistent with the framework at 33 CFR 332.3(b). For activities resulting in the loss of marine or estuarine resources, permittee-responsible mitigation may be environmentally preferable if there are no mitigation banks or in-lieu fee programs in the area that have marine or estuarine credits available for sale or transfer to the permittee. For permittee-responsible mitigation, the special conditions of the NWP verification must clearly indicate the party or parties responsible for the implementation and performance of the compensatory mitigation project, and, if required, its long-term management.

(i) Where certain functions and services of waters of the United States are permanently adversely affected by a regulated activity, such as discharges of dredged or fill

material into waters of the United States that will convert a forested or scrub-shrub wetland to a herbaceous wetland in a permanently maintained utility line right-of-way, mitigation may be required to reduce the adverse environmental effects of the activity to the no more than minimal level.

24. Safety of Impoundment Structures. To ensure that all impoundment structures are safely designed, the district engineer may require non-Federal applicants to demonstrate that the structures comply with established state dam safety criteria or have been designed by qualified persons. The district engineer may also require documentation that the design has been independently reviewed by similarly qualified persons, and appropriate modifications made to ensure safety.

25. Water Quality. Where States and authorized Tribes, or EPA where applicable, have not previously certified compliance of an NWP with CWA section 401, individual 401 Water Quality Certification must be obtained or waived (see 33 CFR 330.4(c)). The district engineer or State or Tribe may require additional water quality management measures to ensure that the authorized activity does not result in more than minimal degradation of water quality.

26. Coastal Zone Management. In coastal states where an NWP has not previously received a state coastal zone management consistency concurrence, an individual state coastal zone management consistency concurrence must be obtained, or a presumption of concurrence must occur (see 33 CFR 330.4(d)). The district engineer or a State may require additional measures to ensure that the authorized activity is consistent with state coastal zone management requirements.

27. Regional and Case-By-Case Conditions. The activity must comply with any regional conditions that may have been added by the Division Engineer (see 33 CFR 330.4(e)) and with any case specific conditions added by the Corps or by the state, Indian Tribe, or U.S. EPA in its section 401 Water Quality Certification, or by the state in its Coastal Zone Management Act consistency determination.

28. Use of Multiple Nationwide Permits. The use of more than one NWP for a single and complete project is prohibited, except when the acreage loss of waters of the United States authorized by the NWPs does not exceed the acreage limit of the NWP with the highest specified acreage limit. For example, if a road crossing over tidal waters is constructed under NWP 14, with associated bank stabilization authorized by NWP 13, the maximum acreage loss of waters of the United States for the total project cannot exceed 1/3-acre.

29. Transfer of Nationwide Permit Verifications. If the permittee sells the property associated with a nationwide permit verification, the permittee may transfer the nationwide permit verification to the new owner by submitting a letter to the appropriate Corps district office to validate the transfer. A copy of the nationwide permit verification must be attached to the letter, and the letter must contain the following statement and signature:
“When the structures or work authorized by this nationwide permit are still in existence at the time the property is transferred, the terms and conditions of this nationwide permit, including any special conditions, will continue to be binding on the new owner(s) of the property. To

validate the transfer of this nationwide permit and the associated liabilities associated with compliance with its terms and conditions, have the transferee sign and date below.”

(Transferee)

(Date)

* 30. Compliance Certification. Each permittee who receives an NWP verification letter from the Corps must provide a signed certification documenting completion of the authorized activity and implementation of any required compensatory mitigation. The success of any required permittee-responsible mitigation, including the achievement of ecological performance standards, will be addressed separately by the district engineer. The Corps will provide the permittee the certification document with the NWP verification letter. The certification document will include:

(a) A statement that the authorized activity was done in accordance with the NWP authorization, including any general, regional, or activity-specific conditions;

(b) A statement that the implementation of any required compensatory mitigation was completed in accordance with the permit conditions. If credits from a mitigation bank or in-lieu fee program are used to satisfy the compensatory mitigation requirements, the certification must include the documentation required by 33 CFR 332.3(l)(3) to confirm that the permittee secured the appropriate number and resource type of credits; and

(c) The signature of the permittee certifying the completion of the activity and mitigation.

The completed certification document must be submitted to the district engineer within 30 days of completion of the authorized activity or the implementation of any required compensatory mitigation, whichever occurs later.

* 31. Activities Affecting Structures or Works Built by the United States. If an NWP activity also requires permission from the Corps pursuant to 33 U.S.C. 408 because it will alter or temporarily or permanently occupy or use a U.S. Army Corps of Engineers (USACE) federally authorized Civil Works project (a “USACE project”), the prospective permittee must submit a pre-construction notification. See paragraph (b)(10) of general condition 32. An activity that requires section 408 permission is not authorized by NWP until the appropriate Corps office issues the section 408 permission to alter, occupy, or use the USACE project, and the district engineer issues a written NWP verification.

* 32. Pre-Construction Notification. (a) Timing. Where required by the terms of the NWP, the prospective permittee must notify the district engineer by submitting a pre-construction notification (PCN) as early as possible. The district engineer must determine if the PCN is complete within 30 calendar days of the date of receipt and, if the PCN is determined to be incomplete, notify the prospective permittee within that 30 day period to request the additional information necessary to make the PCN complete. The request must specify the information needed to make the PCN complete. As a general rule, district engineers will request additional information necessary to make the PCN complete only once. However, if the

prospective permittee does not provide all of the requested information, then the district engineer will notify the prospective permittee that the PCN is still incomplete and the PCN review process will not commence until all of the requested information has been received by the district engineer. The prospective permittee shall not begin the activity until either:

(1) He or she is notified in writing by the district engineer that the activity may proceed under the NWP with any special conditions imposed by the district or division engineer; or

(2) 45 calendar days have passed from the district engineer's receipt of the complete PCN and the prospective permittee has not received written notice from the district or division engineer. However, if the permittee was required to notify the Corps pursuant to general condition 18 that listed species or critical habitat might be affected or are in the vicinity of the activity, or to notify the Corps pursuant to general condition 20 that the activity might have the potential to cause effects to historic properties, the permittee cannot begin the activity until receiving written notification from the Corps that there is "no effect" on listed species or "no potential to cause effects" on historic properties, or that any consultation required under Section 7 of the Endangered Species Act (see 33 CFR 330.4(f)) and/or section 106 of the National Historic Preservation Act (see 33 CFR 330.4(g)) has been completed. Also, work cannot begin under NWPs 21, 49, or 50 until the permittee has received written approval from the Corps. If the proposed activity requires a written waiver to exceed specified limits of an NWP, the permittee may not begin the activity until the district engineer issues the waiver. If the district or division engineer notifies the permittee in writing that an individual permit is required within 45 calendar days of receipt of a complete PCN, the permittee cannot begin the activity until an individual permit has been obtained. Subsequently, the permittee's right to proceed under the NWP may be modified, suspended, or revoked only in accordance with the procedure set forth in 33 CFR 330.5(d)(2).

(b) Contents of Pre-Construction Notification: The PCN must be in writing and include the following information:

(1) Name, address and telephone numbers of the prospective permittee;

(2) Location of the proposed activity;

(3) Identify the specific NWP or NWP(s) the prospective permittee wants to use to authorize the proposed activity;

(4) A description of the proposed activity; the activity's purpose; direct and indirect adverse environmental effects the activity would cause, including the anticipated amount of loss of wetlands, other special aquatic sites, and other waters expected to result from the NWP activity, in acres, linear feet, or other appropriate unit of measure; a description of any proposed mitigation measures intended to reduce the adverse environmental effects caused by the proposed activity; and any other NWP(s), regional general permit(s), or individual permit(s) used or intended to be used to authorize any part of the proposed project or any related activity, including other separate and distant crossings for linear projects that require Department of the Army authorization but do not require pre-construction notification. The description of the proposed activity and any proposed mitigation measures should be sufficiently detailed to allow the district engineer to determine that the adverse environmental effects of the activity will be no more than minimal and to determine the need for compensatory mitigation or other mitigation measures. For single and complete linear projects, the PCN must include the quantity of anticipated losses of wetlands, other special aquatic sites, and other waters for each single and complete crossing of those wetlands, other special aquatic sites, and other waters.

Sketches should be provided when necessary to show that the activity complies with the terms of the NWP. (Sketches usually clarify the activity and when provided results in a quicker decision. Sketches should contain sufficient detail to provide an illustrative description of the proposed activity (e.g., a conceptual plan), but do not need to be detailed engineering plans);

(5) The PCN must include a delineation of wetlands, other special aquatic sites, and other waters, such as lakes and ponds, and perennial, intermittent, and ephemeral streams, on the project site. Wetland delineations must be prepared in accordance with the current method required by the Corps. The permittee may ask the Corps to delineate the special aquatic sites and other waters on the project site, but there may be a delay if the Corps does the delineation, especially if the project site is large or contains many wetlands, other special aquatic sites, and other waters. Furthermore, the 45 day period will not start until the delineation has been submitted to or completed by the Corps, as appropriate;

(6) If the proposed activity will result in the loss of greater than 1/10-acre of wetlands and a PCN is required, the prospective permittee must submit a statement describing how the mitigation requirement will be satisfied, or explaining why the adverse environmental effects are no more than minimal and why compensatory mitigation should not be required. As an alternative, the prospective permittee may submit a conceptual or detailed mitigation plan.

(7) For non-Federal permittees, if any listed species or designated critical habitat might be affected or is in the vicinity of the activity, or if the activity is located in designated critical habitat, the PCN must include the name(s) of those endangered or threatened species that might be affected by the proposed activity or utilize the designated critical habitat that might be affected by the proposed activity. For NWP activities that require pre-construction notification, Federal permittees must provide documentation demonstrating compliance with the Endangered Species Act;

(8) For non-Federal permittees, if the NWP activity might have the potential to cause effects to a historic property listed on, determined to be eligible for listing on, or potentially eligible for listing on, the National Register of Historic Places, the PCN must state which historic property might have the potential to be affected by the proposed activity or include a vicinity map indicating the location of the historic property. For NWP activities that require pre-construction notification, Federal permittees must provide documentation demonstrating compliance with section 106 of the National Historic Preservation Act;

(9) For an activity that will occur in a component of the National Wild and Scenic River System, or in a river officially designated by Congress as a “study river” for possible inclusion in the system while the river is in an official study status, the PCN must identify the Wild and Scenic River or the “study river” (see general condition 16); and

(10) For an activity that requires permission from the Corps pursuant to 33 U.S.C. 408 because it will alter or temporarily or permanently occupy or use a U.S. Army Corps of Engineers federally authorized civil works project, the pre-construction notification must include a statement confirming that the project proponent has submitted a written request for section 408 permission from the Corps office having jurisdiction over that USACE project.

(c) Form of Pre-Construction Notification: The standard individual permit application form (Form ENG 4345) may be used, but the completed application form must clearly indicate that it is an NWP PCN and must include all of the applicable information required in paragraphs (b)(1) through (10) of this general condition. A letter containing the required information may also be used. Applicants may provide electronic files of PCNs and

supporting materials if the district engineer has established tools and procedures for electronic submittals.

(d) Agency Coordination: (1) The district engineer will consider any comments from Federal and state agencies concerning the proposed activity's compliance with the terms and conditions of the NWPs and the need for mitigation to reduce the activity's adverse environmental effects so that they are no more than minimal.

(2) Agency coordination is required for: (i) all NWP activities that require pre-construction notification and result in the loss of greater than 1/2-acre of waters of the United States; (ii) NWP 21, 29, 39, 40, 42, 43, 44, 50, 51, and 52 activities that require pre-construction notification and will result in the loss of greater than 300 linear feet of stream bed; (iii) NWP 13 activities in excess of 500 linear feet, fills greater than one cubic yard per running foot, or involve discharges of dredged or fill material into special aquatic sites; and (iv) NWP 54 activities in excess of 500 linear feet, or that extend into the waterbody more than 30 feet from the mean low water line in tidal waters or the ordinary high water mark in the Great Lakes.

(3) When agency coordination is required, the district engineer will immediately provide (e.g., via e-mail, facsimile transmission, overnight mail, or other expeditious manner) a copy of the complete PCN to the appropriate Federal or state offices (FWS, state natural resource or water quality agency, EPA, and, if appropriate, the NMFS). With the exception of NWP 37, these agencies will have 10 calendar days from the date the material is transmitted to notify the district engineer via telephone, facsimile transmission, or e-mail that they intend to provide substantive, site-specific comments. The comments must explain why the agency believes the adverse environmental effects will be more than minimal. If so contacted by an agency, the district engineer will wait an additional 15 calendar days before making a decision on the pre-construction notification. The district engineer will fully consider agency comments received within the specified time frame concerning the proposed activity's compliance with the terms and conditions of the NWPs, including the need for mitigation to ensure the net adverse environmental effects of the proposed activity are no more than minimal. The district engineer will provide no response to the resource agency, except as provided below. The district engineer will indicate in the administrative record associated with each pre-construction notification that the resource agencies' concerns were considered. For NWP 37, the emergency watershed protection and rehabilitation activity may proceed immediately in cases where there is an unacceptable hazard to life or a significant loss of property or economic hardship will occur. The district engineer will consider any comments received to decide whether the NWP 37 authorization should be modified, suspended, or revoked in accordance with the procedures at 33 CFR 330.5.

(4) In cases of where the prospective permittee is not a Federal agency, the district engineer will provide a response to NMFS within 30 calendar days of receipt of any Essential Fish Habitat conservation recommendations, as required by section 305(b)(4)(B) of the Magnuson-Stevens Fishery Conservation and Management Act.

(5) Applicants are encouraged to provide the Corps with either electronic files or multiple copies of pre-construction notifications to expedite agency coordination.

DISTRICT ENGINEER'S DECISION

1. In reviewing the PCN for the proposed activity, the district engineer will determine whether the activity authorized by the NWP will result in more than minimal

individual or cumulative adverse environmental effects or may be contrary to the public interest. If a project proponent requests authorization by a specific NWP, the district engineer should issue the NWP verification for that activity if it meets the terms and conditions of that NWP, unless he or she determines, after considering mitigation, that the proposed activity will result in more than minimal individual and cumulative adverse effects on the aquatic environment and other aspects of the public interest and exercises discretionary authority to require an individual permit for the proposed activity. For a linear project, this determination will include an evaluation of the individual crossings of waters of the United States to determine whether they individually satisfy the terms and conditions of the NWP(s), as well as the cumulative effects caused by all of the crossings authorized by NWP. If an applicant requests a waiver of the 300 linear foot limit on impacts to streams or of an otherwise applicable limit, as provided for in NWPs 13, 21, 29, 36, 39, 40, 42, 43, 44, 50, 51, 52, or 54, the district engineer will only grant the waiver upon a written determination that the NWP activity will result in only minimal individual and cumulative adverse environmental effects. For those NWPs that have a waivable 300 linear foot limit for losses of intermittent and ephemeral stream bed and a 1/2-acre limit (i.e., NWPs 21, 29, 39, 40, 42, 43, 44, 50, 51, and 52), the loss of intermittent and ephemeral stream bed, plus any other losses of jurisdictional waters and wetlands, cannot exceed 1/2-acre.

2. When making minimal adverse environmental effects determinations the district engineer will consider the direct and indirect effects caused by the NWP activity. He or she will also consider the cumulative adverse environmental effects caused by activities authorized by NWP and whether those cumulative adverse environmental effects are no more than minimal. The district engineer will also consider site specific factors, such as the environmental setting in the vicinity of the NWP activity, the type of resource that will be affected by the NWP activity, the functions provided by the aquatic resources that will be affected by the NWP activity, the degree or magnitude to which the aquatic resources perform those functions, the extent that aquatic resource functions will be lost as a result of the NWP activity (e.g., partial or complete loss), the duration of the adverse effects (temporary or permanent), the importance of the aquatic resource functions to the region (e.g., watershed or ecoregion), and mitigation required by the district engineer. If an appropriate functional or condition assessment method is available and practicable to use, that assessment method may be used by the district engineer to assist in the minimal adverse environmental effects determination. The district engineer may add case-specific special conditions to the NWP authorization to address site-specific environmental concerns.

3. If the proposed activity requires a PCN and will result in a loss of greater than 1/10-acre of wetlands, the prospective permittee should submit a mitigation proposal with the PCN. Applicants may also propose compensatory mitigation for NWP activities with smaller impacts, or for impacts to other types of waters (e.g., streams). The district engineer will consider any proposed compensatory mitigation or other mitigation measures the applicant has included in the proposal in determining whether the net adverse environmental effects of the proposed activity are no more than minimal. The compensatory mitigation proposal may be either conceptual or detailed. If the district engineer determines that the activity complies with the terms and conditions of the NWP and that the adverse environmental effects are no more than minimal, after considering mitigation, the district engineer will notify the permittee and

include any activity-specific conditions in the NWP verification the district engineer deems necessary. Conditions for compensatory mitigation requirements must comply with the appropriate provisions at 33 CFR 332.3(k). The district engineer must approve the final mitigation plan before the permittee commences work in waters of the United States, unless the district engineer determines that prior approval of the final mitigation plan is not practicable or not necessary to ensure timely completion of the required compensatory mitigation. If the prospective permittee elects to submit a compensatory mitigation plan with the PCN, the district engineer will expeditiously review the proposed compensatory mitigation plan. The district engineer must review the proposed compensatory mitigation plan within 45 calendar days of receiving a complete PCN and determine whether the proposed mitigation would ensure the NWP activity results in no more than minimal adverse environmental effects. If the net adverse environmental effects of the NWP activity (after consideration of the mitigation proposal) are determined by the district engineer to be no more than minimal, the district engineer will provide a timely written response to the applicant. The response will state that the NWP activity can proceed under the terms and conditions of the NWP, including any activity-specific conditions added to the NWP authorization by the district engineer.

4. If the district engineer determines that the adverse environmental effects of the proposed activity are more than minimal, then the district engineer will notify the applicant either: (a) that the activity does not qualify for authorization under the NWP and instruct the applicant on the procedures to seek authorization under an individual permit; (b) that the activity is authorized under the NWP subject to the applicant's submission of a mitigation plan that would reduce the adverse environmental effects so that they are no more than minimal; or (c) that the activity is authorized under the NWP with specific modifications or conditions. Where the district engineer determines that mitigation is required to ensure no more than minimal adverse environmental effects, the activity will be authorized within the 45-day PCN period (unless additional time is required to comply with general conditions 18, 20, and/or 31, or to evaluate PCNs for activities authorized by NWPs 21, 49, and 50), with activity-specific conditions that state the mitigation requirements. The authorization will include the necessary conceptual or detailed mitigation plan or a requirement that the applicant submit a mitigation plan that would reduce the adverse environmental effects so that they are no more than minimal. When compensatory mitigation is required, no work in waters of the United States may occur until the district engineer has approved a specific mitigation plan or has determined that prior approval of a final mitigation plan is not practicable or not necessary to ensure timely completion of the required compensatory mitigation.

FURTHER INFORMATION

1. District Engineers have authority to determine if an activity complies with the terms and conditions of an NWP.
2. NWPs do not obviate the need to obtain other federal, state, or local permits, approvals, or authorizations required by law.
3. NWPs do not grant any property rights or exclusive privileges.
4. NWPs do not authorize any injury to the property or rights of others.
5. NWPs do not authorize interference with any existing or proposed Federal project (see general condition 31).

DEFINITIONS

Best management practices (BMPs): Policies, practices, procedures, or structures implemented to mitigate the adverse environmental effects on surface water quality resulting from development. BMPs are categorized as structural or non-structural.

Compensatory mitigation: The restoration (re-establishment or rehabilitation), establishment (creation), enhancement, and/or in certain circumstances preservation of aquatic resources for the purposes of offsetting unavoidable adverse impacts which remain after all appropriate and practicable avoidance and minimization has been achieved.

Currently serviceable: Useable as is or with some maintenance, but not so degraded as to essentially require reconstruction.

Direct effects: Effects that are caused by the activity and occur at the same time and place.

Discharge: The term “discharge” means any discharge of dredged or fill material into waters of the United States.

Ecological reference: A model used to plan and design an aquatic habitat and riparian area restoration, enhancement, or establishment activity under NWP 27. An ecological reference may be based on the structure, functions, and dynamics of an aquatic habitat type or a riparian area type that currently exists in the region where the proposed NWP 27 activity is located. Alternatively, an ecological reference may be based on a conceptual model for the aquatic habitat type or riparian area type to be restored, enhanced, or established as a result of the proposed NWP 27 activity. An ecological reference takes into account the range of variation of the aquatic habitat type or riparian area type in the region.

Enhancement: The manipulation of the physical, chemical, or biological characteristics of an aquatic resource to heighten, intensify, or improve a specific aquatic resource function(s). Enhancement results in the gain of selected aquatic resource function(s), but may also lead to a decline in other aquatic resource function(s). Enhancement does not result in a gain in aquatic resource area.

Ephemeral stream: An ephemeral stream has flowing water only during, and for a short duration after, precipitation events in a typical year. Ephemeral stream beds are located above the water table year-round. Groundwater is not a source of water for the stream. Runoff from rainfall is the primary source of water for stream flow.

Establishment (creation): The manipulation of the physical, chemical, or biological characteristics present to develop an aquatic resource that did not previously exist at an upland site. Establishment results in a gain in aquatic resource area.

High Tide Line: The line of intersection of the land with the water’s surface at the maximum height reached by a rising tide. The high tide line may be determined, in the absence of actual data, by a line of oil or scum along shore objects, a more or less continuous deposit of fine shell or debris on the foreshore or berm, other physical markings or characteristics, vegetation lines, tidal gages, or other suitable means that delineate the general height reached by a rising tide. The line encompasses spring high tides and other high tides that occur with periodic frequency but does not include storm surges in which there is a departure from the normal or predicted reach of the tide due to the piling up of water against a coast by strong winds such as those accompanying a hurricane or other intense storm.

Historic Property: Any prehistoric or historic district, site (including archaeological site), building, structure, or other object included in, or eligible for inclusion in, the National

Register of Historic Places maintained by the Secretary of the Interior. This term includes artifacts, records, and remains that are related to and located within such properties. The term includes properties of traditional religious and cultural importance to an Indian tribe or Native Hawaiian organization and that meet the National Register criteria (36 CFR part 60).

Independent utility: A test to determine what constitutes a single and complete non-linear project in the Corps Regulatory Program. A project is considered to have independent utility if it would be constructed absent the construction of other projects in the project area. Portions of a multi-phase project that depend upon other phases of the project do not have independent utility. Phases of a project that would be constructed even if the other phases were not built can be considered as separate single and complete projects with independent utility.

Indirect effects: Effects that are caused by the activity and are later in time or farther removed in distance, but are still reasonably foreseeable.

Intermittent stream: An intermittent stream has flowing water during certain times of the year, when groundwater provides water for stream flow. During dry periods, intermittent streams may not have flowing water. Runoff from rainfall is a supplemental source of water for stream flow.

Loss of waters of the United States: Waters of the United States that are permanently adversely affected by filling, flooding, excavation, or drainage because of the regulated activity. Permanent adverse effects include permanent discharges of dredged or fill material that change an aquatic area to dry land, increase the bottom elevation of a waterbody, or change the use of a waterbody. The acreage of loss of waters of the United States is a threshold measurement of the impact to jurisdictional waters for determining whether a project may qualify for an NWP; it is not a net threshold that is calculated after considering compensatory mitigation that may be used to offset losses of aquatic functions and services. The loss of stream bed includes the acres or linear feet of stream bed that are filled or excavated as a result of the regulated activity. Waters of the United States temporarily filled, flooded, excavated, or drained, but restored to pre-construction contours and elevations after construction, are not included in the measurement of loss of waters of the United States. Impacts resulting from activities that do not require Department of the Army authorization, such as activities eligible for exemptions under section 404(f) of the Clean Water Act, are not considered when calculating the loss of waters of the United States.

Navigable waters: Waters subject to section 10 of the Rivers and Harbors Act of 1899. These waters are defined at 33 CFR part 329.

Non-tidal wetland: A non-tidal wetland is a wetland that is not subject to the ebb and flow of tidal waters. Non-tidal wetlands contiguous to tidal waters are located landward of the high tide line (i.e., spring high tide line).

Open water: For purposes of the NWPs, an open water is any area that in a year with normal patterns of precipitation has water flowing or standing above ground to the extent that an ordinary high water mark can be determined. Aquatic vegetation within the area of flowing or standing water is either non-emergent, sparse, or absent. Vegetated shallows are considered to be open waters. Examples of "open waters" include rivers, streams, lakes, and ponds.

Ordinary High Water Mark: An ordinary high water mark is a line on the shore established by the fluctuations of water and indicated by physical characteristics, or by other appropriate means that consider the characteristics of the surrounding areas.

Perennial stream: A perennial stream has flowing water year-round during a typical year. The water table is located above the stream bed for most of the year. Groundwater is the

primary source of water for stream flow. Runoff from rainfall is a supplemental source of water for stream flow.

Practicable: Available and capable of being done after taking into consideration cost, existing technology, and logistics in light of overall project purposes.

Pre-construction notification: A request submitted by the project proponent to the Corps for confirmation that a particular activity is authorized by nationwide permit. The request may be a permit application, letter, or similar document that includes information about the proposed work and its anticipated environmental effects. Pre-construction notification may be required by the terms and conditions of a nationwide permit, or by regional conditions. A pre-construction notification may be voluntarily submitted in cases where pre-construction notification is not required and the project proponent wants confirmation that the activity is authorized by nationwide permit.

Preservation: The removal of a threat to, or preventing the decline of, aquatic resources by an action in or near those aquatic resources. This term includes activities commonly associated with the protection and maintenance of aquatic resources through the implementation of appropriate legal and physical mechanisms. Preservation does not result in a gain of aquatic resource area or functions.

Protected tribal resources: Those natural resources and properties of traditional or customary religious or cultural importance, either on or off Indian lands, retained by, or reserved by or for, Indian tribes through treaties, statutes, judicial decisions, or executive orders, including tribal trust resources.

Re-establishment: The manipulation of the physical, chemical, or biological characteristics of a site with the goal of returning natural/historic functions to a former aquatic resource. Re-establishment results in rebuilding a former aquatic resource and results in a gain in aquatic resource area and functions.

Rehabilitation: The manipulation of the physical, chemical, or biological characteristics of a site with the goal of repairing natural/historic functions to a degraded aquatic resource. Rehabilitation results in a gain in aquatic resource function, but does not result in a gain in aquatic resource area.

Restoration: The manipulation of the physical, chemical, or biological characteristics of a site with the goal of returning natural/historic functions to a former or degraded aquatic resource. For the purpose of tracking net gains in aquatic resource area, restoration is divided into two categories: re-establishment and rehabilitation.

Riffle and pool complex: Riffle and pool complexes are special aquatic sites under the 404(b)(1) Guidelines. Riffle and pool complexes sometimes characterize steep gradient sections of streams. Such stream sections are recognizable by their hydraulic characteristics. The rapid movement of water over a coarse substrate in riffles results in a rough flow, a turbulent surface, and high dissolved oxygen levels in the water. Pools are deeper areas associated with riffles. A slower stream velocity, a streaming flow, a smooth surface, and a finer substrate characterize pools.

Riparian areas: Riparian areas are lands next to streams, lakes, and estuarine- marine shorelines. Riparian areas are transitional between terrestrial and aquatic ecosystems, through which surface and subsurface hydrology connects riverine, lacustrine, estuarine, and marine waters with their adjacent wetlands, non-wetland waters, or uplands. Riparian areas provide a variety of ecological functions and services and help improve or maintain local water quality. (See general condition 23.)

Shellfish seeding: The placement of shellfish seed and/or suitable substrate to increase shellfish production. Shellfish seed consists of immature individual shellfish or individual shellfish attached to shells or shell fragments (i.e., spat on shell). Suitable substrate may consist of shellfish shells, shell fragments, or other appropriate materials placed into waters for shellfish habitat.

Single and complete linear project: A linear project is a project constructed for the purpose of getting people, goods, or services from a point of origin to a terminal point, which often involves multiple crossings of one or more waterbodies at separate and distant locations. The term “single and complete project” is defined as that portion of the total linear project proposed or accomplished by one owner/developer or partnership or other association of owners/developers that includes all crossings of a single water of the United States (i.e., a single waterbody) at a specific location. For linear projects crossing a single or multiple waterbodies several times at separate and distant locations, each crossing is considered a single and complete project for purposes of NWP authorization. However, individual channels in a braided stream or river, or individual arms of a large, irregularly shaped wetland or lake, etc., are not separate waterbodies, and crossings of such features cannot be considered separately.

Single and complete non-linear project: For non-linear projects, the term “single and complete project” is defined at 33 CFR 330.2(i) as the total project proposed or accomplished by one owner/developer or partnership or other association of owners/developers. A single and complete non-linear project must have independent utility (see definition of “independent utility”). Single and complete non-linear projects may not be “piecemealed” to avoid the limits in an NWP authorization.

Stormwater management: Stormwater management is the mechanism for controlling stormwater runoff for the purposes of reducing downstream erosion, water quality degradation, and flooding and mitigating the adverse effects of changes in land use on the aquatic environment.

Stormwater management facilities: Stormwater management facilities are those facilities, including but not limited to, stormwater retention and detention ponds and best management practices, which retain water for a period of time to control runoff and/or improve the quality (i.e., by reducing the concentration of nutrients, sediments, hazardous substances and other pollutants) of stormwater runoff.

Stream bed: The substrate of the stream channel between the ordinary high water marks. The substrate may be bedrock or inorganic particles that range in size from clay to boulders. Wetlands contiguous to the stream bed, but outside of the ordinary high water marks, are not considered part of the stream bed.

Stream channelization: The manipulation of a stream’s course, condition, capacity, or location that causes more than minimal interruption of normal stream processes. A channelized stream remains a water of the United States.

Structure: An object that is arranged in a definite pattern of organization. Examples of structures include, without limitation, any pier, boat dock, boat ramp, wharf, dolphin, weir, boom, breakwater, bulkhead, revetment, riprap, jetty, artificial island, artificial reef, permanent mooring structure, power transmission line, permanently moored floating vessel, piling, aid to navigation, or any other manmade obstacle or obstruction.

Tidal wetland: A tidal wetland is a jurisdictional wetland that is inundated by tidal waters. Tidal waters rise and fall in a predictable and measurable rhythm or cycle due to the gravitational pulls of the moon and sun. Tidal waters end where the rise and fall of the water

surface can no longer be practically measured in a predictable rhythm due to masking by other waters, wind, or other effects. Tidal wetlands are located channelward of the high tide line.

Tribal lands: Any lands title to which is either: 1) held in trust by the United States for the benefit of any Indian tribe or individual; or 2) held by any Indian tribe or individual subject to restrictions by the United States against alienation.

Tribal rights: Those rights legally accruing to a tribe or tribes by virtue of inherent sovereign authority, unextinguished aboriginal title, treaty, statute, judicial decisions, executive order or agreement, and that give rise to legally enforceable remedies.

Vegetated shallows: Vegetated shallows are special aquatic sites under the 404(b)(1) Guidelines. They are areas that are permanently inundated and under normal circumstances have rooted aquatic vegetation, such as seagrasses in marine and estuarine systems and a variety of vascular rooted plants in freshwater systems.

Waterbody: For purposes of the NWPs, a waterbody is a jurisdictional water of the United States. If a wetland is adjacent to a waterbody determined to be a water of the United States, that waterbody and any adjacent wetlands are considered together as a single aquatic unit (see 33 CFR 328.4(c)(2)). Examples of “waterbodies” include streams, rivers, lakes, ponds, and wetlands.

FINAL 2017 REGIONAL CONDITIONS

NOTICE ABOUT WEB LINKS IN THIS DOCUMENT:

The web links (both internal to our Wilmington District and any external links to collaborating agencies) in this document are valid at the time of publication. However, the Wilmington District Regulatory Program web page addresses, as with other agency web sites, may change over the timeframe of the five-year Nationwide Permit renewal cycle, in response to policy mandates or technology advances. While we will make every effort to check on the integrity of our web links and provide re-direct pages whenever possible, we ask that you report any broken links to us so we can keep the page information current and usable. We apologize in advanced for any broken links that you may encounter, and we ask that you navigate from the Regulatory home page (Regulatory Permit Program Wetlands and Streams) of the Wilmington District Corps of Engineers, to the “Permits” section of our web site to find links for pages that cannot be found by clicking directly on the listed web link in this document.

Final 2017 Regional Conditions for Nationwide Permits (NWP) in the Wilmington District

1.0 Excluded Waters

The Corps has identified waters that will be excluded from the use of all NWP’s during certain timeframes. These waters are:

1.1 Anadromous Fish Spawning Areas

Waters of the United States identified by either the North Carolina Division of Marine Fisheries (NCDMF) or the North Carolina Wildlife Resources Commission (NCWRC) as anadromous fish spawning areas are excluded during the period between February 15 and June 30, without prior written approval from the Corps and either NCDMF or NCWRC.

1.2 Trout Waters Moratorium

Waters of the United States in the designated trout watersheds of North Carolina are excluded during the period between October 15 and April 15 without prior written approval from the NCWRC, or from the Eastern Band of Cherokee Indians (EBCI) Fisheries and Wildlife Management (FWM) office if the project is located on EBCI trust land. (See Section 2.7 for information on the designated trout watersheds).

1.3 Sturgeon Spawning Areas as Designated by the National Marine Fisheries Service (NMFS)

Waters of the United States designated as sturgeon spawning areas are excluded during the period between February 1 and June 30, without prior written approval from the NMFS.

* **2.0 Waters Requiring Additional Notification**

The Corps has identified waters that will be subject to additional notification requirements for activities authorized by all NWPs. These waters are:

* **2.1 Western NC Counties that Drain to Designated Critical Habitat**

For proposed activities within waters of the United States that require a Pre-Construction Notification (PCN) and are located in the sixteen counties listed below, permittees must provide a copy of the PCN to the U.S. Fish and Wildlife Service (USFWS), 160 Zillicoa Street, Asheville, North Carolina 28801. This PCN must be sent concurrently to the U.S. Fish and Wildlife Service and the Corps Asheville Regulatory Field Office. Please see General Condition 18 for specific notification requirements related to the Endangered Species Act and the below website for information on the location of designated critical habitat.

Counties with tributaries that drain to designated critical habitat that require notification to the Asheville U.S. Fish and Wildlife Service: Avery, Cherokee, Forsyth, Graham, Haywood, Henderson, Jackson, Macon, Mecklenburg, Mitchell, Stokes, Surry, Swain, Transylvania, Union and Yancey.

Website and office addresses for Endangered Species Act Information:

The Wilmington District has developed the following website for permittees which provides guidelines on how to review linked websites and maps in order to fulfill NWP General Condition 18 requirements:

<http://www.saw.usace.army.mil/Missions/RegulatoryPermitProgram/AgencyCoordination/ESA.asp>

Permittees who do not have internet access may contact the appropriate U.S. Fish and Wildlife Service offices listed below or Corps at (910) 251-4633:

Asheville U.S. Fish and Wildlife Service Office counties: All counties west of and including Anson, Stanly, Davidson, Forsythe and Stokes Counties.

U.S. Fish and Wildlife Service
Asheville Field Office
160 Zillicoa Street
Asheville, NC 28801
Telephone: (828) 258-3939

Raleigh U.S. Fish and Wildlife Service Office counties: all counties east of and including Richmond, Montgomery, Randolph, Guilford, and Rockingham Counties.

U.S. Fish and Wildlife Service
Raleigh Field Office
Post Office Box 33726

Raleigh, NC 27636-3726
Telephone: (919) 856-4520

* 2.2 Special Designation Waters

Prior to the use of any NWP, except NWP 3, that involves a discharge of dredged or fill material in any of the following identified waters and/or adjacent wetlands in North Carolina, permittees shall submit a PCN to the District Engineer prior to commencing the activity (see General Condition 32). The North Carolina waters and wetlands that require additional notification requirements are:

“Outstanding Resource Waters” (ORW) or “High Quality Waters” (HQW) as designated by the North Carolina Environmental Management Commission; “Primary Nursery Areas” (PNA), including inland PNA, as designated by the North Carolina Marine Fisheries Commission and the NCWRC; or wetlands adjacent to these waters. Definitions of ORW, HQW and PNA waters can be found in the North Carolina State Administrative Code, Title 15A, Subchapters 2B and 10C (15A NCAC 02B, 15A NCAC 10C) and at the following World Wide Web page:

<http://reports.oah.state.nc.us/ncac.asp?folderName=\Title%2015A%20-%20Environmental%20Quality&lookUpError=15A%20NCAC%20000%20>. Surface water classifications for waters in North Carolina can be viewed at the North Carolina Division of Water Resources website or at the following World Wide Web Page:

<https://deq.nc.gov/about/divisions/water-resources/planning/classification-standards/classifications>

Permittees who do not have internet access may contact the Corps at (910) 251- 4633.

2.3 Coastal Area Management Act (CAMA) Areas of Environmental Concern

Non-federal permittees for any NWP in a designated “Area of Environmental Concern” (AEC) in the twenty (20) counties of Eastern North Carolina covered by the North Carolina Coastal Area Management Act (CAMA) must also obtain the required CAMA permit. Development activities for non-federal projects may not commence until a copy of the approved CAMA permit is furnished to the appropriate Wilmington District Regulatory Field Office (Wilmington Field Office – 69 Darlington Avenue, Wilmington, NC 28403, (910) 251-4802 or Washington Field Office – 2407 West 5th Street, Washington, NC 27889, (910) 251-4610).

* 2.4 Barrier Islands

Prior to the use of any NWP on a barrier island of North Carolina, permittees must submit a PCN to the District Engineer prior to commencing the activity (see General Condition 32).

* 2.5 Mountain or Piedmont Bogs

Prior to the use of any NWP in a Bog, as classified by the North Carolina Wetland Assessment Methodology (NCWAM), permittees shall submit a PCN to the District Engineer prior to commencing the activity (see General Condition 32). The latest version of NCWAM can be

viewed on the Corps RIBITS (Regulatory In-lieu Fee and Bank Information Tracking System) website or at the following World Wide Web Page:

https://ribits.usace.army.mil/ribits_apex/f?p=107:27:0::NO::

*** 2.6 Animal Waste Facilities**

Prior to use of any NWP for construction of animal waste facilities in waters of the United States, including wetlands, permittees shall submit a PCN to the District Engineer prior to commencing the activity (see General Condition 32).

*** 2.7 Trout Waters**

Prior to any discharge of dredge or fill material into streams, waterbodies or wetlands within the 294 designated trout watersheds of North Carolina, the permittee shall submit a PCN (see General Condition 32) to the District Engineer prior to commencing the activity, unless other thresholds are established in the Regional Conditions in Section 4 (Additional Regional Conditions for Specific Nationwide Permits). The permittee shall also provide a copy of the notification to the appropriate NCWRC office, or to the EBCI FWM Office (if the project is located on EBCI trust land), to facilitate the determination of any potential impacts to designated Trout Waters.

Notification to the Corps will include a statement with the name of the NCWRC or EBCI FWM biologist contacted, the date of the notification, the location of work, a delineation of wetlands and waters, a discussion of alternatives to working in the mountain trout waters, why alternatives were not selected, and, if applicable, a plan to provide compensatory mitigation for all unavoidable adverse impacts to mountain trout waters.

NCWRC and NC Trout Watersheds:

NCWRC Contact**	Counties that are entirely within Trout Watersheds*	Counties that are partially within Trout Watersheds*
Mountain Coordinator Balsam Depot 20830 Great Smoky Mountain Expressway Waynesville, NC 28786 Telephone: (828) 558-6011 For NCDOT Projects: NCDOT Coordinator 206 Charter. Street Albemarle, NC 28001 Telephone: (704) 982-9181	Alleghany Jackson Ashe Macon Avery Swain Graham Transylvania Haywood Watauga	Burke McDowell Buncombe Mitchell Caldwell Polk Cherokee Rutherford Clay Surry Henderson Wilkes Madison Yancey

*NOTE: To determine notification requirements, contact the Corps Asheville Regulatory Field Office at (828) 271-7980 or view maps for each County at the following World Wide Web page: <http://www.saw.usace.army.mil/Missions/Regulatory-Permit-Program/Agency-Coordination/Trout/>.

**If a project is located on EBCI trust land, submit the PCN in accordance with Section 3.14. Contact the Corps Asheville Regulatory Field Office at (828) 271-7980 with questions.

* **2.8 Western NC Waters and Corridors**

The permittee shall submit a PCN (see General Condition 32) to the District Engineer prior to commencing the activity in waters of the United States if the activity will occur within any of the following identified waters in western North Carolina, within 0.5 mile on either side of these waters, or within 0.75 mile of the Little Tennessee River, as measured from the top of the bank of the respective water (i.e., river, stream, or creek):

Brasstown Creek
Burningtown Creek
Cane River
Caney Fork
Cartoogechaye Creek
Chattooga River
Cheoah River
Cowee Creek
Cullasaja River
Deep Creek
Ellijay Creek
French Broad River
Garden Creek
Hiwassee River
Hominy Creek
Iotla Creek
Little Tennessee River (within the river or within 0.75 mile on either side of this river)
Nantahala River
Nolichucky River
North Fork French Broad River
North Toe River
Nottley River
Oconaluftee River (portion not located on trust/EBCI land)
Peachtree Creek
Shooting Creek
Snowbird Creek
South Toe River
Stecoah Creek
Swannanoa River
Sweetwater Creek

Tuckasegee River (also spelled Tuckaseegee or Tuckaseigee)
Valley River
Watauga Creek
Watauga River
Wayah Creek
West Fork French Broad River

To determine notification requirements, contact the Corps Asheville Regulatory Field Office at (828) 271-7980 or view maps for all corridors at the following World Wide Web page:
<http://www.saw.usace.army.mil/Missions/Regulatory-Permit-Program/Agency-Coordination/Designated-Special-Waters.aspx>

3.0 List of Corps Regional Conditions for All Nationwide Permits

The following conditions apply to all Nationwide Permits in the Wilmington District:

3.1 Limitation of Loss of Stream Bed

NWPs may not be used for activities that may result in the loss or degradation of more than 300 total linear feet of stream bed, unless the District Engineer has waived the 300 linear foot limit for ephemeral and intermittent streams on a case-by-case basis and has determined that the proposed activity will result in minimal individual and cumulative adverse impacts to the aquatic environment. Waivers for the loss of ephemeral and intermittent streams must be in writing and documented by appropriate/accepted stream quality assessments*. This waiver only applies to the 300 linear feet threshold for NWPs.

This Regional Condition does not apply to NWP 23 (Approved Categorical Exclusions).

*NOTE: Permittees should utilize the most current methodology prescribed by Wilmington District to assess stream function and quality. Information can be found at:
https://ribits.usace.army.mil/ribits_apex/f?p=107:27:0::NO::

3.2 Mitigation for Loss of Stream Bed

For any NWP that results in a loss of more than 150 linear feet of stream, the permittee shall provide a mitigation proposal to compensate for more than minimal individual and cumulative adverse impacts to the aquatic environment. For stream losses of 150 linear feet or less that require a PCN, the District Engineer may determine, on a case-by-case basis, that compensatory mitigation is required to ensure that the activity results in minimal adverse effect on the aquatic environment.

3.3 Pre-construction Notification for Loss of Streambed Exceeding 150 Feet

Prior to use of any NWP for any activity which impacts more than 150 total linear feet of perennial stream, intermittent or ephemeral stream, the permittee shall submit a PCN to the District Engineer prior to commencing the activity (see General Condition 32). This applies to

NWPs that do not have specific notification requirements. If a NWP has specific notification requirements, the requirements of the NWP should be followed.

3.4 Restriction on Use of Live Concrete

For all NWPs which allow the use of concrete as a building material, live or fresh concrete, including bags of uncured concrete, may not come into contact with the water in or entering into waters of the United States. Water inside coffer dams or casings that has been in contact with wet concrete shall only be returned to waters of the United States after the concrete is set and cured and when it no longer poses a threat to aquatic organisms.

3.5 Requirements for Using Riprap for Bank Stabilization

For all NWPs that allow for the use of riprap material for bank stabilization, the following measures shall be applied:

3.5.1. Where bank stabilization is conducted as part of an activity, natural design, bioengineering and/or geoen지니어ing methods that incorporate natural durable materials, native seed mixes, and native plants and shrubs are to be utilized to the maximum extent practicable.

3.5.2. Filter cloth must be placed underneath the riprap as an additional requirement of its use in North Carolina waters. The placement of filter fabric is not required if the riprap will be pushed or “keyed” into the bank of the waterbody. A waiver from the specifications in this Regional Condition may be requested in writing. The waiver will only be issued if it can be demonstrated that the impacts of complying with this Regional Condition would result in greater adverse impacts to the aquatic environment.

3.5.3. The placement of riprap shall be limited to the areas depicted on submitted work plan drawings.

3.5.4. The riprap material shall be clean and free from loose dirt or any pollutant except in trace quantities that would not have an adverse environmental effect.

3.5.5. It shall be of a size sufficient to prevent its movement from the authorized alignment by natural forces under normal conditions.

3.5.6. The riprap material shall consist of clean rock or masonry material such as, but not limited to, granite, marl, or broken concrete.

3.6 Requirements for Culvert Placement

3.6.1 For all NWPs that involve the construction/installation of culverts, measures will be included in the construction/installation that will promote the safe passage of fish and other aquatic organisms. The dimension, pattern, and profile of the stream above and below a pipe or culvert should not be modified by altering the width or depth of the stream profile in connection with the construction activity. The width, height, and gradient of a proposed culvert should be

sufficient to pass the average historical low flow and spring flow without adversely altering flow velocity. Spring flow is the seasonal sustained high flow that typically occurs in the spring. Spring flows should be determined from gage data, if available. In the absence of such data, bank-full flow can be used as a comparable indicator.

In Public Trust Areas of Environmental Concern (AEC) and/or the Estuarine Waters AEC as designated by the Coastal Area Management Act (CAMA): All pipes/culverts must be sufficiently sized to allow for the burial of the bottom of the culvert at least one foot below normal bed elevation.

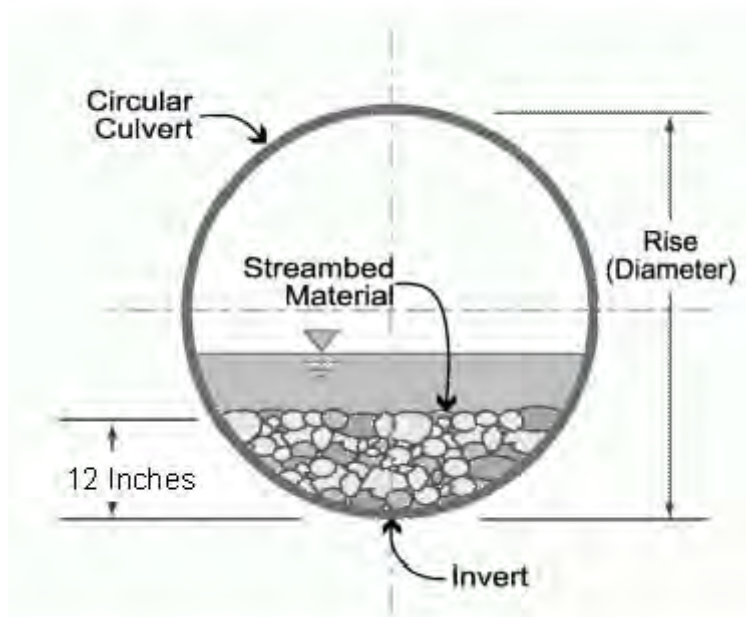

In all other areas: Culverts greater than 48 inches in diameter will be buried at least one foot below the bed of the stream. Culverts 48 inches in diameter or less shall be buried to maintain aquatic passage and to maintain passage during drought or low flow conditions, and every effort shall be made to maintain the existing channel slope.

Culverts must be designed and constructed in a manner that minimizes destabilization and head cutting. Destabilizing the channel and head cutting upstream should be considered and appropriate actions incorporated in the design and placement of the culvert.

A waiver from the depth specifications in this condition may be requested, in writing, by the permittee and issued by the Corp; this request must be specific as to the reasons(s) for the request. The waiver will be issued if it can be demonstrated that the proposed design would result in less impacts to the aquatic environment.

All counties: Culverts placed within riparian and/or riverine wetlands must be installed in a manner that does not restrict the flow and circulation patterns of waters of the United States.

Culverts placed across wetland fills purely for the purposes of equalizing surface water do not have to be buried, but the culverts must be of adequate size and/or number to ensure unrestricted transmission of water.

3.6.2 Bank-full flows (or less) shall be accommodated through maintenance of the existing bank-full channel cross sectional area. Additional culverts or culvert barrels at such crossings shall be allowed only to receive bank-full flows.

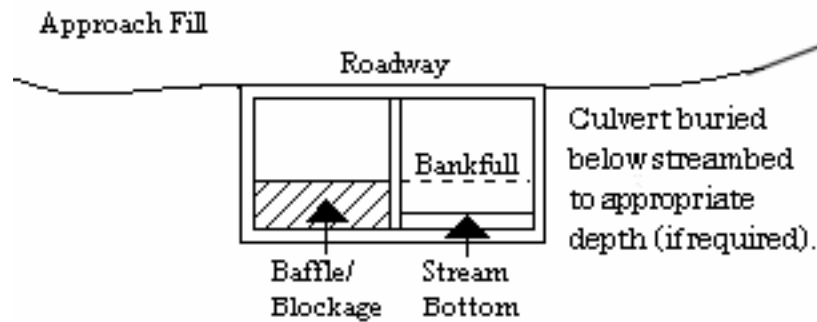

3.6.3 Where adjacent floodplain is available, flows exceeding bank-full should be accommodated by installing culverts at the floodplain elevation. Additional culverts or culvert barrels at such crossings should not be buried, or if buried, must have sills at the inlets to ensure that they only receive flows exceeding bank-full.

3.6.4 Excavation of existing stream channels shall be limited to the minimum necessary to construct or install the proposed culvert. The final width of the impacted stream at the culvert inlet and outlet should be no greater than the original stream width. A waiver from this condition may be requested in writing; this request must be specific as to the reason(s) for the request. The waiver will be issued if the proposed design would result in less impacts to the aquatic environment and/or if it can be demonstrated that it is not practicable to restore the final width of the impacted stream at the culvert inlet and outlet to the width of the original stream channel.

3.6.5 The width of the culvert shall be comparable to the width of the stream channel. If the width of the culvert is wider than the stream channel, the culvert shall include baffles, benches and/or sills to maintain the width of the stream channel. A waiver from this condition may be requested in writing; this request must be specific as to the reason(s) for the request. The waiver will be issued if it can be demonstrated that it is not practicable or necessary to include baffles, benches or sills and the design would result in less impacts to the aquatic environment.

3.7 Notification to NCDEQ Shellfish Sanitation Section

Permittees shall notify the NCDEQ Shellfish Sanitation Section prior to dredging in or removing sediment from an area closed to shell fishing where the effluent may be released to an area open for shell fishing or swimming in order to avoid contamination from the disposal area and cause a temporary shellfish closure to be made. Such notification shall also be provided to the appropriate Corps Regulatory Field Office. Any disposal of sand to the ocean beach should occur between November 1 and April 30 when recreational usage is low. Only clean sand

should be used and no dredged sand from closed shell fishing areas may be used. If beach disposal were to occur at times other than stated above or if sand from a closed shell fishing area is to be used, a swimming advisory shall be posted, and a press release shall be issued by the permittee.

3.8 Submerged Aquatic Vegetation

Impacts to Submerged Aquatic Vegetation (SAV) are not authorized by any NWP, except NWP 48, unless EFH Consultation has been completed pursuant to the Magnuson-Stevens Fisheries Conservation and Management Act (Magnuson-Stevens Act). Permittees shall submit a PCN (See NWP General Condition 32) to the District Engineer prior to commencing the activity if the project would affect SAV. The permittee may not begin work until notified by the Corps that the requirements of the Magnuson-Stevens Act have been satisfied and that the activity is authorized.

3.9 Sedimentation and Erosion Control Structures and Measures

All PCNs will identify and describe sedimentation and erosion control structures and measures proposed for placement in waters of the United States. The structures and measures should be depicted on maps, surveys or drawings showing location and impacts to jurisdictional wetlands and streams.

3.10 Restoration of Temporary Impacts to Stream Beds

Upon completion of work that involves temporary stream impacts, streambeds are to be restored to pre-project elevations and widths using natural streambed material such that the impacted stream reach mimics the adjacent upstream and downstream reach. The impacted area shall be backfilled with natural streambed material to a depth of at least 12 inches or to the bottom depth of the impacted area if shallower than 12 inches. An engineered in-stream structure or material can be used to provide protection of a buried structure if it provides benefits to the aquatic environment and can be accomplished by a natural streambed design. A permittee may request a waiver of this condition if it is determined a buried structure needs significant physical protection beyond those provided in this condition. This condition does not apply to NWP 27 – Aquatic Habitat Restoration, Enhancement, and Establishment Activities.

3.11 Restoration of Temporary Impacts to Stream Banks

Upon completion of work involving temporary stream bank impacts, stream banks are to be restored to pre-project grade and contours or beneficial grade and contours if the original bank slope is steep and unstable. Natural durable materials, native seed mixes, and native plants and shrubs are to be utilized in the restoration. Natural designs which use bioengineered and/or geo-engineered methods are to be applied. An engineered structure or material can be used to provide protection of a buried structure if it provides benefits to the stream bank environment, provided it is not in excess of the minimum amount needed for protection and does not exceed an average of one cubic yard per running foot placed along the bank below the plane of the ordinary high water mark. A permittee may request a waiver of this condition if it is determined a buried structure

needs significant physical protection beyond those provided in this condition. This condition does not apply to NWP 27 – Aquatic Habitat Restoration, Enhancement, and Establishment Activities.

3.12 Federal Navigation Channel Setbacks and Corps Easements

3.12.1 Authorized structures and fills located in or adjacent to Federally authorized waterways will be constructed in accordance with the latest setback criteria established by the Wilmington District Engineer. You may review the setback policy at <http://www.saw.usace.army.mil/Missions/Navigation/Setbacks.aspx>. This general permit does not authorize the construction of hardened or permanently fixed structures within the Federally Authorized Channel Setback, unless the activity is approved by the Corps. The permittee shall submit a PCN (see General Condition 32) to the District Engineer prior to the construction of any structures or fills within the Federally Authorized Channel Setback.

3.12.2 The permittee shall obtain a Consent to Cross Government Easement from the Wilmington District's Land Use Coordinator prior to any crossing of the Corps easement and/or prior to commencing construction of any structures, authorized dredging or other work within the right-of-way of, or in proximity to, a federally designated disposal area. The Land Use Coordinator may be contacted at: CESAW-OP-N, 69 Darlington Avenue, Wilmington, North Carolina 28403-1343, email: SAWWeb-NAV@usace.army.mil

3.13 Northern Long-eared Bat – Endangered Species Act Compliance

The Wilmington District, U.S. Army Corps of Engineers has consulted with the United States Fish and Wildlife Service (USFWS) in regards to the threatened Northern long-eared bat (NLEB) (*Myotis septentrionalis*) and Standard Local Operating Procedures for Endangered Species (SLOPES) have been approved by the Corps and the USFWS. This condition concerns effects to the NLEB only and does not address effects to other federally listed species and/or federally designated critical habitat.

A. Procedures when the Corps is the lead federal* agency for a project:

The permittee must comply with (1) and (2) below when:

- the project is located in the western 41 counties of North Carolina, to include non-federal aid North Carolina Department of Transportation (NCDOT) projects, OR;
- the project is located in the 59 eastern counties of North Carolina, and is a non-NCDOT project.

*Generally, if a project is located on private property or on non-federal land, and the project is not being funded by a federal entity, the Corps will be the lead federal agency due to the requirement to obtain Department of the Army authorization to impact waters of the United States. If the project is located on federal land, contact the Corps to determine the lead federal agency.

(1) A permittee using a NWP must check to see if their project is located in the range of the NLEB by using the following website:

<http://www.fws.gov/midwest/endangered/mammals/nleb/pdf/WNSZone.pdf>. If the project is within the range of the NLEB, or if the project includes percussive activities (e.g., blasting, pile driving, etc.), the permittee is then required to check the appropriate website in the paragraph below to discover if their project:

- is located in a 12-digit Hydrologic Unit Code area (“red HUC” - shown as red areas on the map), AND/OR;
- involves percussive activities within 0.25 mile of a red HUC.

Red HUC maps - for the western 41 counties in NC (covered by the Asheville Ecological Services Field Office), check the project location against the electronic maps found at: http://www.fws.gov/asheville/htmls/project_review/NLEB_in_WNC.html. For the eastern 59 counties in NC (covered by the Raleigh Ecological Services Field Office), check the project location against the electronic maps found at:

https://www.fws.gov/raleigh/NLEB_RFO.html.

(2) A permittee must submit a PCN to the District Engineer, and receive written authorization from the District Engineer, prior to commencing the activity, if the activity will involve any of the following:

- tree clearing/removal, construction/installation of wind turbines in a red HUC, AND/OR;
- bridge removal or maintenance, unless the bridge has been inspected and there is no evidence of bat use, (applies anywhere in the range of the NLEB), AND/OR;
- percussive activities in a red HUC, or within 0.25 mile of a red HUC.

The permittee may proceed with the activity without submitting a PCN to either the Corps or the USFWS, provided the activity complies with all applicable NWP terms and general and regional conditions, if the permittee’s review under A.(1) and A.(2) above shows that the project is:

- located outside of a red HUC (and there are no percussive activities), and the activity will NOT include bridge removal or maintenance, unless the bridge has been inspected and there is no evidence of bat use, OR;
- located outside of a red HUC and there are percussive activities, but the percussive activities will not occur within 0.25-mile of a red HUC boundary, and the activity will NOT include bridge removal or maintenance, unless the bridge has been inspected and there is no evidence of bat use, OR;

- located in a red HUC, but the activity will NOT include: tree clearing/removal; construction/installation of wind turbines; bridge removal or maintenance, unless the bridge has been inspected and there is no evidence of bat use, and/or; any percussive activities.

B. Procedures when the USACE is not the lead federal agency:

For projects where another federal agency is the lead federal agency - if that other federal agency has completed project-specific ESA Section 7(a)(2) consultation for the NLEB, and has (1) determined that the project would not cause prohibited incidental take of the NLEB, and (2) completed coordination/consultation that is required by the USFWS (per the directions on the respective USFWS office's website), that project may proceed without notification to either the USACE or the USFWS, provided all General and Regional Permit Conditions are met.

The NLEB SLOPES can be viewed on the USACE website at the following World Wide Web Page: <http://www.saw.usace.army.mil/Missions/Regulatory-Permit-Program/Agency-Coordination/ESA/>. Permittees who do not have internet access may contact the USACE at (910) 251- 4633.

3.14 Work on Eastern Band of Cherokee Indians Land

All PCNs submitted for activities in waters of the United States on Eastern Band of Cherokee Indians (EBCI) trust land (i.e., Qualla Boundary and non-contiguous tracts of trust land), must comply with the requirements of the latest MOU between the Wilmington District and the Eastern Band of Cherokee Indians.

4.0 Additional Regional Conditions for Specific Nationwide Permits

4.1 NWP #33 – Temporary Construction, Access, and Dewatering

4.1.1 The permittee shall submit a PCN to the District Engineer prior to commencing the activity if the activity will involve the discharge of dredged or fill material into more than 1/10-acre of wetlands or 150 linear feet of stream channel for the construction of temporary access fills and/or temporary road crossings.

4.1.2 For activities that require a PCN, the PCN must include a restoration plan that thoroughly describes how all temporary fills will be removed, describes how pre-project conditions will be restored, and includes a timetable for all restoration activities.

STATE OF NORTH CAROLINA
DEPARTMENT OF ENVIRONMENTAL QUALITY
DIVISION OF WATER RESOURCES

WATER QUALITY GENERAL CERTIFICATION NO. 4141

GENERAL CERTIFICATION FOR PROJECTS ELIGIBLE FOR US ARMY CORPS OF ENGINEERS

- **NATIONWIDE PERMIT NUMBER 33 (TEMPORARY CONSTRUCTION, ACCESS AND DEWATERING)**

Water Quality Certification Number 4141 is issued in conformity with the requirements of Section 401, Public Laws 92-500 and 95-217 of the United States and subject to the North Carolina Regulations in 15A NCAC 02H .0500 and 15A NCAC 02B .0200 for the discharge of fill material to surface waters and wetland areas as described in 33 CFR 330 Appendix A (B) (33) of the US Army Corps of Engineers regulations.

The State of North Carolina certifies that the specified category of activity will not violate applicable portions of Sections 301, 302, 303, 306 and 307 of the Public Laws 92-500 and 95-217 if conducted in accordance with the conditions hereinafter set forth.

Effective date: December 1, 2017

Signed this day: December 1, 2017

By

A handwritten signature in black ink, appearing to read 'Linda Culpepper', is written over a horizontal line.

for Linda Culpepper
Interim Director

P-43
GC4141

Activities meeting any one (1) of the following thresholds or circumstances require written approval for a 401 Water Quality Certification from the Division of Water Resources (DWR):

- a) If any of the conditions of this Certification (listed below) cannot be met; or
- b) Any permanent fill into or modification of wetlands and/or waters; or
- c) Total temporary impacts to streams greater than 150 feet; or
- d) Total temporary impacts to wetlands greater than 0.10 acre; or
- e) Any stream relocation or stream restoration; or
- f) Complete dewatering and drawdowns to a sediment layer related to pond/dam maintenance or removal; or
- g) Any permanent impacts to waters, or to wetlands adjacent to waters, designated as: ORW (including SAV), HQW (including PNA), SA, WS-I, WS-II, Trout, or North Carolina or National Wild and Scenic River; or
- h) Any permanent impacts to coastal wetlands [15A NCAC 07H .0205], or Unique Wetlands (UWL); or
- i) Any impact associated with a Notice of Violation or an enforcement action for violation(s) of NC Wetland Rules (15A NCAC 02H .0500), NC Isolated Wetland Rules (15A NCAC 02H .1300), NC Surface Water or Wetland Standards (15A NCAC 02B .0200), or State Regulated Riparian Buffer Rules (15A NCAC 02B .0200); or
- * j) Any impacts to subject water bodies and/or state regulated riparian buffers along subject water bodies in the Neuse, Tar-Pamlico, or Catawba River Basins or in the Randleman Lake, Jordan Lake or Goose Creek Watersheds (or any other basin or watershed with State Regulated Riparian Area Protection Rules [Buffer Rules] in effect at the time of application) *unless*:
 - i. The activities are listed as “EXEMPT” from these rules; or
 - ii. A Buffer Authorization Certificate is issued by the NC Division of Coastal Management (DCM); or
 - iii. A Buffer Authorization Certificate or a Minor Variance is issued by a delegated or designated local government implementing a state riparian buffer program pursuant to 143-215.23.

Activities included in this General Certification that do not meet one of the thresholds listed above do not require written approval.

I. ACTIVITY SPECIFIC CONDITIONS:

1. For all dam removal projects meeting the definition under G.S. 143-215.25 and requirements under G.S. 143-215.27 of a professionally supervised dam removal, the applicant shall provide documentation that any sediment that may be released has similar or lower level of contamination than sediment sampled from downstream of the dam in accordance with Session Law 2017-145.

II. GENERAL CONDITIONS:

1. When written authorization is required, the plans and specifications for the project are incorporated into the authorization by reference and are an enforceable part of the Certification. Any modifications to the project require notification to DWR and may require an application submittal to DWR with the appropriate fee. [15A NCAC 02H .0501 and .0502]
2. No waste, spoil, solids, or fill of any kind shall occur in wetlands or waters beyond the footprint of the impacts (including temporary impacts) as authorized in the written approval from DWR; or beyond the thresholds established for use of this Certification without written authorization. [15A NCAC 02H .0501 and .0502]

No removal of vegetation or other impacts of any kind shall occur to state regulated riparian buffers beyond the footprint of impacts approved in a Buffer Authorization or Variance or as listed as an exempt activity in the applicable riparian buffer rules. [15A NCAC 02B .0200]

- * 3. In accordance with 15A NCAC 02H .0506(h) and Session Law 2017-10, compensatory mitigation may be required for losses of greater than 300 linear feet of perennial streams and/or greater than one (1) acre of wetlands. Impacts associated with the removal of a dam shall not require mitigation when the removal complies with the requirements of Part 3 of Article 21 in Chapter 143 of the North Carolina General Statutes. Impacts to isolated and other non-404 jurisdictional wetlands shall not be combined with 404 jurisdictional wetlands for the purpose of determining when impact thresholds trigger a mitigation requirement. For linear publicly owned and maintained transportation projects that are not determined to be part of a larger common plan of development by the US Army Corps of Engineers, compensatory mitigation may be required for losses of greater than 300 linear feet per perennial stream.

Compensatory stream and/or wetland mitigation shall be proposed and completed in compliance with G.S. 143-214.11. For applicants proposing to conduct mitigation within a project site, a complete mitigation proposal developed in accordance with the most recent guidance issued by the US Army Corps of Engineers Wilmington District shall be submitted for review and approval with the application for impacts.

4. All activities shall be in compliance with any applicable State Regulated Riparian Buffer Rules in Chapter 2 of Title 15A.
5. When applicable, all construction activities shall be performed and maintained in full compliance with G.S. Chapter 113A Article 4 (Sediment and Pollution Control Act of 1973). Regardless of applicability of the Sediment and Pollution Control Act, all projects shall incorporate appropriate Best Management Practices for the control of sediment and erosion so that no violations of state water quality standards, statutes, or rules occur. [15A NCAC 02H .0506 (b)(3) and (c)(3) and 15A NCAC 02B .0200].

Design, installation, operation, and maintenance of all sediment and erosion control measures shall be equal to or exceed the requirements specified in the most recent version

P-45
GC4141

of the *North Carolina Sediment and Erosion Control Manual*, or for linear transportation projects, the *NCDOT Sediment and Erosion Control Manual*.

All devices shall be maintained on all construction sites, borrow sites, and waste pile (spoil) sites, including contractor-owned or leased borrow pits associated with the project. Sufficient materials required for stabilization and/or repair of erosion control measures and stormwater routing and treatment shall be on site at all times.

For borrow pit sites, the erosion and sediment control measures shall be designed, installed, operated, and maintained in accordance with the most recent version of the *North Carolina Surface Mining Manual*. Reclamation measures and implementation shall comply with the reclamation in accordance with the requirements of the Sedimentation Pollution Control Act and the Mining Act of 1971.

If the project occurs in waters or watersheds classified as Primary Nursery Areas (PNAs), SA, WS-I, WS-II, High Quality (HQW), or Outstanding Resource waters (ORW), then the sedimentation and erosion control designs shall comply with the requirements set forth in 15A NCAC 04B .0124, *Design Standards in Sensitive Watersheds*.

6. Sediment and erosion control measures shall not be placed in wetlands or waters except within the footprint of temporary or permanent impacts authorized under this Certification. Exceptions to this condition require application to and written approval from DWR. [15A NCAC 02H .0501 and .0502]
7. Erosion control matting that incorporates plastic mesh and/or plastic twine shall not be used along streambanks or within wetlands. Exceptions to this condition require application to and written approval from DWR. [15A NCAC 02B .0201]
8. An NPDES Construction Stormwater Permit (NCG010000) is required for construction projects that disturb one (1) or more acres of land. The NCG010000 Permit allows stormwater to be discharged during land disturbing construction activities as stipulated in the conditions of the permit. If the project is covered by this permit, full compliance with permit conditions including the erosion & sedimentation control plan, inspections and maintenance, self-monitoring, record keeping and reporting requirements is required. [15A NCAC 02H .0506(b)(5) and (c)(5)]

The North Carolina Department of Transportation (NCDOT) shall be required to be in full compliance with the conditions related to construction activities within the most recent version of their individual NPDES (NCS000250) stormwater permit. [15A NCAC 02H .0506(b)(5) and (c)(5)]

9. All work in or adjacent to streams shall be conducted so that the flowing stream does not come in contact with the disturbed area. Approved best management practices from the most current version of the *NC Sediment and Erosion Control Manual*, or the *NC DOT Construction and Maintenance Activities Manual*, such as sandbags, rock berms, cofferdams, and other diversion structures shall be used to minimize excavation in flowing

P-46 GC4141

water. Exceptions to this condition require application to and written approval from DWR. [15A NCAC 02H .0506(b)(3) and (c)(3)]

10. If activities must occur during periods of high biological activity (e.g. sea turtle nesting, fish spawning, or bird nesting), then biological monitoring may be required at the request of other state or federal agencies and coordinated with these activities. [15A NCAC 02H .0506 (b)(2) and 15A NCAC 04B .0125]

All moratoriums on construction activities established by the NC Wildlife Resources Commission (WRC), US Fish and Wildlife Service (USFWS), NC Division of Marine Fisheries (DMF), or National Marine Fisheries Service (NMFS) shall be implemented. Exceptions to this condition require written approval by the resource agency responsible for the given moratorium. A copy of the approval from the resource agency shall be forwarded to DWR.

Work within a designated trout watershed of North Carolina (as identified by the Wilmington District of the US Army Corps of Engineers), or identified state or federal endangered or threatened species habitat, shall be coordinated with the appropriate WRC, USFWS, NMFS, and/or DMF personnel.

11. Culverts shall be designed and installed in such a manner that the original stream profiles are not altered and allow for aquatic life movement during low flows. The dimension, pattern, and profile of the stream above and below a pipe or culvert shall not be modified by widening the stream channel or by reducing the depth of the stream in connection with the construction activity. The width, height, and gradient of a proposed culvert shall be such as to pass the average historical low flow and spring flow without adversely altering flow velocity. [15A NCAC 02H .0506(b)(2) and (c)(2)]

Placement of culverts and other structures in streams shall be below the elevation of the streambed by one foot for all culverts with a diameter greater than 48 inches, and 20% of the culvert diameter for culverts having a diameter less than or equal to 48 inches, to allow low flow passage of water and aquatic life.

If multiple pipes or barrels are required, they shall be designed to mimic the existing stream cross section as closely as possible including pipes or barrels at flood plain elevation and/or sills where appropriate. Widening the stream channel shall be avoided.

When topographic constraints indicate culvert slopes of greater than 5%, culvert burial is not required, provided that all alternative options for flattening the slope have been investigated and aquatic life movement/connectivity has been provided when possible (e.g. rock ladders, cross vanes, etc.). Notification, including supporting documentation to include a location map of the culvert, culvert profile drawings, and slope calculations, shall be provided to DWR 60 calendar days prior to the installation of the culvert.

P-47
GC4141

When bedrock is present in culvert locations, culvert burial is not required provided that there is sufficient documentation of the presence of bedrock. Notification, including supporting documentation such as, a location map of the culvert, geotechnical reports, photographs, etc. shall be provided to DWR a minimum of 60 calendar days prior to the installation of the culvert. If bedrock is discovered during construction, then DWR shall be notified by phone or email within 24 hours of discovery.

If other site-specific topographic constraints preclude the ability to bury the culverts as described above and/or it can be demonstrated that burying the culvert would result in destabilization of the channel, then exceptions to this condition require application to and written approval from DWR.

Installation of culverts in wetlands shall ensure continuity of water movement and be designed to adequately accommodate high water or flood conditions. When roadways, causeways, or other fill projects are constructed across FEMA-designated floodways or wetlands, openings such as culverts or bridges shall be provided to maintain the natural hydrology of the system as well as prevent constriction of the floodway that may result in destabilization of streams or wetlands.

The establishment of native woody vegetation and other soft stream bank stabilization techniques shall be used where practicable instead of rip-rap or other bank hardening methods.

12. Bridge deck drains shall not discharge directly into the stream. Stormwater shall be directed across the bridge and pre-treated through site-appropriate means to the maximum extent practicable (e.g. grassed swales, pre-formed scour holes, vegetated buffers, etc.) before entering the stream. Exceptions to this condition require application to and written approval from DWR. [15A NCAC 02H .0506(b)(5)]
13. Application of fertilizer to establish planted/seeded vegetation within disturbed riparian areas and/or wetlands shall be conducted at agronomic rates and shall comply with all other Federal, State and Local regulations. Fertilizer application shall be accomplished in a manner that minimizes the risk of contact between the fertilizer and surface waters. [15A NCAC 02B .0200 and 15A NCAC 02B .0231]
14. If concrete is used during construction, then all necessary measures shall be taken to prevent direct contact between uncured or curing concrete and waters of the state. Water that inadvertently contacts uncured concrete shall not be discharged to waters of the state. [15A NCAC 02B .0200]
15. All proposed and approved temporary fill and culverts shall be removed and the impacted area shall be returned to natural conditions within 60 calendar days after the temporary impact is no longer necessary. The impacted areas shall be restored to original grade, including each stream's original cross sectional dimensions, planform pattern, and longitudinal bed profile. For projects that receive written approval, no temporary impacts are allowed beyond those included in the application and authorization. All temporarily

P-48
GC4141

impacted sites shall be restored and stabilized with native vegetation. [15A NCAC 02H .0506(b)(2) and (c)(2)]

16. All proposed and approved temporary pipes/culverts/rip-rap pads etc. in streams shall be installed as outlined in the most recent edition of the *North Carolina Sediment and Erosion Control Planning and Design Manual* or the *North Carolina Surface Mining Manual* or the *North Carolina Department of Transportation Best Management Practices for Construction and Maintenance Activities* so as not to restrict stream flow or cause dis-equilibrium during use of this Certification. [15A NCAC 02H .0506(b)(2) and (c)(2)]
17. Any rip-rap required for proper culvert placement, stream stabilization, or restoration of temporarily disturbed areas shall be restricted to the area directly impacted by the approved construction activity. All rip-rap shall be placed such that the original stream elevation and streambank contours are restored and maintained. Placement of rip-rap or other approved materials shall not result in de-stabilization of the stream bed or banks upstream or downstream of the area or in a manner that precludes aquatic life passage. [15A NCAC 02H .0506(b)(2)]
18. Any rip-rap used for stream or shoreline stabilization shall be of a size and density to prevent movement by wave, current action, or stream flows and shall consist of clean rock or masonry material free of debris or toxic pollutants. Rip-rap shall not be installed in the streambed except in specific areas required for velocity control and to ensure structural integrity of bank stabilization measures. [15A NCAC 02H .0506(b)(2)]
19. Applications for rip-rap groins proposed in accordance with 15A NCAC 07H .1401 (NC Division of Coastal Management General Permit for construction of Wooden and Rip-rap Groins in Estuarine and Public Trust Waters) shall meet all the specific conditions for design and construction specified in 15A NCAC 07H .1405.
20. All mechanized equipment operated near surface waters shall be inspected and maintained regularly to prevent contamination of surface waters from fuels, lubricants, hydraulic fluids, or other toxic materials. Construction shall be staged in order to minimize the exposure of equipment to surface waters to the maximum extent practicable. Fueling, lubrication and general equipment maintenance shall be performed in a manner to prevent, to the maximum extent practicable, contamination of surface waters by fuels and oils. [15A NCAC 02H .0506(b)(3) and (c)(3) and 15A NCAC 02B .0211 (12)]
21. Heavy equipment working in wetlands shall be placed on mats or other measures shall be taken to minimize soil disturbance. [15A NCAC 02H .0506(b)(3) and (c)(3)]
22. In accordance with 143-215.85(b), the applicant shall report any petroleum spill of 25 gallons or more; any spill regardless of amount that causes a sheen on surface waters; any petroleum spill regardless of amount occurring within 100 feet of surface waters; and any petroleum spill less than 25 gallons that cannot be cleaned up within 24 hours.

P-49
GC4141

- * 23. If an environmental document is required under the State Environmental Policy Act (SEPA), then this General Certification is not valid until a Finding of No Significant Impact (FONSI) or Record of Decision (ROD) is issued by the State Clearinghouse. If an environmental document is required under the National Environmental Policy Act (NEPA), then this General Certification is not valid until a Categorical Exclusion, the Final Environmental Assessment, or Final Environmental Impact Statement is published by the lead agency. [15A NCAC 01C .0107(a)]
24. This General Certification does not relieve the applicant of the responsibility to obtain all other required Federal, State, or Local approvals before proceeding with your project, including those required by, but not limited to, Sediment and Erosion Control, Non-Discharge, Water Supply Watershed, and Trout Buffer regulations.
25. The applicant and their authorized agents shall conduct all activities in a manner consistent with State water quality standards (including any requirements resulting from compliance with §303(d) of the Clean Water Act), and any other appropriate requirements of State and Federal Law. If DWR determines that such standards or laws are not being met, including failure to sustain a designated or achieved use, or that State or Federal law is being violated, or that further conditions are necessary to assure compliance, then DWR may revoke or modify a written authorization associated with this General Water Quality Certification. [15A NCAC 02H .0507(d)]
26. The permittee shall require its contractors and/or agents to comply with the terms and conditions of this permit in the construction and maintenance of this project, and shall provide each of its contractors and/or agents associated with the construction or maintenance of this project with a copy of this Certification. A copy of this Certification, including all conditions shall be available at the project site during the construction and maintenance of this project. [15A NCAC 02H .0507 (c) and 15A NCAC 02H .0506 (b)(2) and (c)(2)]
- * 27. When written authorization is required for use of this Certification, upon completion of all permitted impacts included within the approval and any subsequent modifications, the applicant shall be required to return a certificate of completion (available on the DWR website <https://edocs.deq.nc.gov/Forms/Certificate-of-Completion>). [15A NCAC 02H .0502(f)]
28. Additional site-specific conditions, including monitoring and/or modeling requirements, may be added to the written approval letter for projects proposed under this Water Quality Certification in order to ensure compliance with all applicable water quality and effluent standards. [15A NCAC 02H .0507(c)]
29. If the property or project is sold or transferred, the new permittee shall be given a copy of this Certification (and written authorization if applicable) and is responsible for complying with all conditions. [15A NCAC 02H .0501 and .0502]

P-50
GC4141

II. GENERAL CERTIFICATION ADMINISTRATION:

- * 1. In accordance with North Carolina General Statute 143-215.3D(e), written approval for a 401 Water Quality General Certification must include the appropriate fee. An applicant for a CAMA permit under Article 7 of Chapter 113A of the General Statutes for which a Water Quality Certification is required shall only make one payment to satisfy both agencies; the fee shall be as established by the Secretary in accordance with 143-215.3D(e)(7).
2. This Certification neither grants nor affirms any property right, license, or privilege in any waters, or any right of use in any waters. This Certification does not authorize any person to interfere with the riparian rights, littoral rights, or water use rights of any other person and this Certification does not create any prescriptive right or any right of priority regarding any usage of water. This Certification shall not be interposed as a defense in any action respecting the determination of riparian or littoral rights or other rights to water use. No consumptive user is deemed by virtue of this Certification to possess any prescriptive or other right of priority with respect to any other consumptive user regardless of the quantity of the withdrawal or the date on which the withdrawal was initiated or expanded.
3. This Certification grants permission to the Director, an authorized representative of the Director, or DWR staff, upon the presentation of proper credentials, to enter the property during normal business hours. [15A NCAC 02H .0502(e)]
4. This General Certification shall expire on the same day as the expiration date of the corresponding Nationwide Permit and/or Regional General Permit. The conditions in effect on the date of issuance of Certification for a specific project shall remain in effect for the life of the project, regardless of the expiration date of this Certification. This General Certification is rescinded when the US Army Corps of Engineers reauthorizes any of the corresponding Nationwide Permits and/or Regional General Permits or when deemed appropriate by the Director of the Division of Water Resources.
5. Non-compliance with or violation of the conditions herein set forth by a specific project may result in revocation of this General Certification for the project and may also result in criminal and/or civil penalties.
- * 6. The Director of the North Carolina Division of Water Resources may require submission of a formal application for Individual Certification for any project in this category of activity if it is deemed in the public's best interest or determined that the project is likely to have a significant adverse effect upon water quality, including state or federally listed endangered or threatened aquatic species, or degrade the waters so that existing uses of the water or downstream waters are precluded.

History Note: Water Quality Certification (WQC) Number 4141 issued December 1, 2017 replaces WQC4094 issued March 3, 2017; WQC 3893 issued March 19, 2012; WQC Number 3688 issued November 1, 2007; WQC Number 3634 issued March 19, 2007; WQC Number 3366 issued March 18, 2002; WQC Number 3114 issued February 11, 1997; and WQC Number 2727 issued May 1, 1992.

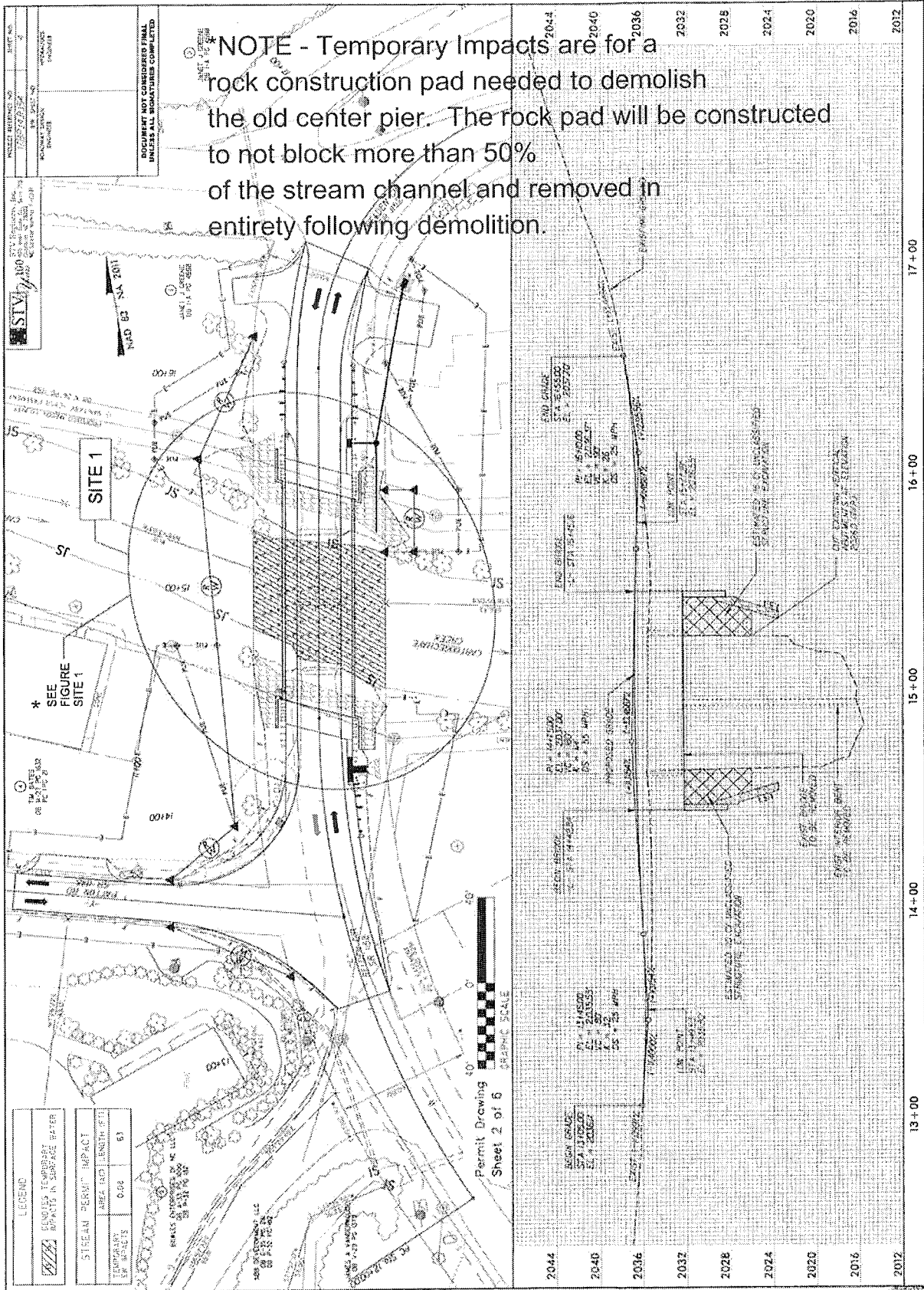

LEGEND	
	EMERGENCY TEMPORARY IMPACTS IN SURFACE WATER
	STREAM "PERMIT" IMPACT
	TEMPORARY AREA AND LENGTH (FT)
	IMPACTS 0:00 63

Permit Drawing
Sheet 2 of 6

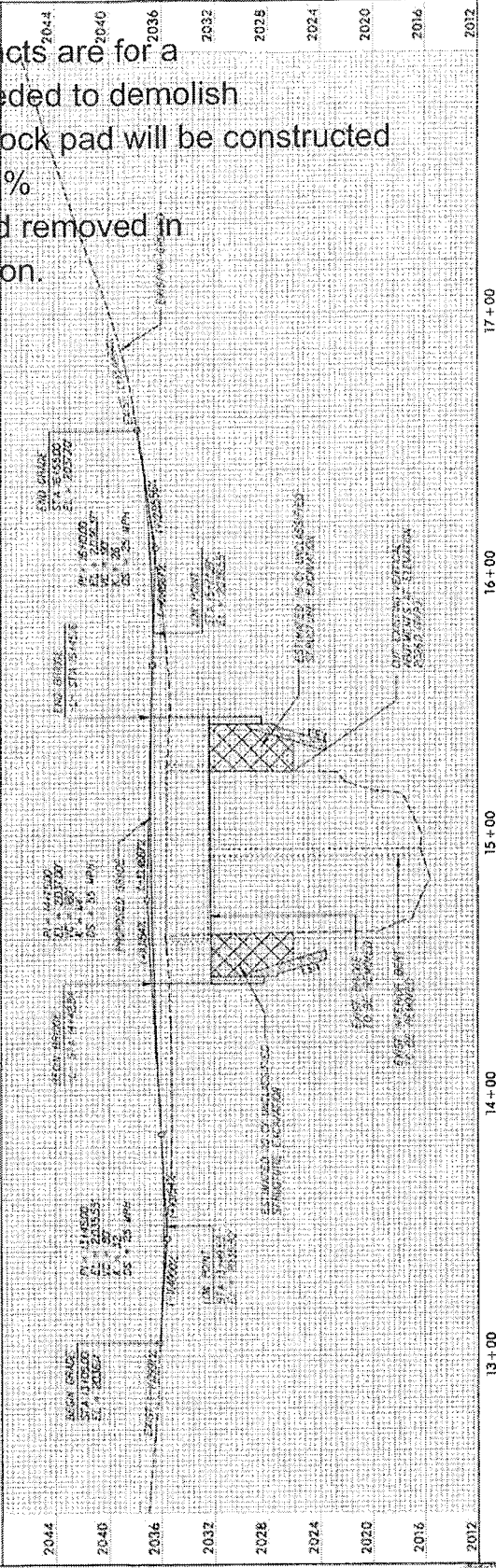

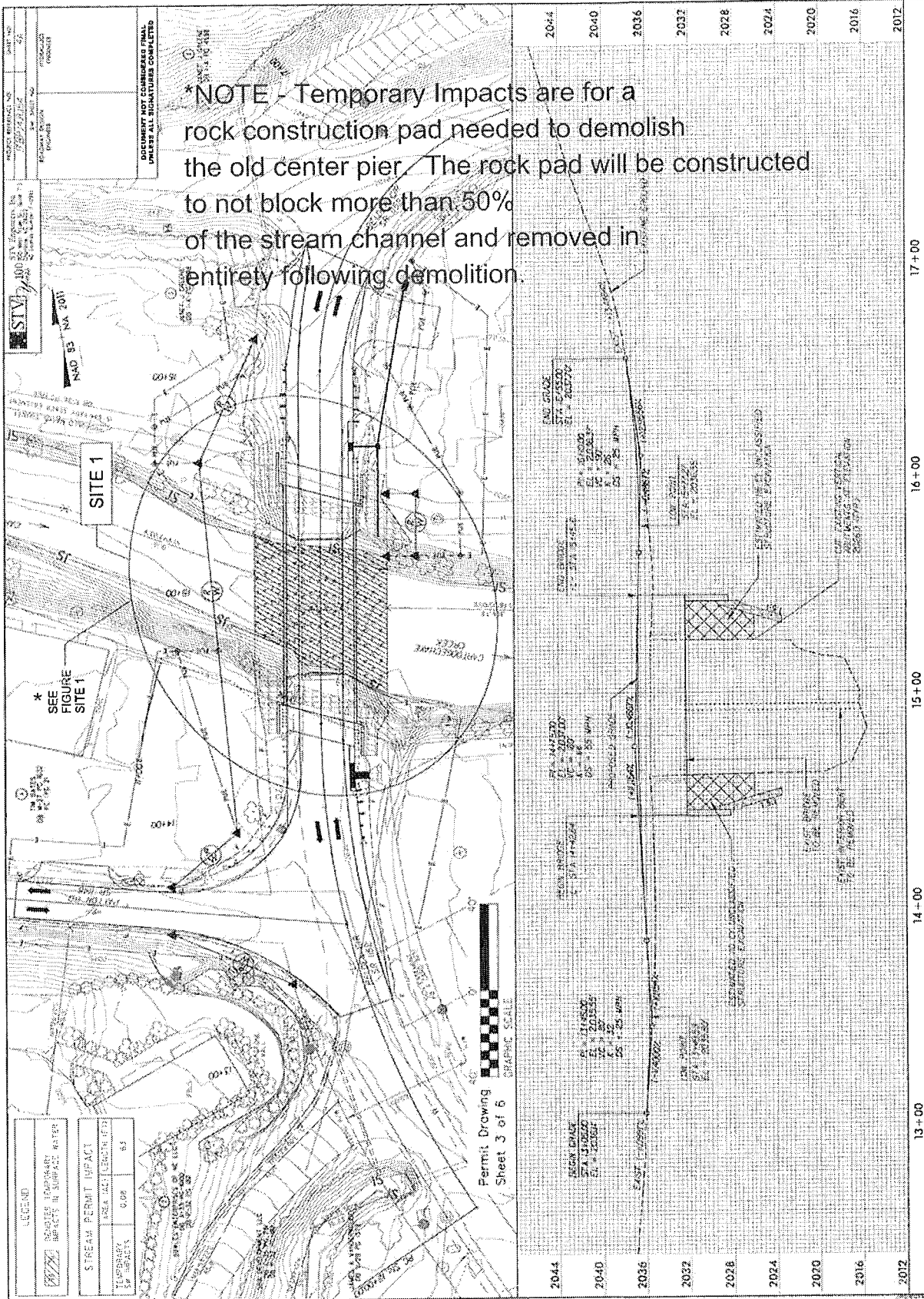

*NOTE - Temporary Impacts are for a rock construction pad needed to demolish the old center pier. The rock pad will be constructed to not block more than 50% of the stream channel and removed in entirety following demolition.

LEGEND	
[Symbol]	NEARBY TEMPORARY IMPACTS IN SURFACE WATER
[Symbol]	STREAM PERMIT IMPACT
[Symbol]	TEMPORARY IMPACTS
[Symbol]	AREA AFFECTED BY IMPACT
[Symbol]	IMPACT

Permit Drawing
Sheet 3 of 6

GRAPHIC SCALE

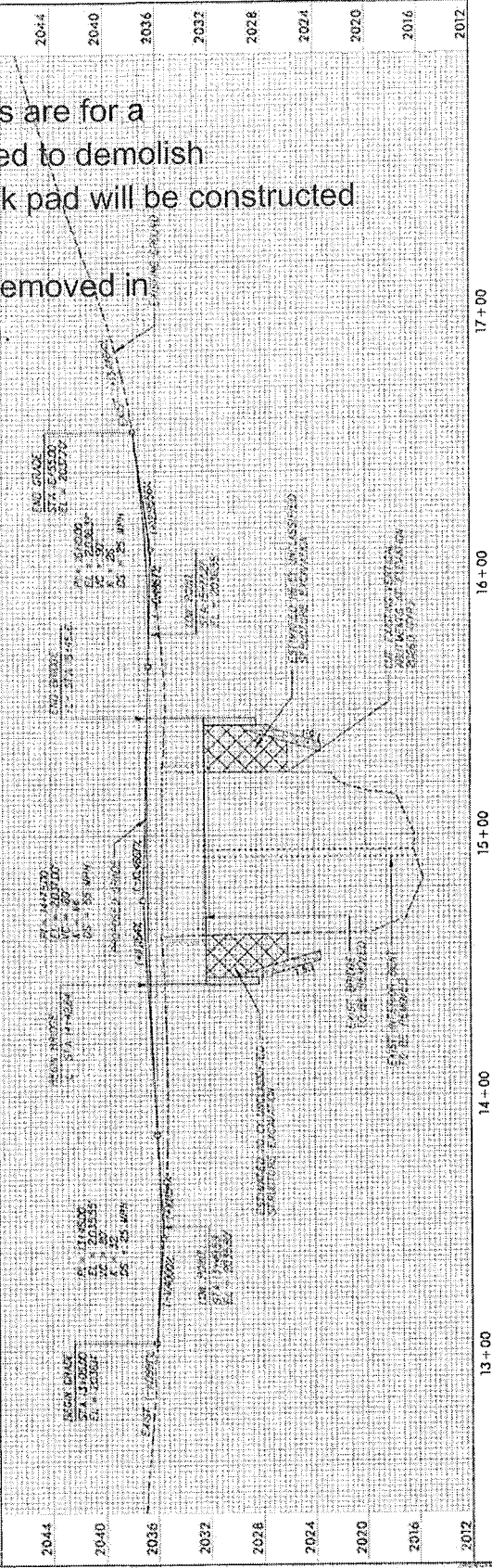

Year	Station
2012	13+00
2016	14+00
2020	15+00
2024	16+00
2028	17+00
2032	
2036	
2040	
2044	

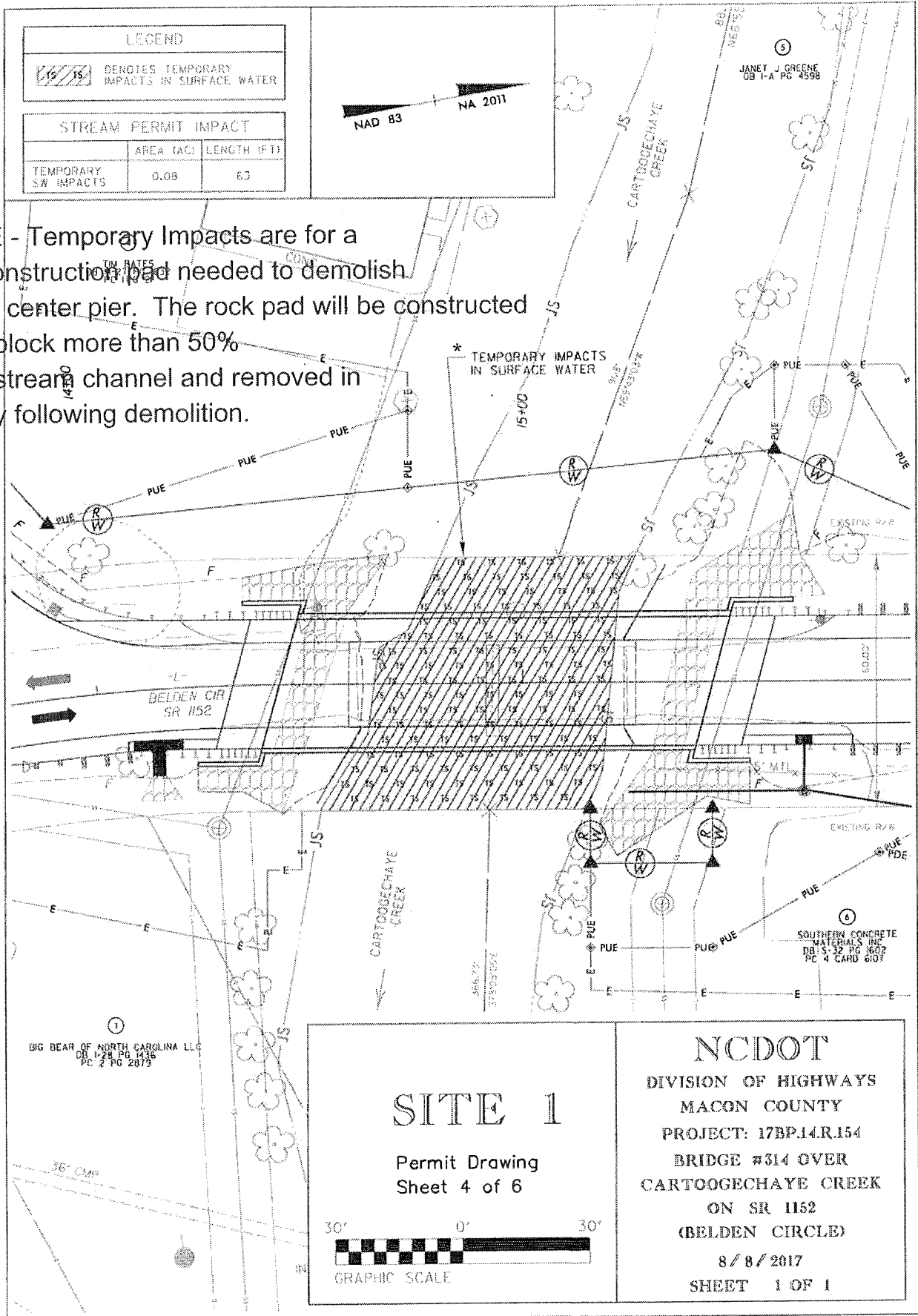

LEGEND		
	DENOTES TEMPORARY IMPACTS IN SURFACE WATER	
STREAM PERMIT IMPACT		
TEMPORARY SW IMPACTS	AREA (AC)	LENGTH (FT)
	0.08	63



*NOTE - Temporary Impacts are for a rock construction pad needed to demolish the old center pier. The rock pad will be constructed to not block more than 50% of the stream channel and removed in entirety following demolition.

SITE 1

Permit Drawing
Sheet 4 of 6

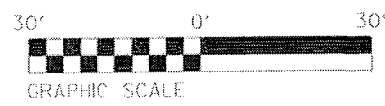

NCDOT
 DIVISION OF HIGHWAYS
 MACON COUNTY
 PROJECT: 17BP.14.R.154
 BRIDGE #314 OVER
 CARTOOGECHAYE CREEK
 ON SR 1152
 (BELDEN CIRCLE)
 8/8/2017
 SHEET 1 OF 1

PROPERTY OWNERS
NAMES AND ADDRESSES

PARCEL NO.	NAMES	ADDRESS
4	TIM BATES	BATES CROSSING FRANKLIN, NC 28734
5	JANET J GREENE	ROLLER MILL ROAD FRANKLIN, NC 28734

NCDOT
DIVISION OF HIGHWAYS
MACON COUNTY
PROJECT: 17BP.14.R.154
BRIDGE #314 OVER
CARTOOGECHAYE CREEK
ON SR 1152
(BELDEN CIR)

Permit Drawing
Sheet 5 of 6

PROJECT SPECIAL PROVISION

(10-18-95) (Rev. 3-21-17)

Z-1

PERMITS

The Contractor's attention is directed to the following permits, which have been issued to the Department of Transportation by the authority granting the permit.

<u>PERMIT</u>	<u>AUTHORITY GRANTING THE PERMIT</u>
Dredge and Fill and/or Work in Navigable Waters (404)	U. S. Army Corps of Engineers
Water Quality (401)	Division of Environmental Management, DEQ State of North Carolina
Trout Buffer Zone Waiver	Department of Energy, Mineral, and Land Resources, DEQ, State of North Carolina

The Contractor shall comply with all applicable permit conditions during construction of this project. Those conditions marked by * are the responsibility of the Department and the Contractor has no responsibility in accomplishing those conditions.

Agents of the permitting authority will periodically inspect the project for adherence to the permits.

The Contractor's attention is also directed to Articles 107-10 and 107-13 of the *2018 Standard Specifications* and the following:

Should the Contractor propose to utilize construction methods (such as temporary structures or fill in waters and/or wetlands for haul roads, work platforms, cofferdams, etc.) not specifically identified in the permit (individual, general, or nationwide) authorizing the project it shall be the Contractor's responsibility to coordinate with the Engineer to determine what, if any, additional permit action is required. The Contractor shall also be responsible for initiating the request for the authorization of such construction method by the permitting agency. The request shall be submitted through the Engineer. The Contractor shall not utilize the construction method until it is approved by the permitting agency. The request normally takes approximately 60 days to process; however, no extensions of time or additional compensation will be granted for delays resulting from the Contractor's request for approval of construction methods not specifically identified in the permit.

Where construction moratoriums are contained in a permit condition which restricts the Contractor's activities to certain times of the year, those moratoriums will apply only to the portions of the work taking place in the restricted waters, wetlands or buffer zones, provided that activities outside those areas is done in such a manner as to not affect the restricted waters, wetlands or buffer zones.

DocuSigned by:

 68A7405FFA5F48E...

P-58
U.S. ARMY CORPS OF ENGINEERS
WILMINGTON DISTRICT

Action Id. SAW-2016-01226 County: Macon County U.S.G.S. Quad: Franklin

GENERAL PERMIT (REGIONAL AND NATIONWIDE) VERIFICATION

Permittee: North Carolina Department of Transportation
Address: Mr. Dave McHenry
253 Webster Rd
Sylva NC, 28779

Size	<u>Approximately one mile</u>	Nearest Town	<u>Franklin</u>
Nearest Waterway	<u>Cartoogechaye Creek</u>	River Basin	<u>Upper Tennessee</u>
USGS HUC	<u>06010202</u>	Coordinates	Latitude: <u>35.1587586462431</u> Longitude: <u>-83.3917613812117</u>

Location description: The R5734A/US441 (Georgia Rd) improvement project begins just south of the intersection of US 441 with US 64, and extends approximately one mile south along US 441 in Franklin, Macon County, North Carolina.

Description of projects area and activity: This permit verification authorizes impacts resulting from the improvement of a one mile section of US 441 South. Specific impacts include the impact to 443 lf of stream channel due to a stream relocation, the temporary impact to 502 lf due to dewatering and construction and the permanent impact to 30 lf of stream channel due to bank stabilization.

Applicable Law: Section 404 (Clean Water Act, 33 USC 1344)
 Section 10 (Rivers and Harbors Act, 33 USC 403)

Authorization: Regional General Permit Number and/or Nationwide Permit Number: GP 198200031 NCDOT Bridges, Widening Projects.... (Authorized 2015)

Special Conditions

- 1) Per the Pre-construction notification dated 4/12/2018 and the US FWS subsequent 8/20/2018 letter, DOT will remove the trees required for bridge replacement during October 15 to April 15, avoiding impacts to potentially roosting bats.
- 2) In order to compensate for impacts associated with this permit, mitigation shall be provided in accordance with the provisions outlined on the most recent version of the attached Compensatory Mitigation Responsibility Transfer Form. The requirements of this form, including any special conditions listed on this form, are hereby incorporated as special conditions of this permit authorization.
- 3) The Permittee shall fully implement the enclosed Memorandum of Agreement between the Permittee, the North Carolina State Historic Preservation Officer and the Wilmington District US Army Corps of Engineers, which is incorporated herein by reference and attached to this permit.
- 4) As noted in the email from the NC Wildlife Resources Commission dated May 15, 2018, the permittee shall adhere to the long trout moratorium (no work within waters between October 15 and April 2015 of any given year) and will adhere to Design Standards in Sensitive Waters.

SEE ATTACHED RGP or NWP GENERAL, REGIONAL AND/OR SPECIAL CONDITIONS

Your work is authorized by the above referenced permit provided it is accomplished in strict accordance with the attached conditions and your submitted application dated April 12, 2018 and ensuing record. Any violation of the attached conditions or deviation from your submitted plans may subject the permittee to a stop work order, a restoration order, a Class I administrative penalty, and/or appropriate legal action.

This verification will remain valid until the expiration date identified below unless the nationwide and/or regional general permit authorization is modified, suspended or revoked. If, prior to the expiration date identified below, the nationwide and/or regional

P-59

general permit authorization is reissued and/or modified, this verification will remain valid until the expiration date identified below, provided it complies with all requirements of the modified nationwide permit. If the nationwide and/or regional general permit authorization expires or is suspended, revoked, or is modified, such that the activity would no longer comply with the terms and conditions of the nationwide permit, activities which have commenced (i.e., are under construction) or are under contract to commence in reliance upon the nationwide and/or regional general permit, will remain authorized provided the activity is completed within twelve months of the date of the nationwide and/or regional general permit's expiration, modification or revocation, unless discretionary authority has been exercised on a case-by-case basis to modify, suspend or revoke the authorization.

Activities subject to Section 404 (as indicated above) may also require an individual Section 401 Water Quality Certification. You should contact the NC Division of Water Resources (telephone 919-807-6300) to determine Section 401 requirements.

For activities occurring within the twenty coastal counties subject to regulation under the Coastal Area Management Act (CAMA), prior to beginning work you must contact the N.C. Division of Coastal Management in Morehead City, NC, at (252) 808-2808.

This Department of the Army verification does not relieve the permittee of the responsibility to obtain any other required Federal, State or local approvals/permits.

If there are any questions regarding this verification, any of the conditions of the Permit, or the Corps of Engineers regulatory program, please contact **Crystal Amschler at (828) 271-7980 X 4231 or Crystal.C.Amschler@usace.army.mil.**

Corps Regulatory Official: **AMSCHLER.CRYSTAL.C** Digitally signed by
AMSCHLER.CRYSTAL.CAMILLE.1238614178
DN: c=US, o=U.S. Government, ou=DoD, ou=PKI,
ou=USA, cn=AMSCHLER.CRYSTAL.CAMILLE.1238614178
Date: 2018.10.24 11:06:34 -04'00' **AMILLE.1238614178** Date: **October 24, 2018**

Expiration Date of Verification: **April 30, 2020**

Determination of Jurisdiction:

- 1. [X] There are waters, including wetlands, on the above described project area that may be subject to Section 404 of the Clean Water Act (CWA) (33 USC § 1344) and/or Section 10 of the Rivers and Harbors Act (RHA) (33 USC § 403). This preliminary determination is not an appealable action under the Regulatory Program Administrative Appeal Process (Reference 33 CFR Part 331). However, you may request an approved JD, which is an appealable action, by contacting the Corps district for further instruction. Please note, if work is authorized by either a general or nationwide permit, and you wish to request an appeal of an approved JD, the appeal must be received by the Corps and the appeal process concluded prior to the commencement of any work in waters of the United States and prior to any work that could alter the hydrology of waters of the United States.
2. [] There are Navigable Waters of the United States within the above described project area subject to the permit requirements of Section 10 of the Rivers and Harbors Act (RHA) (33 USC § 403) and Section 404 of the Clean Water Act (CWA) (33 USC § 1344). Unless there is a change in the law or our published regulations, this determination may be relied upon for a period not to exceed five years from the date of this notification.
3. [] There are waters, including wetlands, within the above described project area that are subject to the permit requirements of Section 404 of the Clean Water Act (CWA) (33 USC § 1344). Unless there is a change in the law or our published regulations, this determination may be relied upon for a period not to exceed five years from the date of this notification.
4. [] A jurisdiction determination was not completed with this request. Therefore, this is not an appealable action. However, you may request an approved JD, which is an appealable action, by contacting the Corps for further instruction.
5. [] The aquatic resources within the above described project area have been identified under a previous action. Please reference the approved jurisdictional determination issued . Action ID: SAW- .

A. Basis For Jurisdictional Determination: N/A. An Approved JD has not been completed.

B. Attention USDA Program Participants

This delineation/determination has been conducted to identify the limits of Corps' Clean Water Act jurisdiction for the particular site identified in this request. The delineation/determination may not be valid for the wetland conservation provisions of the Food Security Act of 1985. If you or your tenant are USDA Program participants, or anticipate participation in USDA programs, you should request a certified wetland determination from the local office of the Natural Resources Conservation Service, prior to starting work.

C. Appeals Information for Approved Jurisdiction Determinations (as indicated in A2 and A3 above).

If you object to this determination, you may request an administrative appeal under Corps regulations at 33 CFR Part 331. Enclosed you will find a Notification of Appeal Process (NAP) fact sheet and Request for Appeal (RFA) form. If you request to appeal this determination you must submit a completed RFA form to the following address:

US Army Corps of Engineers
South Atlantic Division
Attn: Jason Steele, Review Officer
60 Forsyth Street SW, Room 10M15
Atlanta, Georgia 30303-8801
Phone: (404) 562-5137

In order for an RFA to be accepted by the Corps, the Corps must determine that it is complete, that it meets the criteria for appeal under 33 CFR part 331.5, and that it has been received by the Division Office within 60 days of the date of the NAP. Should you decide to submit an RFA form, it must be received at the above address by _____.

It is not necessary to submit an RFA form to the Division Office if you do not object to the determination in this correspondence.

AMSCHLER.CRYSTAL.

Digitally signed by
AMSCHLER.CRYSTAL.CAMILLE.1238614178
DN: c=US, o=U.S. Government, ou=DoD, ou=PKI, ou=USA,
cn=AMSCHLER.CRYSTAL.CAMILLE.1238614178
Date: 2018.10.24.11:07:23 -04'00'

Corps Regulatory Official: CAMILLE.1238614178

Crystal Amschler

Date of JD: October 24, 2018

The Wilmington District is committed to providing the highest level of support to the public. To help us ensure we continue to do so, please complete our Customer Satisfaction Survey, located online at http://corpsmapu.usace.army.mil/cm_apex/?p=136:4:0.

P-61

Action ID Number: SAW-2016-01226

County: Macon County

Permittee: North Carolina Department of Transportation, Mr. Dave McHenry

Project Name: NCDOT/R-5734A/US 23/US 441/Div 14

Date Verification Issued: October 24, 2018

Project Manager: Crystal Amschler

Upon completion of the activity authorized by this permit and any mitigation required by the permit, sign this certification and return it to the following address:

US ARMY CORPS OF ENGINEERS
WILMINGTON DISTRICT
Attn: Crystal Amschler, Project Manager
Asheville Regulatory Field Office
151 Patton Avenue, Room 208
Asheville, North Carolina 28801

Please note that your permitted activity is subject to a compliance inspection by a U. S. Army Corps of Engineers representative. Failure to comply with any terms or conditions of this authorization may result in the Corps suspending, modifying or revoking the authorization and/or issuing a Class I administrative penalty, or initiating other appropriate legal action.

I hereby certify that the work authorized by the above referenced permit has been completed in accordance with the terms and condition of the said permit, and required mitigation was completed in accordance with the permit conditions.

Signature of Permittee

Date

**NOTIFICATION OF ADMINISTRATIVE APPEAL OPTIONS AND PROCESS AND
REQUEST FOR APPEAL**

Applicant: North Carolina Department of Transportation, Mr. Dave McHenry	File Number: SAW-2016-01226	Date: October 24, 2018
---	------------------------------------	-------------------------------

Attached is:	See Section below
<input type="checkbox"/> INITIAL PROFFERED PERMIT (Standard Permit or Letter of permission)	A
<input type="checkbox"/> PROFFERED PERMIT (Standard Permit or Letter of permission)	B
<input type="checkbox"/> PERMIT DENIAL	C
<input type="checkbox"/> APPROVED JURISDICTIONAL DETERMINATION	D
<input checked="" type="checkbox"/> PRELIMINARY JURISDICTIONAL DETERMINATION	E

SECTION I - The following identifies your rights and options regarding an administrative appeal of the above decision. Additional information may be found at <http://www.usace.army.mil/Missions/CivilWorks/RegulatoryProgramandPermits.aspx> or Corps regulations at 33 CFR Part 331.

A: INITIAL PROFFERED PERMIT: You may accept or object to the permit.

- **ACCEPT:** If you received a Standard Permit, you may sign the permit document and return it to the district engineer for final authorization. If you received a Letter of Permission (LOP), you may accept the LOP and your work is authorized. Your signature on the Standard Permit or acceptance of the LOP means that you accept the permit in its entirety, and waive all rights to appeal the permit, including its terms and conditions, and approved jurisdictional determinations associated with the permit.
- **OBJECT:** If you object to the permit (Standard or LOP) because of certain terms and conditions therein, you may request that the permit be modified accordingly. You must complete Section II of this form and return the form to the district engineer. Your objections must be received by the district engineer within 60 days of the date of this notice, or you will forfeit your right to appeal the permit in the future. Upon receipt of your letter, the district engineer will evaluate your objections and may: (a) modify the permit to address all of your concerns, (b) modify the permit to address some of your objections, or (c) not modify the permit having determined that the permit should be issued as previously written. After evaluating your objections, the district engineer will send you a proffered permit for your reconsideration, as indicated in Section B below.

B: PROFFERED PERMIT: You may accept or appeal the permit

- **ACCEPT:** If you received a Standard Permit, you may sign the permit document and return it to the district engineer for final authorization. If you received a Letter of Permission (LOP), you may accept the LOP and your work is authorized. Your signature on the Standard Permit or acceptance of the LOP means that you accept the permit in its entirety, and waive all rights to appeal the permit, including its terms and conditions, and approved jurisdictional determinations associated with the permit.
- **APPEAL:** If you choose to decline the proffered permit (Standard or LOP) because of certain terms and conditions therein, you may appeal the declined permit under the Corps of Engineers Administrative Appeal Process by completing Section II of this form and sending the form to the division engineer. This form must be received by the division engineer within 60 days of the date of this notice.

C: PERMIT DENIAL: You may appeal the denial of a permit under the Corps of Engineers Administrative Appeal Process by completing Section II of this form and sending the form to the division engineer. This form must be received by the division engineer within 60 days of the date of this notice.

D: APPROVED JURISDICTIONAL DETERMINATION: You may accept or appeal the approved JD or provide new information.

- **ACCEPT:** You do not need to notify the Corps to accept an approved JD. Failure to notify the Corps within 60 days of the date of this notice means that you accept the approved JD in its entirety, and waive all rights to appeal the approved JD.
- **APPEAL:** If you disagree with the approved JD, you may appeal the approved JD under the Corps of Engineers Administrative Appeal Process by completing Section II of this form and sending the form to the division engineer. This form must be received by the division engineer within 60 days of the date of this notice.

P-63

E: PRELIMINARY JURISDICTIONAL DETERMINATION: You do not need to respond to the Corps regarding the preliminary JD. The Preliminary JD is not appealable. If you wish, you may request an approved JD (which may be appealed), by contacting the Corps district for further instruction. Also you may provide new information for further consideration by the Corps to reevaluate the JD.

SECTION II - REQUEST FOR APPEAL or OBJECTIONS TO AN INITIAL PROFFERED PERMIT

REASONS FOR APPEAL OR OBJECTIONS: (Describe your reasons for appealing the decision or your objections to an initial proffered permit in clear concise statements. You may attach additional information to this form to clarify where your reasons or objections are addressed in the administrative record.)

ADDITIONAL INFORMATION: The appeal is limited to a review of the administrative record, the Corps memorandum for the record of the appeal conference or meeting, and any supplemental information that the review officer has determined is needed to clarify the administrative record. Neither the appellant nor the Corps may add new information or analyses to the record. However, you may provide additional information to clarify the location of information that is already in the administrative record.

POINT OF CONTACT FOR QUESTIONS OR INFORMATION:

If you have questions regarding this decision and/or the appeal process you may contact:

**District Engineer, Wilmington Regulatory Division,
Attn: Crystal Amschler
69 Darlington Avenue
Wilmington, North Carolina 28403**

If you only have questions regarding the appeal process you may also contact:

**Mr. Jason Steele, Administrative Appeal Review Officer
CESAD-PDO
U.S. Army Corps of Engineers, South Atlantic Division
60 Forsyth Street, Room 10M15
Atlanta, Georgia 30303-8801
Phone: (404) 562-5137**

RIGHT OF ENTRY: Your signature below grants the right of entry to Corps of Engineers personnel, and any government consultants, to conduct investigations of the project site during the course of the appeal process. You will be provided a 15 day notice of any site investigation, and will have the opportunity to participate in all site investigations.

Date:

Telephone number:

Signature of appellant or agent.

For appeals on Initial Proffered Permits send this form to:

District Engineer, Wilmington Regulatory Division, Attn: Crystal Amschler, 69 Darlington Avenue, Wilmington, North Carolina 28403

For Permit denials, Proffered Permits and approved Jurisdictional Determinations send this form to:

**Division Engineer, Commander, U.S. Army Engineer Division, South Atlantic, Attn: Mr. Jason Steele, Administrative Appeal Officer, CESAD-PDO, 60 Forsyth Street, Room 10M15, Atlanta, Georgia 30303-8801
Phone: (404) 562-5137**



United States Department of the Interior

FISH AND WILDLIFE SERVICE
 Asheville Field Office
 160 Zillicoa Street Suite #B
 Asheville, North Carolina 28801



August 20th, 2018

Ms. Crystal Ameshler, NCDOT Regulatory Project Manager
 U.S. Army Corps of Engineers
 151 Patton Avenue, Room 208
 Asheville, NC 28801-2714

Subject: 18-378, Highway Improvements, R5734A US 23/441, Macon County

Dear Ms. Amschler,

On July 25th, 2018, we received your email requesting section 7 concurrence on effects the subject high improvement may have on the federally threatened Indiana Bat (*Myotis sodalists*). The following comments are provided in accordance with section 7 of the Endangered Species Act of 1973, as amended (16 U.S.C. 1531-1543) (Act).

Based on the size of the culvert that will be extended for this project (42 feet long, five by six feet wide), we agree that it does not provide suitable bat roosting habitat. We suggest inspecting culverts for bat presence starting at a minimum of five feet tall and 200 feet long. Additionally, you have committed to remove the approximately 50 trees required for highway improvements during October 15th to April 15th, avoiding impacts to potentially roosting bats. Accordingly, we concur with your determination that the proposed bridge replacement project may affect, but is not likely to adversely affect, the Indiana Bat.

As outlined in the Biological Opinion completed on the 4(d) rule for the federally threatened Northern long-eared bat (NLEB, *Myotis septentrionalis*) on 1/5/16, this activity is now excepted from take prohibitions for Northern long-eared bat, based on the project location. Project activities in the action area: (1) would not affect a known hibernation site; (2) are not located within ¼ mile of a known hibernation site, or; (3) are not located within a 150' radius of a known maternity (tree) site. The project location is more than four miles away from any known NLEB location.

Therefore, we believe the requirements under Section 7(c) of the Endangered Species Act (ESA) of 1973, as amended (16 U.S.C. 1531 - 1543), are fulfilled. Obligations under Section 7 of the ESA must be reconsidered if: (1) new information reveals impacts of this identified action that may affect listed species or critical habitat in a manner not previously considered, (2) this action is subsequently modified in a manner that was not considered in this review, or (3) a new species is listed or critical habitat is determined that may be affected by the identified action.

If you have questions about these comments please contact Ms. Claire Ellwanger of our staff at 828/258-3939, Ext. 235. In any future correspondence concerning these projects, please reference our Log Number 18-378.

Sincerely,

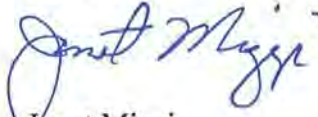
A handwritten signature in blue ink that reads "Janet Mizzi". The signature is written in a cursive style with a large initial "J" and a long, sweeping underline.

Janet Mizzi
Field Supervisor

P-66

DEPARTMENT OF THE ARMY
Wilmington District, Corps of Engineers
69 Darlington Avenue
Wilmington, North Carolina 28403-1343
April 30, 2015

Regional General Permit No. 198200031
Name of Permittee: North Carolina Department of Transportation
Effective Date: April 30, 2015
Expiration Date: April 30, 2020

DEPARTMENT OF THE ARMY REGIONAL GENERAL PERMIT

A regional general permit (RGP) to perform work in or affecting navigable waters of the United States and waters of the United States, upon recommendation of the Chief of Engineers, pursuant to Section 10 of the Rivers and Harbors Act of March 3, 1899 (33 U.S.C. 403), and Section 404 of the Clean Water Act (33 U.S.C. 1344), is hereby modified and re-issued by authority of the Secretary of the Army by the

District Commander
U.S. Army Engineer District, Wilmington
Corps of Engineers
69 Darlington Avenue
Wilmington, North Carolina 28403-1343

TO AUTHORIZE THE DISCHARGE OF DREDGED OR FILL MATERIAL IN WATERS OF THE UNITED STATES (U.S.), INCLUDING WETLANDS, ASSOCIATED WITH MAINTENANCE, REPAIR, AND CONSTRUCTION PROJECTS CONDUCTED BY THE VARIOUS DIVISIONS OF THE NORTH CAROLINA DEPARTMENT OF TRANSPORTATION (NCDOT) INCLUDING THE NCDOT DIVISION OF HIGHWAYS, RAIL, BICYCLE/PEDESTRIAN, ECT.

Activities authorized are:

- a. Construction, maintenance, and repair of bridges, to include work on the approaches, where permanent impacts resulting in a loss of waters of the U.S. will be less than or equal to 500 linear feet (lf) of stream and/or one (1) acre of wetland/non-tidal open water for each single and complete linear project*.
- b. Best-fit widening projects that have undergone interagency review and completed the current interagency Merger Process, which merges the requirements of the National Environmental Policy Act (NEPA) with those found within Section 404 of the Clean Water Act (CWA).

While there is no impact threshold for these widening projects, the Corps has the discretion to require an individual permit if it determines that the proposed impacts will have more than a minimal impact on the aquatic environment or on other environmental factors, or if the project would normally require an Environmental Impact Statement (EIS) under current Federal Highway Administration (FHWA) guidelines. Best-fit projects may include a small amount of new location roadway for components such as interchanges or intersections, provided the new location portion has been concurred upon by the merger team.

c. Minor widening projects, such as paving and/or widening secondary roads, or interchange improvements, when permanent impacts which result in a loss of waters of the U.S. from installation and/or extension of culverts and/or pipes will be less than or equal to 500 lf of stream and/or one (1) acre of wetland/non-tidal open water for each single and complete linear project*.

d. Stream relocation(s) associated with projects identified in a-c above. Stream relocation lengths are to be evaluated independently and are not included within each respective maximum limit threshold for the authorized actions stated above.

***Single and complete linear project:** A linear project is a project constructed for the purpose of getting people, goods, or services from a point of origin to a terminal point, which often involves multiple crossings of one or more waterbodies at separate and distant locations. The term “single and complete project” is defined as that portion of the total linear project proposed or accomplished by one owner/developer or partnership or other association of owners/developers that includes all crossings of a single water of the U.S. (i.e., a single waterbody) at a specific location. For linear projects crossing a single or multiple waterbodies several times at separate and distant locations, each crossing is considered a single and complete project for purposes of this RGP. However, individual channels in a braided stream or river, or individual arms of a large, irregularly shaped wetland or lake, etc., are not separate waterbodies, and crossings of such features cannot be considered separately.

Generally, off-site detours are preferred to avoid and minimize impacts to the human and natural environment. However, if an off-site detour is considered impracticable, then an on-site detour may be considered as a necessary component of the actions described above. Impacts from the detour may be considered temporary and may not require compensatory mitigation if the impacted area is restored to its pre-project condition after construction is complete. If the construction of a detour (on-site or off-site) includes standard undercutting methods, removal of all material and backfilling with suitable material is required.

1. Special Conditions.

a. The applicant must submit a pre-construction notification (PCN) with specified attachments to the District Engineer and receive written verification from the Corps that the proposed work complies with this RGP prior to commencing any activity authorized by this RGP.

b. If the project will not impact a designated “Area of Environmental Concern” (AEC) in the twenty (20) counties of North Carolina covered by the North Carolina Coastal Area Management Act (CAMA), then a consistency submission is not required. If the project will impact a designated AEC and meets the definition of “development”, then the applicant must

obtain the required CAMA permit. Development activities may not commence until a copy of the approved CAMA permit is furnished to the appropriate Wilmington District Regulatory Field Office (Wilmington Field Office – 69 Darlington Avenue, Wilmington, NC 28403 or Washington Field Office – 2407 West 5th Street, Washington, NC 27889).

The twenty (20) CAMA counties in North Carolina include Beaufort, Bertie, Brunswick, Camden, Carteret, Chowan, Craven, Currituck, Dare, Gates, Hertford, Hyde, New Hanover, Onslow, Pamlico, Pasquotank, Pender, Perquimans, Tyrrell, and Washington.

c. Discharges into Waters of the U.S. designated by either the North Carolina Division of Marine Fisheries (NCDMF) or the North Carolina Wildlife Resources Commission (NCWRC) as anadromous fish spawning areas are prohibited during the period between February 1 and June 30, without prior written approval from NCDMF, NCWRC, National Marine Fisheries Service (NMFS), and the Corps. Discharges into waters of the U.S. designated by NCDMF as primary nursery areas and discharges into waters of the U.S. designated by NCWRC as primary nursery areas in inland waters shall be coordinated with NCDCM (per existing agreement with NCDMF) and NCWRC prior to being authorized by this RGP. Coordination with NCDCM and NCWRC may result in a required construction moratorium during periods of significant biological productivity or critical life stages.

The applicant should contact:

NC Division of Marine Fisheries
3441 Arendell Street
Morehead City, NC 28557
Telephone 252-726-7021
or 800-682-2632

North Carolina Wildlife Resources Commission
Habitat Conservation Program Manager
1721 Mail Service Center
Raleigh, NC 27699-1721
Telephone (919) 733-7638

d. This permit does not authorize the use of culverts in areas designated as anadromous fish spawning areas by the NCDMF or the NCWRC.

e. Waters of the U.S. designated as sturgeon spawning areas are excluded during the period between February 1 and June 30, without prior written approval from NMFS.

f. If the project is located within the twenty (20) counties of North Carolina designated as coastal counties by CAMA, then all pipe and culvert inverts will be buried at least one foot below normal bed elevation when they are placed within the Public Trust AEC and/or the Estuarine Waters AEC as designated by CAMA. If the project is not located within the twenty (20) counties of North Carolina designated as coastal counties by CAMA, then culvert inverts will be buried at least one foot below the bed of the stream for culverts greater than 48 inches in diameter. Culverts 48 inches in diameter or less shall be buried or placed on the stream bed as practicable and appropriate to maintain aquatic passage, and every effort shall be made to maintain the existing channel slope. The potential for destabilization of the channel and head cutting upstream should be considered in the placement of the culvert. A waiver from the depth specifications in this condition may be requested in writing. The waiver will only be issued if it can be demonstrated that the impacts of complying with this condition would result in more adverse impacts to the aquatic environment. Culverts placed in wetlands do not have to be buried.

g. No work shall be authorized by this RGP within the twenty coastal counties, as defined by the NCDCM, without prior consultation with NOAA Fisheries. For each activity reviewed by the Corps where it is determined that the activity may affect Essential Fish Habitat (EFH) for federally managed species, an EFH Assessment shall be prepared by the applicant and forwarded to the Corps and NOAA Fisheries for review and comment prior to authorization of work.

h. Discharges of dredged or fill material into waters of the U.S., including wetlands, must be minimized or avoided to the maximum extent practicable.

i. No activity may result in substantial permanent disruption of the movement of those species of aquatic life indigenous to the waterbody, including those species that normally migrate through the area. The dimension, pattern, and profile of the stream above and below a pipe or culvert should not be modified by widening the stream channel or by reducing the depth of the stream in connection with the construction activity. It is acceptable to use rock vanes at culvert outlets to ensure, enhance, or maintain aquatic passage. Pre-formed scour holes are acceptable when designed for velocity reduction. The width, height, and gradient of a proposed opening should be such as to pass the average historical low flow and spring flow without adversely altering flow velocity. Spring flow should be determined from gauge data, if available. In the absence of such data, bankfull flow can be used as a comparable level. Where adjacent floodplain is available, flows exceeding bank-full should be accommodated by installing culverts at the floodplain elevation, if practicable. If multiple culverts are used, the construction of floodplain benches and/or sills to maintain base flow is required, if practicable.

j. Upon completion of any work authorized by this RGP, all temporary fills (to include culverts, etc.) will be completely removed from waters of the U.S. and the areas will be restored to preconstruction conditions, to include pre-project elevations and contours, restoring natural hydrology and stream corridors, and reestablishing native vegetation/riparian corridors. This work will be completed within 60 days of completion of project construction. If this timeframe occurs while a required moratorium of this permit is in effect, the temporary fill shall be removed in its entirety within 60 days of the moratorium end date. If vegetation cannot be planted due to the time of the year, all disturbed areas will be seeded with a native mix appropriate for the impacted area, and vegetation will be planted in the fall. A native seed mix may contain non-invasive small grain annuals (e.g. millet and rye grain) to ensure adequate cover while native vegetation becomes established. The PCN must include a restoration plan showing how all temporary fills and structures will be removed and how the area will be restored to pre-project conditions.

k. All activities authorized by this RGP shall, to the extent practicable, be conducted "in the dry", with barriers installed between work areas and aquatic habitat to protect that habitat from sediment, concrete, and other pollutants. Where concrete is utilized, measures will be taken to prevent live or fresh concrete, including bags of uncured concrete, from coming into contact with waters of the U.S. until the concrete has cured/hardened. All water in the work area that has been in contact with concrete shall only be returned to waters of the U.S. when it no longer poses a threat to aquatic organisms (concrete is set and cured).

l. In cases where new alignment approaches are to be constructed and the existing approach fill in waters of the U.S. is to be abandoned and no longer maintained as a roadway, the

abandoned fill shall be removed and the area will be restored to preexisting wetland/stream conditions and elevations, to include restoring natural hydrology and stream corridors, and reestablishing native vegetation/riparian corridors, to the extent practicable. This activity may qualify as compensatory mitigation credit for the project and will be assessed on a case-by-case basis in accordance with Special Conditions “q” and “r” below. A restoration plan detailing this activity will be required with the submittal of the PCN.

m. To the maximum extent practicable, the pre-construction course, condition, capacity, and location of open waters must be maintained for each activity, including stream channelization and storm water management activities, except as provided below. The activity must be constructed to withstand expected high flows. The activity must not restrict or impede the passage of normal or high flows. The activity may alter the pre-construction course, condition, capacity, and location of open waters if it benefits the aquatic environment (e.g., stream restoration or relocation activities).

n. The project must be implemented and/or conducted so that all reasonable and practicable measures to ensure that equipment, structures, fill pads, and work associated with the project do not adversely affect upstream and/or downstream reaches. Adverse effects include, but are not limited to, channel instability, flooding, and/or shoreline/streambank erosion. During construction, the permittee shall routinely monitor for these effects, cease all work if/when detected, take initial corrective measures to correct actively eroding areas, and notify the Corps immediately. Permanent corrective measures may require additional authorization from the Corps.

o. All PCNs will describe sedimentation and erosion control structures and measures proposed for placement in waters of the U.S. To the extent practicable, structures and measures should be depicted on maps, surveys or drawings showing location and impacts to jurisdictional wetlands and streams. In addition, appropriate soil and erosion control measures must be established and maintained during construction. All fills, temporary and permanent, must be adequately stabilized at the earliest practicable date to prevent erosion of fill material into adjacent waters or wetlands.

p. Before discharging dredged or fill material into waters of the U.S. in the twenty-five (25) mountain counties of North Carolina, the applicant will submit a PCN to the NCWRC and the Corps concurrently. The PCN shall summarize alternatives to conducting work in mountain trout waters considered during the planning process, detail why alternatives were or were not selected, and contain a compensatory mitigation plan for all unavoidable adverse impacts to mountain trout waters. For proposals where a bridge is replaced with a culvert, the PCN must also include details of any on-site evaluations that were conducted to determine that installation of a culvert will not adversely affect passage of fish or other aquatic biota at the project site. This information must include factors such as the proposed slope of the culvert and determinations of how the slope will be expected to allow or impede passage, the necessity of baffles and/or sills to ensure passage, design considerations to ensure that expected baseflow will be maintained for passage and that post-construction velocities will not prevent passage, site conditions that will or will not allow proper burial of the culvert, existing structures (e.g., perched culverts, waterfalls, etc.) and/or stream patterns up and downstream of the culvert site that could affect passage and bank stability, and any other considerations regarding passage. The level of detail for this information should be based on site conditions (i.e., culverts on a slope over 3% will most likely

require more information than culverts on a slope that is less than 1%, etc.). Also, in order to evaluate potential impacts, describe bedforms that will be impacted by the proposed culvert – e.g., pools, glides, riffles, etc. The NCWRC will respond both to the proponent and directly to the Corps.

The twenty-five (25) designated trout counties of North Carolina include Alleghany, Caldwell, Watauga, Ashe, Mitchell, Wilkes, Avery, Burke, Stokes, Surry, Buncombe, Henderson, Polk, Cherokee, Jackson, Rutherford, Clay, Macon, Swain, Graham, Madison, Transylvania, Haywood, McDowell, and Yancey.

The applicant may contact NCWRC at:

North Carolina Wildlife Resources
Commission
Ms. Marla Chambers
Western NCDOT Permit Coordinator
206 Charter Street
Albemarle, NC 28001
Office: 704-982-9181

q. Compensatory mitigation will be required for permanent impacts resulting in a loss of waters of the U.S., including wetlands, from culverts/pipes and associated fill. Mitigation will also be required for stream relocation projects. The applicant will attach a proposed mitigation plan to the PCN. Mitigation proposals will be in accordance with currently approved Wilmington District and/or Corps-wide mitigation regulations and guidance. The Corps Project Manager will make the final determination concerning the appropriate amount and type of mitigation.

r. Stream relocation(s) associated with projects may be authorized under this RGP. As stated above, mitigation will be required for all relocation projects. If the stream relocation is conducted in accordance with the requirements stated below in 1-5, the relocated segment of stream may* be considered toward reducing the amount of compensatory mitigation required. A relocation plan must be submitted with the PCN that addresses all factors required within the current Wilmington District, Corps of Engineers Stream Mitigation Guidelines, which can include, but may not be limited to:

(1) The relocated stream has pattern, profile, and dimension based on natural channel design. If natural channel design construction is not possible due to site constraints, the relocated stream must have pattern, profile, and dimension similar to, or better than, the existing stream. Note that site constraints do not include those situations where NCDOT chooses not to acquire additional adjacent property that is available for purchase.

(2) The new stream meets the current buffer requirements as stated in current District stream mitigation guidance. If the required buffer widths cannot be obtained, a project-by-project decision will be completed to determine if additional compensatory mitigation is required.

(3) The new location allows the relocated stream to remain stable (e.g., in a

valley vs. on a slope, no bends that will impact stability, etc.).

(4) There is no loss of channel for any reason (e.g., old channel is 200' and new channel is 150' = 50' channel loss; part of the new channel is put in a culvert; the new channel (sides and bottom) is hardened with concrete, rip rap, etc.).

(5) The Corps will determine if monitoring and reporting will be required for a specific project and the parameters of any required monitoring and reporting. If monitoring is required, a monitoring plan must be included with the PCN and meet current requirements.

All relocation plans must clearly depict both the existing channel and the proposed (relocated) channel.

* Conducting stream relocation(s) in accordance with 1-5 above may not fully compensate for the impact and may require additional compensatory mitigation. The Corps Project Manager will determine if the proposed amount of mitigation is adequate on a project-by-project basis.

If stream relocation cannot be conducted in accordance with 1-5 above, mitigation at a 2:1 ratio will typically be required unless: (1) the applicant provides a Stream Quality Assessment Worksheet or NCSAM documentation (when available) that supports a different mitigation ratio; (2) the Corps Project Manager determines that the relocated stream, while not in full compliance with 1-5 above, warrants partial mitigation, or; (3) the Corps determines that the existing stream is an excellent quality stream, in which case a 3:1 mitigation ratio may be required. The Corps Project Manager will make the final determination concerning the appropriate amount and type of mitigation.

If the Corps determines that the proposed stream relocation is of such a magnitude that it cannot be authorized by this RGP, an Individual Permit will be required.

s. The applicant shall sign and return the compliance certificate that is attached to the RGP verification letter.

t. In the event that any Federal agency maintains an objection or any required State authorization is outstanding, no notice to proceed will be given until objections are resolved and State authorizations are issued.

u. The Corps may place additional special conditions, limitations, or restrictions on any verification of the use of RGP 31 on a project-by-project basis.

2. General Conditions.

a. Except as authorized by this RGP or any Corps approved modification to this RGP, no excavation, fill or mechanized land-clearing activities shall take place within waters or wetlands, at any time in the construction or maintenance of this project. This permit does not authorize temporary placement or double handling of excavated or fill material within waters or wetlands outside the permitted area. This prohibition applies to all borrow and fill activities connected with this project.

b. Authorization under this RGP does not obviate the need to obtain other federal, state, or local authorizations.

c. All work authorized by this RGP must comply with the terms and conditions of the applicable CWA Section 401 Water Quality Certification for this RGP issued by the NCDWR.

d. The permittee shall employ all sedimentation and erosion control measures necessary to prevent an increase in sedimentation or turbidity within waters and wetlands outside the permit area. This shall include, but is not limited to, the immediate installation of silt fencing or similar appropriate devices around all areas subject to soil disturbance or the movement of earthen fill, and the immediate stabilization of all disturbed areas. Additionally, the project must remain in full compliance with all aspects of the Sedimentation Pollution Control Act of 1973 (North Carolina General Statutes Chapter 113A Article 4).

e. The activities authorized by this RGP must not interfere with the public's right to free navigation on all navigable waters of the U.S. No attempt will be made by the permittee to prevent the full and free use by the public of all navigable waters at or adjacent to the authorized work for a reason other than safety.

f. The permittee understands and agrees that, if future operations by the U.S. require the removal, relocation, or other alteration, of the structure or work herein authorized, or if, in the opinion of the Secretary of the Army or his authorized representative, said structure or work shall cause unreasonable obstruction to the free navigation of the navigable waters, the permittee will be required, upon due notice from the Corps of Engineers, to remove, relocate, or alter the structural work or obstructions caused thereby, without expense to the U.S. No claim shall be made against the U.S. on account of any such removal or alteration.

g. The permittee, upon receipt of a notice of revocation of this permit or upon its expiration before completion of the work will, without expense to the U.S. and in such time and manner as the Secretary of the Army or his authorized representative may direct, restore the affected water of the U.S. to its former conditions.

h. The permittee will allow the Wilmington District Engineer or his representative to inspect the authorized activity at any time deemed necessary to assure that the activity is being performed or maintained in strict accordance with the Special and General Conditions of this permit.

i. This RGP does not grant any property rights or exclusive privileges.

j. This permit does not authorize any injury to the property or rights of others.

k. This RGP does not authorize the interference with any existing or proposed federal project.

l. In issuing this permit, the Federal Government does not assume any liability for the following:

(1) Damages to the permitted project or uses thereof as a result of other permitted

or unpermitted activities or from natural causes.

(2) Damages to the permitted project or uses thereof as a result of current or future activities undertaken by or on behalf of the U.S. in the public interest.

(3) Damages to persons, property, or to other permitted or unpermitted activities or structures caused by the activity authorized by this permit.

(4) Design or construction deficiencies associated with the permitted work.

(5) Damage claims associated with any future modification, suspension, or revocation of this permit.

m. Authorization provided by this RGP may be modified, suspended or revoked in whole or in part if the Wilmington District Engineer, acting for the Secretary of the Army, determines that such action is in the best public interest. The term of this RGP shall be five (5) years unless subject to modification, suspension or revocation. Any modification, suspension or revocation of this authorization will not be the basis for any claim for damages against the U.S. Government.

n. This RGP does not authorize any activity, which the District Engineer determines, after any necessary investigations, will adversely affect:

(1) Rivers named in Section 3 of the Wild and Scenic Rivers Act (15 U.S.C. 1273), those proposed for inclusion as provided by Sections 4 and 5 of the Act, and wild, scenic and recreational rivers established by state and local entities.

(2) Sites included in or determined eligible for listing in the National Registry of Natural Landmarks.

(3) NOAA designated marine sanctuaries, National Estuarine Research Reserves, and coral reefs.

(4) Submerged Aquatic Vegetation (SAV) as defined by the N.C. Division of Marine Fisheries at 15A NCAC 03I .0101(4)(i)).

o. Endangered Species.

(1) No activity is authorized under this RGP which is likely to directly or indirectly jeopardize the continued existence of a threatened or endangered species or a species proposed for such designation, as identified under the Federal Endangered Species Act (ESA), or which will directly or indirectly destroy or adversely modify the critical habitat of such species. No activity is authorized under this RGP which "may affect" a listed species or critical habitat, unless Section 7 consultation addressing the effects of the proposed activity has been completed.

(2) Federal agencies should follow their own procedures for complying with the requirements of the ESA. Federal permittees (and when FHWA is the lead federal agency) must provide the district engineer with the appropriate documentation to demonstrate compliance with

those requirements. The district engineer will review the documentation and determine whether it is sufficient to address ESA compliance for the RGP activity, or whether additional ESA consultation is necessary.

(3) Non-federal permittees must submit a PCN to the district engineer if any listed species or designated critical habitat might be affected or is in the vicinity of the project, or if the project is located in designated critical habitat, and shall not begin work on the activity until notified by the district engineer that the requirements of the ESA have been satisfied and that the activity is authorized. For activities that might affect federally-listed endangered or threatened species or designated critical habitat, the PCN must include the name(s) of the endangered or threatened species that might be affected by the proposed work or that utilize the designated critical habitat that might be affected by the proposed work. The district engineer will determine whether the proposed activity “may affect” or will have “no effect” to listed species and designated critical habitat and will notify the non-federal applicant of the Corps’ determination within 45 days of receipt of a complete PCN notification. In cases where the non-federal applicant has identified listed species or critical habitat that might be affected or is in the vicinity of the project, and has so notified the Corps, the applicant shall not begin work until the Corps has provided notification that the proposed activities will have “no effect” on listed species or critical habitat, or until Section 7 consultation has been completed. If the non-federal applicant has not heard back from the Corps within 45 days, the applicant must still wait for notification from the Corps.

(4) As a result of formal or informal consultation with the U.S. Fish and Wildlife Service (USFWS) or NMFS, the district engineer may add species-specific endangered species conditions to the RGP.

(5) Authorization of an activity by a RGP does not authorize the “take” of a threatened or endangered species as defined under the ESA. In the absence of separate authorization (e.g., an ESA Section 10 Permit, a Biological Opinion with “incidental take” provisions, etc.) from the USFWS or the NMFS, the ESA prohibits any person subject to the jurisdiction of the U.S. to take a listed species, where “take” means to harass, harm, pursue, hunt, shoot, wound, kill, trap, capture, or collect, or to attempt to engage in any such conduct. The word “harm” in the definition of “take” means an act which actually kills or injures wildlife. Such an act may include significant habitat modification or degradation where it actually kills or injures wildlife by significantly impairing essential behavioral patterns, including breeding, feeding or sheltering.

(6) Information on the location of threatened and endangered species and their critical habitat can be obtained directly from the offices of the USFWS and NMFS or their world wide web pages at <http://www.fws.gov/> or <http://www.fws.gov/ipac> and <http://www.noaa.gov/fisheries.html> respectively.

p. The permittee is responsible for obtaining any “take” permits required under the USFWS’s regulations governing compliance with the Migratory Bird Treaty Act or the Bald and Golden Eagle Protection Act. The permittee should contact the appropriate local office of the USFWS to determine if such “take” permits are required for a particular activity.

q. For proposed activities the sixteen counties listed below, applicants must provide a

P-76

copy of the PCN to the USFWS, 160 Zillicoa Street, Asheville, North Carolina 28801. This PCN must be sent concurrently to the USFWS and the Corps Project Manager for that specific county.

Counties with tributaries that drain to designated critical habitat that require notification to the Asheville USFWS: Avery, Cherokee, Forsyth, Graham, Haywood, Henderson, Jackson, Macon Mecklenburg, Mitchell, Stokes, Surry, Swain, Transylvania, Union and Yancey.

Applicants may contact the appropriate USFWS office listed below or the US Army Corps of Engineers:

US Fish and Wildlife Service
Asheville Field Office
160 Zillicoa Street
Asheville, NC 28801
Telephone: (828) 258-3939

Asheville USFWS Office counties: All counties west of and including Anson, Stanly, Davidson, Forsyth and Stokes Counties.

US Fish and Wildlife Service
Raleigh Field Office
Post Office Box 33726
Raleigh, NC 27636-3726
Telephone: (919) 856-4520

Raleigh USFWS Office counties: all counties east of and including Richmond, Montgomery, Randolph, Guilford, and Rockingham Counties.

r. Permittees are advised that development activities in or near a floodway may be subject to the National Flood Insurance Program that prohibits any development, including fill, within a floodway that results in any increase in base flood elevations. This RGP does not authorize any activity prohibited by the National Flood Insurance Program.

s. The permittee must make every reasonable effort to perform the work authorized herein in a manner so as to minimize any adverse impact on fish, wildlife and natural environmental values.

t. All activities authorized by this RGP that involve the use of riprap material for bank stabilization, the following measures shall be applied:

(1) Filter cloth must be placed underneath the riprap as an additional requirement of its use in North Carolina waters.

(2) The placement of riprap shall be limited to the areas depicted on submitted work plan drawings and not be placed in a manner that prevents or impedes fish passage.

(3) The riprap material shall be clean and free from loose dirt or any pollutant

P-77

except in trace quantities that will not have an adverse environmental effect.

(4) It shall be of a size sufficient to prevent its movement from the authorized alignment by natural forces under normal conditions.

(5) The riprap material shall consist of clean rock or masonry material such as, but not limited to, granite, marl, or broken concrete.

(6) A waiver from the specifications in this general condition may be requested in writing. The waiver will only be issued if it can be demonstrated that the impacts of complying with this condition will result in greater adverse impacts to the aquatic environment.

u. The permittee must install and maintain, at his expense, any signal lights and signals prescribed by the U.S. Coast Guard, through regulations or otherwise, on authorized facilities. For further information, the permittee should contact the U.S. Coast Guard Marine Safety Office at (910) 772-2191.

v. The permittee must maintain any structure or work authorized by this permit in good condition and in conformance with the terms and conditions of this permit. The Permittee is not relieved of this requirement if the Permittee abandons the structure or work. Transfer in fee simple of the work authorized by this permit will automatically transfer this permit to the property's new owner, with all of the rights and responsibilities enumerated herein. The permittee must inform any subsequent owner of all activities undertaken under the authority of this permit and provide the subsequent owner with a copy of the terms and conditions of this permit.

w. At his sole discretion, any time during the processing cycle, the Wilmington District Engineer may determine that this RGP will not be applicable to a specific proposal. In such case, the procedures for processing an individual permit in accordance with 33 CFR 325 will be available.

x. The activity must comply with applicable FEMA approved state or local floodplain management requirements.

y. All fill material placed in waters or wetlands shall be generated from an upland source and will be clean and free of any pollutants except in trace quantities. Metal products, organic materials (including debris from land clearing activities), or unsightly debris will not be used.

z. All excavated material will be disposed of in approved upland disposal areas.

aa. Historic Properties.

(1) In cases where the district engineer determines that the activity may affect properties listed, or eligible for listing, in the National Register of Historic Places (NRHP), the activity is not authorized, until the requirements of Section 106 of the National Historic Preservation Act (NHPA) have been satisfied.

(2) Federal permittees (or when FHWA is the lead federal agency) should follow their own procedures for complying with the requirements of Section 106 of the NHPA. Federal permittees must provide the district engineer with the appropriate documentation to demonstrate compliance with those requirements. The district engineer will review the documentation and determine whether it is sufficient to address Section 106 compliance for this RGP activity, or whether additional Section 106 consultation is necessary.

(3) Non-federal permittees must submit a PCN to the district engineer if the authorized activity may have the potential to cause effects to any historic properties listed on, determined to be eligible for listing on, or potentially eligible for listing on the NRHP, including previously unidentified properties. For such activities, the PCN must state which historic properties may be affected by the proposed work or include a vicinity map indicating the location of the historic properties or the potential for the presence of historic properties. Assistance regarding information on the location of or potential for the presence of historic resources can be sought from the State Historic Preservation Officer (SHPO) or Tribal Historic Preservation Officer (THPO), as appropriate, and the NRHP (see 33 CFR 330.4(g)). When reviewing PCNs, district engineers will comply with the current procedures for addressing the requirements of Section 106 of the NHPA. The district engineer shall make a reasonable and good faith effort to carry out appropriate identification efforts, which may include background research, consultation, oral history interviews, sample field investigation, and field survey. Based on the information submitted and these efforts, the district engineer shall determine whether the proposed activity has the potential to cause an effect on the historic properties. Where the non-federal applicant has identified historic properties on which the activity may have the potential to cause effects and so notified the Corps, the non-federal applicant shall not begin the activity until notified by the district engineer either that the activity has no potential to cause effects or that consultation under Section 106 of the NHPA has been completed.

(4) The district engineer will notify the prospective permittee within 45 days of receipt of a complete PCN whether NHPA Section 106 consultation is required. Section 106 consultation is not required when the Corps determines that the activity does not have the potential to cause effects on historic properties (see 36 CFR §800.3(a)). If NHPA Section 106 consultation is required and will occur, the district engineer will notify the non-federal applicant that he or she cannot begin work until Section 106 consultation is completed. If the non-federal applicant has not heard back from the Corps within 45 days, the applicant must still wait for notification from the Corps.

(5) Prospective permittees should be aware that Section 110k of the NHPA (16 U.S.C. 470h-2(k)) prevents the Corps from granting a permit or other assistance to an applicant who, with intent to avoid the requirements of Section 106 of the NHPA, has intentionally significantly adversely affected a historic property to which the permit will relate, or having legal power to prevent it, allowed such significant adverse effect to occur, unless the Corps, after consultation with the Advisory Council on Historic Preservation (ACHP), determines that circumstances justify granting such assistance despite the adverse effect created or permitted by the applicant. If circumstances justify granting the assistance, the Corps is required to notify the ACHP and provide documentation specifying the circumstances, the degree of damage to the integrity of any historic properties affected, and proposed mitigation. This documentation must include any views obtained from the applicant, SHPO/THPO, appropriate Indian tribes if the

undertaking occurs on or affects historic properties on tribal lands or affects properties of interest to those tribes, and other parties known to have a legitimate interest in the impacts to the permitted activity on historic properties.

bb. If you discover any previously unknown historic or archeological remains while accomplishing the activity authorized by this permit, you must immediately notify this office of what you have found. We will initiate the Federal and state coordination required to determine if the remains warrant a recovery effort or if the site is eligible for listing in the NRHP.

cc. There will be no unreasonable interference with navigation or the right of the public to riparian access by the existence or use of activities authorized by this RGP.

dd. Heavy equipment working in wetlands or mudflats must be placed on mats, or other measures must be taken to minimize soil disturbance.

ee. This RGP will not be applicable to proposed construction when the Wilmington District Engineer determines that the proposed activity will significantly affect the quality of the human environment and determines that an EIS must be prepared.

ff. Activities which have commenced (i.e. are under construction) or are under contract to commence in reliance upon this general permit will remain authorized provided the activity is completed within twelve months of the date of the general permit's expiration, modification, or revocation. Activities completed under the authorization of this general permit which were in effect at the time the activity was completed continue to be authorized by the general permit.

BY AUTHORITY OF THE SECRETARY OF THE ARMY:



Kevin P. Landers Sr.
Colonel, U. S. Army
District Commander



ROY COOPER
Governor

MICHAEL S. REGAN
Secretary

LINDA CULPEPPER
Interim Director

April 17, 2018
Macon County
NCDWR Project No. 20180523
Road Improvements on US 441S
TIP Project No. R-5734A

APPROVAL of 401 WATER QUALITY CERTIFICATION with ADDITIONAL CONDITIONS

Mr. David G. McHenry, Environmental Officer
NCDOT, Division 14
253 Webster Road
Sylva, North Carolina 28779

Dear Mr. McHenry:

You have our approval, in accordance with the conditions listed below, for the following impacts for the purpose of roadway improvements in Macon County:

Stream Impacts in the Little Tennessee River Basin

Site	Permanent Fill in Perennial Stream (linear ft)	Temporary Fill in Perennial Stream (linear ft)	Total Stream Impact (linear ft)
S1	443		443
S2		458	458
S3	10		10
S4	20		60
S5		44	20
TOTAL	473	502	991

Total Stream Impact for Project: 991 linear feet.

The project shall be constructed in accordance with your application received April 12, 2018. After reviewing your application, we have decided that these impacts are covered by General Water Quality Certification Number 4135. This certification corresponds to the **Regional General** Permit 31 issued by the Corps of Engineers. In addition, you should acquire any other federal, state or local permits before you proceed with your project including (but not limited to) Sediment and Erosion Control, Non-Discharge and Water Supply Watershed regulations. This approval will expire with the accompanying 404 permit.

This approval is valid solely for the purpose and design described in your application (unless modified below). Should your project change, you must notify the NCDWR and submit a new application. If the property is sold, the new owner must be given a copy of this Certification and approval letter, and is thereby responsible for complying with all the conditions. If total wetland fills for this project (now or in the future) exceed one acre, or of total

P-81

impacts to streams (now or in the future) exceed 150 linear feet, compensatory mitigation may be required as described in 15A NCAC 2H .0506 (h) (6) and (7) For this approval to remain valid, you must adhere to the conditions listed in the attached certification(s) and any additional conditions listed below.

Condition(s) of Certification:

Project Specific Conditions

1. The permittee will need to adhere to all appropriate in-water work moratoria (including the use of pile driving or vibration techniques) prescribed by the **NC Wildlife Resources Commission**. No in-water work is permitted between October 15 and April 15 of any year, without prior approval from the NC Division of Water Resources and the NC Wildlife Resources Commission.

In-stream work and land disturbance within the 25-foot buffer zone are prohibited during the trout-spawning season of October 15 through April 15 to protect the egg and fry stages of trout.
2. The NCDOT Division Environmental Officer or Environmental Assistant will conduct a pre-construction meeting with all appropriate staff to ensure that the project supervisor and essential staff understand the potential issues with stream and pipe alignment at the permitted site. NCDWR staff shall be invited to the pre-construction meeting. [15A NCAC 02H.0506(b)(2) and (b)(3)]
3. Compensatory mitigation for 443 linear feet of impact to streams is required. We understand that you have chosen to perform compensatory mitigation for impacts to streams through the North Carolina Division of Mitigation Service (DMS) (formerly NCEEP), and that the DMS has agreed to implement the mitigation for the project. The DMS has indicated in a letter dated March 13, 2018 that they will assume responsibility for satisfying the federal Clean Water Act compensatory mitigation requirements for the above-referenced project, in accordance with the DMS Mitigation Banking Instrument signed July 28, 2010.

General Conditions

1. Unless otherwise approved in this certification, placement of culverts and other structures in open waters and streams shall be placed below the elevation of the streambed by one foot for all culverts with a diameter greater than 48 inches, and 20 percent of the culvert diameter for culverts having a diameter less than 48 inches, to allow low flow passage of water and aquatic life. Design and placement of culverts and other structures including temporary erosion control measures shall not be conducted in a manner that may result in dis-equilibrium of wetlands or streambeds or banks, adjacent to or upstream and downstream of the above structures. The applicant is required to provide evidence that the equilibrium is being maintained if requested in writing by NCDWR. If this condition is unable to be met due to bedrock or other limiting features encountered during construction, please contact NCDWR for guidance on how to proceed and to determine whether or not a permit modification will be required. [15A NCAC 02H.0506(b)(2)]
2. If concrete is used during construction, a dry work area shall be maintained to prevent direct contact between curing concrete and stream water. Water that inadvertently contacts uncured concrete shall not be discharged to surface waters due to the potential for elevated pH and possible aquatic life and fish kills. [15A NCAC 02B.0200]
3. During the construction of the project, no staging of equipment of any kind is permitted in waters of the U.S., or protected riparian buffers. [15A NCAC 02H.0506(b)(2)]
4. The dimension, pattern and profile of the stream above and below the crossing shall not be modified. Disturbed floodplains and streams shall be restored to natural geomorphic conditions. [15A NCAC 02H.0506(b)(2)]
5. The use of rip-rap above the Normal High Water Mark shall be minimized. Any rip-rap placed for stream stabilization shall be placed in stream channels in such a manner that it does not impede aquatic life passage. [15A NCAC 02H.0506(b)(2)]

P-82

- * 6. The Permittee shall ensure that the final design drawings adhere to the permit and to the permit drawings submitted for approval. [15A NCAC 02H .0507(c) and 15A NCAC 02H .0506 (b)(2) and (c)(2)]
7. All work in or adjacent to stream waters shall be conducted in a dry work area. Approved BMP measures from the most current version of NCDOT Construction and Maintenance Activities manual such as sandbags, rock berms, cofferdams and other diversion structures shall be used to prevent excavation in flowing water. [15A NCAC 02H.0506(b)(3) and (c)(3)]
8. Heavy equipment shall be operated from the banks rather than in the stream channel in order to minimize sedimentation and reduce the introduction of other pollutants into the stream. [15A NCAC 02H.0506(b)(3)]
9. All mechanized equipment operated near surface waters must be regularly inspected and maintained to prevent contamination of stream waters from fuels, lubricants, hydraulic fluids, or other toxic materials. [15A NCAC 02H.0506(b)(3)]
10. No rock, sand or other materials shall be dredged from the stream channel except where authorized by this certification. [15A NCAC 02H.0506(b)(3)]
11. Discharging hydroseed mixtures and washing out hydroseeders and other equipment in or adjacent to surface waters is prohibited. [15A NCAC 02H.0506(b)(3)]
12. The permittee and its authorized agents shall conduct its activities in a manner consistent with State water quality standards (including any requirements resulting from compliance with §303(d) of the Clean Water Act) and any other appropriate requirements of State and Federal law. If the NCDWR determines that such standards or laws are not being met (including the failure to sustain a designated or achieved use) or that State or federal law is being violated, or that further conditions are necessary to assure compliance, the NCDWR may reevaluate and modify this certification. [15A NCAC 02B.0200]
13. All fill slopes located in jurisdictional wetlands shall be placed at slopes no flatter than 3:1, unless otherwise authorized by this certification. [15A NCAC 02H.0506(b)(2)]
14. A copy of this Water Quality Certification shall be maintained on the construction site at all times. In addition, the Water Quality Certification and all subsequent modifications, if any, shall be maintained with the Division Engineer and the on-site project manager. [15A NCAC 02H .0507(c) and 15A NCAC 02H .0506 (b)(2) and (c)(2)]
15. The outside buffer, wetland or water boundary located within the construction corridor approved by this authorization shall be clearly marked by highly visible fencing prior to any land disturbing activities. Impacts to areas within the fencing are prohibited unless otherwise authorized by this certification. [15A NCAC 02H.0501 and .0502]
16. The issuance of this certification does not exempt the Permittee from complying with any and all statutes, rules, regulations, or ordinances that may be imposed by other government agencies (i.e. local, state, and federal) having jurisdiction, including but not limited to applicable buffer rules, stormwater management rules, soil erosion and sedimentation control requirements, etc.
17. The Permittee shall report any violations of this certification to the Division of Water Resources within 24 hours of discovery. [15A NCAC 02B.0506(b)(2)]
- * 18. Upon completion of the project (including any impacts at associated borrow or waste sites), the NCDOT Division Engineer shall complete and return the enclosed "Certification of Completion Form" to notify the NCDWR when all work included in the 401 Certification has been completed. [15A NCAC 02H.0502(f)]
19. There shall be no excavation from, or waste disposal into, jurisdictional wetlands or waters associated with this permit without appropriate modification. Should waste or borrow sites, or access roads to waste or borrow sites, be located in wetlands or streams, compensatory mitigation will be required since that is a direct impact from road construction activities.[15A NCAC 02H.0506(b)(3) and (c)(3)]

P-83

20. Erosion and sediment control practices must be in full compliance with all specifications governing the proper design, installation and operation and maintenance of such Best Management Practices in order to protect surface waters standards [15A NCAC 02H.0506(b)(3) and (c)(3)]:
- The erosion and sediment control measures for the project must be designed, installed, operated, and maintained in accordance with the most recent version of the *North Carolina Sediment and Erosion Control Planning and Design Manual*.
 - The design, installation, operation, and maintenance of the sediment and erosion control measures must be such that they equal, or exceed, the requirements specified in the most recent version of the *North Carolina Sediment and Erosion Control Manual*. The devices shall be maintained on all construction sites, borrow sites, and waste pile (spoil) projects, including contractor-owned or leased borrow pits associated with the project.
 - For borrow pit sites, the erosion and sediment control measures must be designed, installed, operated, and maintained in accordance with the most recent version of the *North Carolina Surface Mining Manual*.
 - The reclamation measures and implementation must comply with the reclamation in accordance with the requirements of the Sedimentation Pollution Control Act.
21. Sediment and erosion control measures shall not be placed in wetlands or waters unless otherwise approved by this Certification. [15A NCAC 02H.0506(b)(3) and (c)(3)]

If you wish to contest any statement in the attached Certification you must file a petition for an administrative hearing. You may obtain the petition form from the office of Administrative hearings. You must file the petition with the office of Administrative Hearings within sixty (60) days of receipt of this notice. A petition is considered filed when it is received in the office of Administrative Hearings during normal office hours. The Office of Administrative Hearings accepts filings Monday through Friday between the hours of 8:00am and 5:00pm, except for official state holidays. The original and one (1) copy of the petition must be filed with the Office of Administrative Hearings.

The petition may be faxed-provided the original and one copy of the document is received by the Office of Administrative Hearings within five (5) business days following the faxed transmission. The mailing address for the Office of Administrative Hearings is:

Office of Administrative Hearings
6714 Mail Service Center
Raleigh, NC 27699-6714
Telephone: (919) 431-3000, Facsimile: (919) 431-3100

A copy of the petition must also be served on DEQ as follows:

Mr. Bill F. Lane, General Counsel
Department of Environmental Quality
1601 Mail Service Center

This letter completes the review of the Division of Water Resources under Section 401 of the Clean Water Act. If you have any questions, please contact Kevin Barnett at (828)230-8470 or kevin.barnett@ncdenr.gov.

Sincerely,



Linda Culpepper, Interim Director
Division of Water Resources

Electronic copy only distribution:

Lori Beckwith, US Army Corps of Engineers, Asheville Field Office
Marla Chambers, NC Wildlife Resources Commission
File Copy

STATE OF NORTH CAROLINA
DEPARTMENT OF ENVIRONMENTAL QUALITY
DIVISION OF WATER RESOURCES

WATER QUALITY GENERAL CERTIFICATION NO. 4135

GENERAL CERTIFICATION FOR PROJECTS ELIGIBLE FOR US ARMY CORPS OF ENGINEERS

- **NATIONWIDE PERMIT NUMBER 14 (LINEAR TRANSPORTATION PROJECTS), AND**
- **REGIONAL GENERAL PERMIT 198200031 (NCDOT BRIDGES, WIDENING PROJECTS, INTERCHANGE IMPROVEMENTS)**

Water Quality Certification Number 4135 is issued in conformity with the requirements of Section 401, Public Laws 92-500 and 95-217 of the United States and subject to the North Carolina Regulations in 15A NCAC 02H .0500 and 15A NCAC 02B .0200 for the discharge of fill material to surface waters and wetland areas as described in 33 CFR 330 Appendix A (B) (14) of the US Army Corps of Engineers regulations and Regional General Permit 198200031.

The State of North Carolina certifies that the specified category of activity will not violate applicable portions of Sections 301, 302, 303, 306 and 307 of the Public Laws 92-500 and 95-217 if conducted in accordance with the conditions hereinafter set forth.

Effective date: December 1, 2017

Signed this day: December 1, 2017

By

A handwritten signature in black ink, appearing to read 'Linda Culpepper', is written over a solid horizontal line.

for Linda Culpepper
Interim Director

P-85
GC4135

Activities meeting any one (1) of the following thresholds or circumstances require written approval for a 401 Water Quality Certification from the Division of Water Resources (DWR):

- a) If any of the conditions of this Certification (listed below) cannot be met; or
- b) Any temporary or permanent impacts to wetlands, open waters and/or streams, except for construction of a driveway to a single family residential lot that is determined to not be part of a larger common plan of development, as long as the driveway involves a travel lane of less than 25 feet and total stream impacts of less than 60 feet, including any topographic/slope stabilization or in-stream stabilization needed for the crossing; or
- c) Any stream relocation or stream restoration; or
- d) Any high-density project, as defined in 15A NCAC 02H .1003(2)(a) and by the density thresholds specified in 15A NCAC 02H .1017, which:
 - i. Disturbs one acre or more of land (including a project that disturbs less than one acre of land that is part of a larger common plan of development or sale); and
 - ii. Has permanent wetland, stream or open water impacts; and
 - iii. Is proposing new built-upon area; and
 - iv. Does not have a stormwater management plan reviewed and approved under a state stormwater program¹ or a state-approved local government stormwater program².

Projects that have vested rights, exemptions, or grandfathering from state or locally-implemented stormwater programs and projects that satisfy state or locally-implemented stormwater programs through use of community in-lieu programs **require written approval**; or

- e) Any permanent impacts to waters, or to wetlands adjacent to waters, designated as: ORW (including SAV), HQW (including PNA), SA, WS-I, WS-II, or North Carolina or National Wild and Scenic River.
- f) Any permanent impacts to waters, or to wetlands adjacent to waters, designated as Trout except for driveway projects that are below threshold (b) above provided that:
 - i. The impacts are not adjacent to any existing structures
 - ii. All conditions of this General Certification can be met, including adherence to any moratoriums as stated in Condition #10; and
 - iii. A *Notification of Work in Trout Watersheds Form* is submitted to the Division at least 60 days prior to commencement of work; or
- g) Any permanent impacts to coastal wetlands [15A NCAC 07H .0205], or Unique Wetlands (UWL); or
- h) Any impact associated with a Notice of Violation or an enforcement action for violation(s) of NC Wetland Rules (15A NCAC 02H .0500), NC Isolated Wetland Rules (15A NCAC 02H .1300), NC Surface Water or Wetland Standards (15A NCAC 02B .0200), or State Regulated Riparian Buffer Rules (15A NCAC 02B .0200); or

¹ e.g. Coastal Counties, HQW, ORW, or state-implemented Phase II NPDES

² e.g. Delegated Phase II NPDES, Water Supply Watershed, Nutrient-Sensitive Waters, or Universal Stormwater Management Program

**P-86
GC4135**

- * i) Any impacts to subject water bodies and/or state regulated riparian buffers along subject water bodies in the Neuse, Tar-Pamlico, or Catawba River Basins or in the Randleman Lake, Jordan Lake or Goose Creek Watersheds (or any other basin or watershed with State Regulated Riparian Area Protection Rules [Buffer Rules] in effect at the time of application) *unless*:
 - i. The activities are listed as “EXEMPT” from these rules; or
 - ii. A Buffer Authorization Certificate is issued by the NC Division of Coastal Management (DCM); or
 - iii. A Buffer Authorization Certificate or a Minor Variance is issued by a delegated or designated local government implementing a state riparian buffer program pursuant to 143-215.23

Activities included in this General Certification that do not meet one of the thresholds listed above do not require written approval.

I. ACTIVITY SPECIFIC CONDITIONS:

- * 1. If this Water Quality Certification is used to access residential, commercial or industrial building sites, then all parcels owned by the applicant that are part of the single and complete project authorized by this Certification must be buildable without additional impacts to streams or wetlands. If required in writing by DWR, the applicant shall provide evidence that the parcels are buildable without requiring additional impacts to wetlands, waters, or state regulated riparian buffers. [15A NCAC 02H .0506(b)(4) and (c)(4)]
- 2. For road and driveway construction purposes, this Certification shall only be utilized from natural high ground to natural high ground. [15A NCAC 02H .0506(b)(2) and (c)(2)]
- * 3. Deed notifications or similar mechanisms shall be placed on all lots with retained jurisdictional wetlands, waters, and state regulated riparian buffers within the project boundaries in order to assure compliance with NC Wetland Rules (15A NCAC 02H .0500), NC Isolated Wetland Rules (15A NCAC 02H .1300), and/or State Regulated Riparian Buffer Rules (15A NCAC 02B .0200). These mechanisms shall be put in place at the time of recording of the property or individual parcels, whichever is appropriate. [15A NCAC 02H .0506(b)(4) and (c)(4)]
- 4. For the North Carolina Department of Transportation, compliance with the NCDOT’s individual NPDES permit NCS000250 shall serve to satisfy this condition. All other high-density projects that trigger threshold item (d) above shall comply with one of the following requirements: [15A NCAC 02H .0506(b)(5) and (c)(5)]

P-87
GC4135

- a. Provide a completed Stormwater Management Plan (SMP) for review and approval, including all appropriate stormwater control measure (SCM) supplemental forms and associated items, that complies with the high-density development requirements of 15A NCAC 02H .1003. Stormwater management shall be provided throughout the entire project area in accordance with 15A NCAC 02H .1003. For the purposes of 15A NCAC 02H .1003(2)(a), density thresholds shall be determined in accordance with 15A NCAC 02H .1017.
- b. Provide documentation (including calculations, photos, etc.) that the project will not cause degradation of downstream surface waters. Documentation shall include a detailed analysis of the hydrological impacts from stormwater runoff when considering the volume and velocity of stormwater runoff from the project built upon area and the size and existing condition of the receiving stream(s).

Exceptions to this condition require application to and written approval from DWR.

II. GENERAL CONDITIONS:

- *1. When written authorization is required, the plans and specifications for the project are incorporated into the authorization by reference and are an enforceable part of the Certification. Any modifications to the project require notification to DWR and may require an application submittal to DWR with the appropriate fee. [15A NCAC 02H .0501 and .0502]
2. No waste, spoil, solids, or fill of any kind shall occur in wetlands or waters beyond the footprint of the impacts (including temporary impacts) as authorized in the written approval from DWR; or beyond the thresholds established for use of this Certification without written authorization. [15A NCAC 02H .0501 and .0502]

No removal of vegetation or other impacts of any kind shall occur to state regulated riparian buffers beyond the footprint of impacts approved in a Buffer Authorization or Variance or as listed as an exempt activity in the applicable riparian buffer rules. [15A NCAC 02B .0200]

- *3. In accordance with 15A NCAC 02H .0506(h) and Session Law 2017-10, compensatory mitigation may be required for losses of greater than 300 linear feet of perennial streams and/or greater than one (1) acre of wetlands. Impacts associated with the removal of a dam shall not require mitigation when the removal complies with the requirements of Part 3 of Article 21 in Chapter 143 of the North Carolina General Statutes. Impacts to isolated and other non-404 jurisdictional wetlands shall not be combined with 404 jurisdictional wetlands for the purpose of determining when impact thresholds trigger a mitigation requirement. For linear publicly owned and maintained transportation projects that are not determined to be part of a larger common plan of development by the US Army Corps of Engineers, compensatory mitigation may be required for losses of greater than 300 linear feet per perennial stream.

P-88
GC4135

Compensatory stream and/or wetland mitigation shall be proposed and completed in compliance with G.S. 143-214.11. For applicants proposing to conduct mitigation within a project site, a complete mitigation proposal developed in accordance with the most recent guidance issued by the US Army Corps of Engineers Wilmington District shall be submitted for review and approval with the application for impacts.

4. All activities shall be in compliance with any applicable State Regulated Riparian Buffer Rules in Chapter 2 of Title 15A.
5. When applicable, all construction activities shall be performed and maintained in full compliance with G.S. Chapter 113A Article 4 (Sediment and Pollution Control Act of 1973). Regardless of applicability of the Sediment and Pollution Control Act, all projects shall incorporate appropriate Best Management Practices for the control of sediment and erosion so that no violations of state water quality standards, statutes, or rules occur. [15A NCAC 02H .0506(b)(3) and (c)(3) and 15A NCAC 02B .0200]

Design, installation, operation, and maintenance of all sediment and erosion control measures shall be equal to or exceed the requirements specified in the most recent version of the *North Carolina Sediment and Erosion Control Manual*, or for linear transportation projects, the *NCDOT Sediment and Erosion Control Manual*.

All devices shall be maintained on all construction sites, borrow sites, and waste pile (spoil) sites, including contractor-owned or leased borrow pits associated with the project. Sufficient materials required for stabilization and/or repair of erosion control measures and stormwater routing and treatment shall be on site at all times.

For borrow pit sites, the erosion and sediment control measures shall be designed, installed, operated, and maintained in accordance with the most recent version of the *North Carolina Surface Mining Manual*. Reclamation measures and implementation shall comply with the reclamation in accordance with the requirements of the Sedimentation Pollution Control Act and the Mining Act of 1971.

If the project occurs in waters or watersheds classified as Primary Nursery Areas (PNAs), SA, WS-I, WS-II, High Quality Waters (HQW), or Outstanding Resource Waters (ORW), then the sedimentation and erosion control designs shall comply with the requirements set forth in 15A NCAC 04B .0124, *Design Standards in Sensitive Watersheds*.

6. Sediment and erosion control measures shall not be placed in wetlands or waters except within the footprint of temporary or permanent impacts authorized under this Certification. Exceptions to this condition require application to and written approval from DWR. [15A NCAC 02H .0501 and .0502]
7. Erosion control matting that incorporates plastic mesh and/or plastic twine shall not be used along streambanks or within wetlands. Exceptions to this condition require application to and written approval from DWR. [15A NCAC 02B .0201]

P-89
GC4135

8. An NPDES Construction Stormwater Permit (NCG010000) is required for construction projects that disturb one (1) or more acres of land. The NCG010000 Permit allows stormwater to be discharged during land disturbing construction activities as stipulated in the conditions of the permit. If the project is covered by this permit, full compliance with permit conditions including the erosion & sedimentation control plan, inspections and maintenance, self-monitoring, record keeping and reporting requirements is required. [15A NCAC 02H .0506(b)(5) and (c)(5)]

The North Carolina Department of Transportation (NCDOT) shall be required to be in full compliance with the conditions related to construction activities within the most recent version of their individual NPDES (NCS000250) stormwater permit. [15A NCAC 02H .0506(b)(5) and (c)(5)]

9. All work in or adjacent to streams shall be conducted so that the flowing stream does not come in contact with the disturbed area. Approved best management practices from the most current version of the *NC Sediment and Erosion Control Manual*, or the *NC DOT Construction and Maintenance Activities Manual*, such as sandbags, rock berms, cofferdams, and other diversion structures shall be used to minimize excavation in flowing water. Exceptions to this condition require application to and written approval from DWR. [15A NCAC 02H .0506(b)(3) and (c)(3)]
10. If activities must occur during periods of high biological activity (e.g. sea turtle nesting, fish spawning, or bird nesting), then biological monitoring may be required at the request of other state or federal agencies and coordinated with these activities. [15A NCAC 02H .0506 (b)(2) and 15A NCAC 04B .0125]

All moratoriums on construction activities established by the NC Wildlife Resources Commission (WRC), US Fish and Wildlife Service (USFWS), NC Division of Marine Fisheries (DMF), or National Marine Fisheries Service (NMFS) shall be implemented. Exceptions to this condition require written approval by the resource agency responsible for the given moratorium. A copy of the approval from the resource agency shall be forwarded to DWR.

Work within a designated trout watershed of North Carolina (as identified by the Wilmington District of the US Army Corps of Engineers), or identified state or federal endangered or threatened species habitat, shall be coordinated with the appropriate WRC, USFWS, NMFS, and/or DMF personnel.

11. Culverts shall be designed and installed in such a manner that the original stream profiles are not altered and allow for aquatic life movement during low flows. The dimension, pattern, and profile of the stream above and below a pipe or culvert shall not be modified by widening the stream channel or by reducing the depth of the stream in connection with the construction activity. The width, height, and gradient of a proposed culvert shall be such as to pass the average historical low flow and spring flow without adversely altering flow velocity. [15A NCAC 02H .0506(b)(2) and (c)(2)]

P-90
GC4135

Placement of culverts and other structures in streams shall be below the elevation of the streambed by one foot for all culverts with a diameter greater than 48 inches, and 20% of the culvert diameter for culverts having a diameter less than or equal to 48 inches, to allow low flow passage of water and aquatic life.

If multiple pipes or barrels are required, they shall be designed to mimic the existing stream cross section as closely as possible including pipes or barrels at flood plain elevation and/or sills where appropriate. Widening the stream channel shall be avoided.

When topographic constraints indicate culvert slopes of greater than 5%, culvert burial is not required, provided that all alternative options for flattening the slope have been investigated and aquatic life movement/connectivity has been provided when possible (e.g. rock ladders, cross vanes, etc.). Notification, including supporting documentation to include a location map of the culvert, culvert profile drawings, and slope calculations, shall be provided to DWR 60 calendar days prior to the installation of the culvert.

When bedrock is present in culvert locations, culvert burial is not required provided that there is sufficient documentation of the presence of bedrock. Notification, including supporting documentation such as, a location map of the culvert, geotechnical reports, photographs, etc. shall be provided to DWR a minimum of 60 calendar days prior to the installation of the culvert. If bedrock is discovered during construction, then DWR shall be notified by phone or email within 24 hours of discovery.

If other site-specific topographic constraints preclude the ability to bury the culverts as described above and/or it can be demonstrated that burying the culvert would result in destabilization of the channel, then exceptions to this condition require application to and written approval from DWR.

Installation of culverts in wetlands shall ensure continuity of water movement and be designed to adequately accommodate high water or flood conditions. When roadways, causeways, or other fill projects are constructed across FEMA-designated floodways or wetlands, openings such as culverts or bridges shall be provided to maintain the natural hydrology of the system as well as prevent constriction of the floodway that may result in destabilization of streams or wetlands.

The establishment of native woody vegetation and other soft stream bank stabilization techniques shall be used where practicable instead of rip-rap or other bank hardening methods.

12. Bridge deck drains shall not discharge directly into the stream. Stormwater shall be directed across the bridge and pre-treated through site-appropriate means to the maximum extent practicable (e.g. grassed swales, pre-formed scour holes, vegetated buffers, etc.) before entering the stream. Exceptions to this condition require application to and written approval from DWR. [15A NCAC 02H .0506(b)(5)]

P-91
GC4135

13. Application of fertilizer to establish planted/seeded vegetation within disturbed riparian areas and/or wetlands shall be conducted at agronomic rates and shall comply with all other Federal, State and Local regulations. Fertilizer application shall be accomplished in a manner that minimizes the risk of contact between the fertilizer and surface waters. [15A NCAC 02B .0200 and 15A NCAC 02B .0231]
14. If concrete is used during construction, then all necessary measures shall be taken to prevent direct contact between uncured or curing concrete and waters of the state. Water that inadvertently contacts uncured concrete shall not be discharged to waters of the state. [15A NCAC 02B .0200]
15. All proposed and approved temporary fill and culverts shall be removed and the impacted area shall be returned to natural conditions within 60 calendar days after the temporary impact is no longer necessary. The impacted areas shall be restored to original grade, including each stream's original cross sectional dimensions, planform pattern, and longitudinal bed profile. For projects that receive written approval, no temporary impacts are allowed beyond those included in the application and authorization. All temporarily impacted sites shall be restored and stabilized with native vegetation. [15A NCAC 02H .0506(b)(2) and (c)(2)]
16. All proposed and approved temporary pipes/culverts/rip-rap pads etc. in streams shall be installed as outlined in the most recent edition of the *North Carolina Sediment and Erosion Control Planning and Design Manual* or the *North Carolina Surface Mining Manual* or the *North Carolina Department of Transportation Best Management Practices for Construction and Maintenance Activities* so as not to restrict stream flow or cause dis-equilibrium during use of this Certification. [15A NCAC 02H .0506(b)(2) and (c)(2)]
17. Any rip-rap required for proper culvert placement, stream stabilization, or restoration of temporarily disturbed areas shall be restricted to the area directly impacted by the approved construction activity. All rip-rap shall be placed such that the original stream elevation and streambank contours are restored and maintained. Placement of rip-rap or other approved materials shall not result in de-stabilization of the stream bed or banks upstream or downstream of the area or in a manner that precludes aquatic life passage. [15A NCAC 02H .0506(b)(2)]
18. Any rip-rap used for stream or shoreline stabilization shall be of a size and density to prevent movement by wave, current action, or stream flows and shall consist of clean rock or masonry material free of debris or toxic pollutants. Rip-rap shall not be installed in the streambed except in specific areas required for velocity control and to ensure structural integrity of bank stabilization measures. [15A NCAC 02H .0506(b)(2)]
19. Applications for rip-rap groins proposed in accordance with 15A NCAC 07H .1401 (NC Division of Coastal Management General Permit for construction of Wooden and Rip-rap Groins in Estuarine and Public Trust Waters) shall meet all the specific conditions for design and construction specified in 15A NCAC 07H .1405.

P-92
GC4135

20. All mechanized equipment operated near surface waters shall be inspected and maintained regularly to prevent contamination of surface waters from fuels, lubricants, hydraulic fluids, or other toxic materials. Construction shall be staged in order to minimize the exposure of equipment to surface waters to the maximum extent practicable. Fueling, lubrication and general equipment maintenance shall be performed in a manner to prevent, to the maximum extent practicable, contamination of surface waters by fuels and oils. [15A NCAC 02H .0506(b)(3) and (c)(3) and 15A NCAC 02B .0211 (12)]
21. Heavy equipment working in wetlands shall be placed on mats or other measures shall be taken to minimize soil disturbance. [15A NCAC 02H .0506(b)(3) and (c)(3)]
22. In accordance with 143-215.85(b), the applicant shall report any petroleum spill of 25 gallons or more; any spill regardless of amount that causes a sheen on surface waters; any petroleum spill regardless of amount occurring within 100 feet of surface waters; and any petroleum spill less than 25 gallons that cannot be cleaned up within 24 hours.
- * 23. If an environmental document is required under the State Environmental Policy Act (SEPA), then this General Certification is not valid until a Finding of No Significant Impact (FONSI) or Record of Decision (ROD) is issued by the State Clearinghouse. If an environmental document is required under the National Environmental Policy Act (NEPA), then this General Certification is not valid until a Categorical Exclusion, the Final Environmental Assessment, or Final Environmental Impact Statement is published by the lead agency. [15A NCAC 01C .0107(a)]
24. This General Certification does not relieve the applicant of the responsibility to obtain all other required Federal, State, or Local approvals before proceeding with the project, including those required by, but not limited to, Sediment and Erosion Control, Non-Discharge, Water Supply Watershed, and Trout Buffer regulations.
25. The applicant and their authorized agents shall conduct all activities in a manner consistent with State water quality standards (including any requirements resulting from compliance with §303(d) of the Clean Water Act), and any other appropriate requirements of State and Federal Law. If DWR determines that such standards or laws are not being met, including failure to sustain a designated or achieved use, or that State or Federal law is being violated, or that further conditions are necessary to assure compliance, then DWR may revoke or modify a written authorization associated with this General Water Quality Certification. [15A NCAC 02H .0507(d)]
26. The permittee shall require its contractors and/or agents to comply with the terms and conditions of this permit in the construction and maintenance of this project, and shall provide each of its contractors and/or agents associated with the construction or maintenance of this project with a copy of this Certification. A copy of this Certification, including all conditions shall be available at the project site during the construction and maintenance of this project. [15A NCAC 02H .0507 (c) and 15A NCAC 02H .0506 (b)(2) and (c)(2)]

P-93
GC4135

- * 27. When written authorization is required for use of this Certification, upon completion of all permitted impacts included within the approval and any subsequent modifications, the applicant shall be required to return a certificate of completion (available on the DWR website <https://edocs.deq.nc.gov/Forms/Certificate-of-Completion>). [15A NCAC 02H .0502(f)]
- 28. Additional site-specific conditions, including monitoring and/or modeling requirements, may be added to the written approval letter for projects proposed under this Water Quality Certification in order to ensure compliance with all applicable water quality and effluent standards. [15A NCAC 02H .0507(c)]
- 29. If the property or project is sold or transferred, the new permittee shall be given a copy of this Certification (and written authorization if applicable) and is responsible for complying with all conditions. [15A NCAC 02H .0501 and .0502]

III. GENERAL CERTIFICATION ADMINISTRATION:

- * 1. In accordance with North Carolina General Statute 143-215.3D(e), written approval for a 401 Water Quality General Certification must include the appropriate fee. An applicant for a CAMA permit under Article 7 of Chapter 113A of the General Statutes for which a Water Quality Certification is required shall only make one payment to satisfy both agencies; the fee shall be as established by the Secretary in accordance with 143-215.3D(e)(7).
- 2. This Certification neither grants nor affirms any property right, license, or privilege in any waters, or any right of use in any waters. This Certification does not authorize any person to interfere with the riparian rights, littoral rights, or water use rights of any other person and this Certification does not create any prescriptive right or any right of priority regarding any usage of water. This Certification shall not be interposed as a defense in any action respecting the determination of riparian or littoral rights or other rights to water use. No consumptive user is deemed by virtue of this Certification to possess any prescriptive or other right of priority with respect to any other consumptive user regardless of the quantity of the withdrawal or the date on which the withdrawal was initiated or expanded.
- 3. This Certification grants permission to the Director, an authorized representative of the Director, or DWR staff, upon the presentation of proper credentials, to enter the property during normal business hours. [15A NCAC 02H .0502(e)]
- 4. This General Certification shall expire on the same day as the expiration date of the corresponding Nationwide Permit and/or Regional General Permit. The conditions in effect on the date of issuance of Certification for a specific project shall remain in effect for the life of the project, regardless of the expiration date of this Certification. This General Certification is rescinded when the US Army Corps of Engineers reauthorizes any of the corresponding Nationwide Permits and/or Regional General Permits or when deemed appropriate by the Director of the Division of Water Resources.

P-94
GC4135

5. Non-compliance with or violation of the conditions herein set forth by a specific project may result in revocation of this General Certification for the project and may also result in criminal and/or civil penalties.
- * 6. The Director of the North Carolina Division of Water Resources may require submission of a formal application for Individual Certification for any project in this category of activity if it is deemed in the public's best interest or determined that the project is likely to have a significant adverse effect upon water quality, including state or federally listed endangered or threatened aquatic species, or degrade the waters so that existing uses of the water or downstream waters are precluded.

History Note: Water Quality Certification (WQC) Number 4135 issued December 1, 2017 replaces WQC Number 4088 issued March 3, 2017; WQC 3886 issued March 12, 2012; WQC Number 3820 issued April 6, 2010; WQC Number 3627 issued March 2007; WQC Number 3404 issued March 2003; WQC Number 3375 issued March 18, 2002; WQC Number 3289 issued June 1, 2000; WQC Number 3103 issued February 11, 1997; WQC Number 2732 issued May 1, 1992; WQC Number 2666 issued January 21, 1992; WQC Number 2177 issued November 5, 1987.



Energy, Mineral
and Land Resources
ENVIRONMENTAL QUALITY

P-95

ROY COOPER
Governor

MICHAEL S. REGAN
Secretary

WILLIAM E. VINSON, JR.
Interim Director

August 28, 2018

Mr. David McHenry
Environmental Officer
N C Department of Transportation/ Division 14
253 Webster Road
Sylva, NC 28779

Subject: Trout Buffer Zone Waiver
TIP R5734A
Macon County

Dear Mr. McHenry:

This office has received your plan for widening on US 441 over and adjacent to Cartoogechaye Creek and upper tributaries in Macon County, North Carolina. Your plan was submitted to this office for approval because of the proposed encroachments into the buffer zone of designated trout waters. In accordance with NCGS 113A-57(1) and Title 15A NCAC 4B .0125(c) this letter will serve as written approval to encroach on the buffer zone of the Cartoogechaye Creek Class B; Trout and its unnamed tributaries. This authority has been delegated to me by William E. (Toby) Vinson, Jr., Interim Director, Division of Energy, Mineral and Land Resources. This approval is based on the plans received via email on May 4, 2018. The following conditions will apply to this approval:

1. It is required that the plantings in the trout buffer are selected from the attached Guidelines for Riparian Buffer Restoration. (15A NCAC 04B .0125(d))
2. Staging areas and material stockpiles shall be located out of the trout buffer zone. Stockpiles will be encompassed with silt fence excluding points of access. (G.S. 113A-57)

3. Contact the North Carolina Wildlife Resources Commission to determine if a moratorium between October 15 and April 15 is applicable. The contact information is:

Andrea Leslie
Mountain Habitat Conservation Coordinator
NC Wildlife Resources Commission
20830 Great Smoky Mountain Expressway
Waynesville, NC 28786
828-558-6011; 828-400-4223 (cell)
www.ncwildlife.org

4. This approval does not absolve the permittee from compliance with the surface water turbidity standard. More protective erosion and sedimentation control measures may be required to comply with this water quality standard. (G.S. 113A-54.1(a))

Your cooperation in protecting our environment is most appreciated. If you have any questions about this approval, please contact me at stan.aiken@ncdenr.gov or (828) 296-4610.

Sincerely,

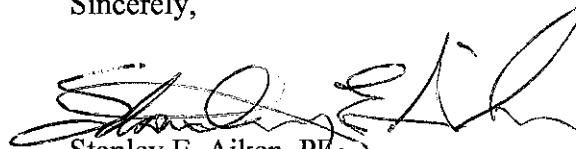

Stanley E. Aiken, PE^{EA}
Regional Engineer
Land Quality Section

Enclosure: Guidelines for Riparian Buffer Restoration

cc: William E. Vinson, Jr, PE, CPESC, CPM, Interim Director, DEMLR
(toby.vinson@ncdenr.gov)
Julie Coco, PE, State Sediment Specialist (julie.coco@ncdenr.gov)
Zan Price, PE, Division of Water Resources (zan.price@ncdenr.gov)
David McHenry, Environmental Officer, NCDOT (dgmchenry@ncdot.gov)

Guidelines for Riparian Buffer Restoration

Department of Environment and Natural Resources
Division of Water Quality
Wetlands Restoration Program
Raleigh, NC
January 2001



Purpose of these Guidelines

Riparian buffers have been identified as a valuable tool for protection of water quality when properly designed and established in the appropriate landscape setting. For this reason, the goal of the North Carolina Wetlands Restoration Program (NCWRP) is to implement projects to restore riparian buffers that have the greatest value for reducing pollutants in our surface waters as well as provide important aquatic and wildlife habitat. The purpose of these guidelines is to provide the technical information necessary for the successful planning and establishment of riparian buffers. The guidelines are intended for use by private consultants in developing restoration plans for the NCWRP but should also have utility for private landowners as well as local governments involved in the restoration of riparian buffers.



Criteria for Priority
Riparian Buffer Restoration Projects

A number of factors determine the success of particular riparian buffer restoration projects. In addition to the physical characteristics of the site, issues such as land costs, land ownership, and logistical constraints must be taken into consideration. The following physical characteristics are intended to provide general guidance when identifying sites and are not intended to exclude sites that may have merit based on other criteria.

- Woody vegetation absent or sparse (less than 100 stems per acre that are ≥ 5 inches diameter at breast height) measured within 50 feet of intermittent and perennial streams, lakes, ponds, and shorelines.
- Adjacent to headwater streams or those streams defined as first, second, or third order.
- Project length greater than 1,000 feet (for projects implemented by the NCWRP).
- Ditches, gullies, or evidence of concentrated flow within 50 feet of intermittent and perennial streams, lakes, ponds, and estuaries.
- Adjacent source of nitrogen including cropland, pasture, golf course, residential development, ball fields, etc.
- Water table depth within three to four feet of surface as determined by characteristics of soil cores.



Components of a Riparian Buffer
Restoration/Enhancement Plan

Site Assessment

The riparian area to be restored should be evaluated with respect to these factors that control the viability of riparian plants:

- Soil moisture
- Soil pH
- Soil texture
- Seasonal high water table depth
- Flooding potential
- Aspect, topography, and microtopographic relief

Site Preparation

The restoration/enhancement plan should address these items regarding preparation of the site for planting:

- Plow or rip site to improve compacted soil and/or eliminate areas where channelized flow has developed.
- Control of sod-forming grasses such as fescue and Kentucky bluegrass that will compete with plantings for nutrients.
- Control of invasive, exotic plants that would hinder the re-establishment of woody vegetation. Proposals for pesticide use should always be reviewed by the North Carolina Division of Water Quality staff to insure compliance with the Neuse and Tar-Pamlico Riparian Buffer Rules.

Common Invasive Exotic Plants
in North Carolina
Ailanthus altissima (Tree-of-Heaven)
Albizia julibrissin (Mimosa)
Elaeagnus umbellata (Autumn
Olive)
Hedera helix (English Ivy)
Lespedeza cuneata (Korean or
Sericea Lespedeza)
Ligustrum sinense (Chinese Privet)
Lonisera japonica (Japanese
Honeysuckle)
Microstegium vimineum (Japanese
Grass)
Paulownia tomentosa (Princess
Tree)
Pueraria lobata (Kudzu)
Rosa multiflora (Multiflora Rose)
Wisteria sinensis (Chinese Wisteria)

- Stabilize areas of bare soil. Refer to the following list for species of grasses/sedge appropriate for soil stabilization. The majority of these species are by necessity not native to North Carolina. At present, there are only a few species of native grasses useful for erosion control that are commercially available. Please note that fescue grasses should not be used for soil stabilization. Fescue grasses, particularly tall fescue, are competitive and will inhibit the eventual re-establishment of native species.

Agrostis alba (Redtop)

Found in fields, pastures, roadsides, and other disturbed places throughout North Carolina, this native warm season grass should be

used sparingly for erosion control and soil stabilization.

Carex stricta (Sedge)

This sedge occurs naturally in marshes and low meadows throughout the mountains and northern piedmont and coastal plain of North Carolina. This species has utility in a mix for soil stabilization in moist areas.

Dactylis glomerata (Orchardgrass)

This perennial, cool season bunchgrass is a good alternative to fescue because it is less competitive and allows native herbs to colonize the site.

Hordeum spp. (Barley)

A number of species of barley can be used for soil stabilization. Barley is a cool season, annual grass that when moisture is available will germinate in the fall, stay green during the winter, and then die in the spring as competition for warm season plants increases.

Panicum clandestinum (Deer
Tongue)

This native, perennial, warm season bunchgrass can be used in moist low woods primarily in the piedmont and mountains.

Panicum spp. (Panic Grasses)

A number of species of panic grasses can be used for soil stabilization

depending on the moisture regime and soils of the site.

Panicum virgatum (Switchgrass)

This native, perennial, warm season bunchgrass can tolerate a wide range of moisture regimes. It can be used along streams, in wet or dry woods, brackish and freshwater marshes, sloughs, swales, and low pinelands primarily in the eastern piedmont and coastal plain.

Pennisetum glaucum (Brown Top or Pearl Millet)

This fast-growing, robust, annual grass exhibits good drought tolerance which makes this species an important warm season option for soil stabilization.

Phalaris arundinacea (Reed Canarygrass)

A native to North Carolina, this perennial cool season grass is used for the stabilization of pond shorelines, drainage ditches, and streambanks in the mountains and western piedmont. It is established by planting freshly cut stem slips or rhizome fragments. Please note that this species is aggressive and forms large monotypic stands that displace other species. It should only be used if no other species are available.

Secale cereale (Winter Rye or Rye Grain)

Winter rye is a cold-hardy annual grass that will germinate and grow at low temperatures. By maturing early, it offers less competition

during the late spring, a critical time in the establishment of perennial species. Winter rye germinates quickly and is tolerant of poor soils.

Sorghum bicolor (Sudangrass)

Only the small-stemmed varieties of this annual warm season grass should be used. Sudangrass is useful for temporary seeding, and it is adapted to soils relatively high in clay content. Seed for common Sudangrass is not always available, but other small-stemmed types may be used, such as the hybrid Trudan. The coarse-stemmed Sorghum-Sudangrass hybrids are not appropriate for erosion control.

Suppliers of Grass Seed*

Ernst Conservation Seeds
9006 Mercer Pike
Meadville, PA 16335
814-336-2404
800-873-3321

Lofts Seed Company, Inc.
P.O. Box 26223
Winston-Salem, NC 27114-6223
800-543-7333

Mellow Marsh Farm
205 Anolis Road
Pittsboro, NC 27312
919-542-3532

Southern Tier Consulting, Inc.
2701-A Route 305
P.O. Box 30
West Clarksville, NY 14786
800-848-7614

*North Carolina suppliers are preferred.



Riparian Buffer Design

Species Diversity and Composition

The most effective riparian buffers have trees and shrubs to provide perennial root systems and long-term nutrient storage. The design of a riparian buffer can be modified to fit the landscape and the landowner's needs, for example, by replacing shrubs with more trees, substituting some of the trees with shrubs, or incorporating a grass zone. In any scenario, the width of the woody vegetation should be at least 30 feet directly adjacent to the streambank/shoreline.

Choose 10-12 species of native trees and/or shrubs appropriate for site based on site assessment and reference conditions. In addition, please note that this list is alphabetical and does not take into account the assemblages of plants

found in nature. The inventory of plants found on the reference site can help determine an appropriate assemblage for the restoration site. In addition, the North Carolina Natural Heritage Program's *Classification of the Natural Communities of North Carolina: Third Approximation* is a valuable reference on natural assemblages of plants (Shafele, Michael P. and Alan S. Weakley, 1990).

Typically, there should be at least three or four understory trees for every canopy tree to provide structural diversity similar to mature forests. Where shrub species are incorporated into the planting plan, they should be distributed more densely at outer edge of riparian buffer to reduce light penetration and recolonization by invasive exotic species. Refer to Table 1 for a list of native tree and shrub species appropriate for use in riparian buffers.

Table 1. Master List of Native Plants

Native Regions	Light Requirements	Moisture Requirements
M= Mountains	S= Shade	L= Low Moisture
P= Piedmont	P= Partial Sun	M= Moderate Moisture
C= Coastal Plain	F= Full Sun	H= High Moisture
		A= Aquatic

Scientific Name	Common Name	Region			Light			Moisture				
		M	P	C	S	P	F	L	M	H	A	
Medium to Large Trees												
<i>Acer barbatum</i>	Southern sugar maple		X	X	X	X				X		
<i>Acer saccharinum</i>	silver maple		X		X	X	X		X			
<i>Acer saccharum</i>	sugar maple	X				X	X		X			
<i>Betula alleghaniensis</i>	yellow birch	X			X	X			X			
<i>Betula lenta</i>	cherry birch, sweet birch	X			X	X			X			
<i>Betula nigra</i>	river birch	X	X	X		X	X		X	X		
<i>Carya aquatica</i>	water hickory				X	X	X			X		
<i>Carya cordiformis</i>	bitternut hickory	X	X	X	X	X	X		X	X		
<i>Carya glabra</i>	pignut hickory	X	X	X	X	X	X	X	X			

P-102

Scientific Name	Common Name	Region			Light			Moisture						
		M	P	C	S	P	F	L	M	H	A			
<i>Carya ovata</i>	shagbark hickory	X	X	X	X	X	X	X						
<i>Carya tomentosa</i>	mockernut hickory	X	X	X	X	X	X	X	X					
<i>Celtis laevigata</i>	sugarberry, hackberry		X	X	X	X				X				
<i>Chamaecyparis thyoides</i>	Atlantic white cedar			X		X	X			X	X			
<i>Cladrastis kentuckea</i>	yellowwood	X			X	X				X				
<i>Diospyros virginiana</i>	persimmon	X	X	X	X	X	X	X	X	X				
<i>Fagus grandifolia</i>	American beech	X	X	X	X	X				X				
<i>Fraxinus americana</i>	white ash	X	X	X	X	X				X				
<i>Fraxinus pennsylvanica</i>	green ash	X	X	X	X	X				X	X			
<i>Fraxinus profunda</i>	pumpkin ash, red ash		X	X		X						X		
<i>Juglans nigra</i>	black walnut	X	X	X	X	X				X				
<i>Liriodendron tulipifera</i>	tulip poplar, yellow poplar	X	X	X	X	X	X			X				
<i>Magnolia acuminata</i>	cucumber magnolia	X	X		X	X				X				
<i>Magnolia fraseri</i>	Fraser magnolia	X				X				X				
<i>Nyssa aquatica</i>	water tupelo			X	X	X	X				X	X		
<i>Nyssa sylvatica</i>	black gum	X	X	X	X	X	X	X	X	X				
<i>Nyssa sylvatica var. biflora</i>	swamp black gum			X	X	X	X				X			
<i>Oxydendrum arboreum</i>	sourwood	X	X	X		X	X	X	X	X				
<i>Picea rubens</i>	red spruce	X			X	X	X			X				
<i>Pinus echinata</i>	shortleaf pine	X	X	X		X	X	X						
<i>Pinus palustris</i>	longleaf pine		X	X			X	X	X					
<i>Pinus rigida</i>	pitch pine	X					X	X						
<i>Pinus serotina</i>	pond pine			X			X		X	X				
<i>Pinus strobus</i>	white pine	X	X			X	X			X				
<i>Platanus occidentalis</i>	sycamore	X	X	X		X	X			X	X			
<i>Populus deltoides</i>	eastern cottonwood		X	X			X				X			
<i>Populus heterophylla</i>	swamp cottonwood			X		X	X				X			
<i>Prunus serotina</i>	black cherry	X	X	X	X	X	X	X	X	X				
<i>Quercus alba</i>	white oak	X	X	X		X	X	X	X	X				
<i>Quercus bicolor</i>	swamp white oak		X		X	X					X			
<i>Quercus coccinea</i>	scarlet oak	X	X		X	X				X				
<i>Quercus falcata</i>	Southern red oak	X	X	X	X	X				X	X			
<i>Quercus pagoda</i>	cherrybark oak		X	X	X	X					X	X		
<i>Quercus laurifolia</i>	laurel oak			X	X	X	X				X	X		
<i>Quercus lyrata</i>	overcup oak		X	X	X	X						X		
<i>Quercus margaretta</i>	sand post oak			X		X	X	X						
<i>Quercus marilandica</i>	black jack oak	X	X	X	X	X				X				
<i>Quercus michauxii</i>	swamp chestnut oak		X	X	X	X	X				X	X		
<i>Quercus nigra</i>	water oak		X	X	X	X	X	X	X					
<i>Quercus phellos</i>	willow oak		X	X	X	X	X				X	X		
<i>Quercus prinus</i>	chestnut oak	X	X		X	X				X				
<i>Quercus rubra</i>	Northern red oak	X	X		X	X				X	X			
<i>Quercus shumardii</i>	shumard oak		X	X	X	X					X	X		
<i>Quercus stellata</i>	post oak	X	X	X	X	X				X				
<i>Quercus velutina</i>	black oak	X	X	X	X	X				X				
<i>Quercus virginiana</i>	live oak			X		X	X	X						
<i>Robinia pseudoacacia</i>	black locust	X	X	X		X	X			X				
<i>Taxodium ascendens</i>	pond-cypress			X		X	X						X	
<i>Taxodium distichum</i>	bald-cypress			X		X	X							X

P-103

Scientific Name	Common Name	Region			Light			Moisture				
		M	P	C	S	P	F	L	M	H	A	
<i>Tilia americana</i> var. <i>heterophylla</i>	basswood	X	X		X	X			X			
<i>Tsuga canadensis</i>	Eastern hemlock	X	X		X	X	X		X			
<i>Tsuga caroliniana</i>	Carolina hemlock	X	X			X	X	X				
<i>Ulmus alata</i>	winged elm		X	X	X	X	X	X	X			
<i>Ulmus americana</i>	American elm	X	X	X	X	X			X			
Small Trees												
<i>Amelanchier arborea</i>	downy serviceberry, shadbush	X	X	X	X	X			X			
<i>Amelanchier canadensis</i>	Canada serviceberry			X			X		X	X		
<i>Amelanchier laevis</i>	smooth serviceberry	X				X	X	X	X			
<i>Asimina triloba</i>	pawpaw	X	X	X	X	X			X			
<i>Carpinus caroliniana</i>	ironwood, American hornbeam	X	X	X	X	X			X	X		
<i>Cercis canadensis</i>	eastern redbud	X	X	X	X	X			X			
<i>Chionanthus virginicus</i>	white fringetree, old man's beard	X	X	X		X	X		X			
<i>Cornus alternifolia</i>	alternate-leaf dogwood	X			X	X			X			
<i>Cornus florida</i>	flowering dogwood	X	X	X	X	X		X	X			
<i>Crateagus crus-galli</i>	cockspur hawthorn	X	X	X		X	X	X	X			
<i>Crateagus flabellata</i>	fanleaf hawthorn	X	X			X			X			
<i>Crateagus flava</i>	October haw	X	X	X		X	X		X			
<i>Cyrilla racemiflora</i>	titi			X		X	X		X	X		
<i>Fraxinus caroliniana</i>	water ash			X	X	X				X		
<i>Gordonia lasianthus</i>	loblolly bay			X	X	X	X		X	X		
<i>Halesia tetraptera</i> (<i>H. carolina</i>)	common silverbell	X	X		X	X			X			
<i>Ilex opaca</i>	American holly	X	X	X	X	X		X	X	X		
<i>Juniperus virginiana</i>	Eastern red cedar	X	X	X		X	X	X	X			
<i>Magnolia tripetala</i>	umbrella tree	X	X		X				X			
<i>Magnolia virginiana</i>	sweetbay magnolia		X	X	X	X	X		X	X		
<i>Morus rubra</i>	red mulberry	X	X	X	X	X			X			
<i>Osmanthus americana</i>	wild olive, devilwood			X	X	X			X			
<i>Ostrya virginiana</i>	Eastern hop-hornbeam	X	X		X	X			X			
<i>Persea borbonia</i>	red bay			X	X	X	X	X	X			
<i>Persea palustris</i>	swamp bay			X	X	X	X		X	X		
<i>Pinus pungens</i>	table mountain pine	X						X	X			
<i>Prunus americana</i>	American wild plum	X	X			X			X			
<i>Prunus caroliniana</i>	Carolina laurel-cherry			X		X	X	X	X			
<i>Quercus incana</i>	bluejack oak			X		X	X	X				
<i>Quercus laevis</i>	turkey oak			X		X	X	X				
<i>Rhus glabra</i>	smooth sumac	X	X					X	X	X		
<i>Rhus hirta</i> (<i>Rhus typhina</i>)	staghorn sumac	X						X	X			
<i>Salix caroliniana</i>	swamp willow	X	X	X		X	X		X	X		
<i>Salix nigra</i>	black willow	X	X	X		X	X		X	X		
<i>Sassafras albidum</i>	sassafras	X	X	X		X	X	X	X			
<i>Staphylea trifolia</i>	bladdernut		X		X				X	X		
<i>Symplocos tinctoria</i>	horse-sugar, sweetleaf	X	X	X	X	X			X	X		
<i>Ulmus rubra</i>	slippery elm	X	X		X	X			X			
Shrubs												
<i>Aesculus sylvatica</i>	painted buckeye	X	X		X	X			X			
<i>Alnus serrulata</i> *	common alder	X	X	X	X	X	X			X	X	

Scientific Name	Common Name	Region			Light			Moisture				
		M	P	C	S	P	F	L	M	H	A	
<i>Aronia arbutifolia</i>	red chokeberry	X	X	X	X	X			X	X		
<i>Baccharis halimifolia</i>	silverling		X	X			X	X	X	X		
<i>Callicarpa americana</i>	American beautyberry		X	X	X	X	X		X			
<i>Calycanthus floridus</i>	sweet-shrub	X	X		X	X			X			
<i>Castanea pumila</i>	Allegheny chinkapin	X	X	X	X	X	X	X				
<i>Ceanothus americanus</i>	New Jersey tea	X	X	X		X	X	X				
<i>Cephalanthus occidentalis</i>	buttonbush	X	X	X		X	X					X
<i>Clethra acuminata</i>	mountain sweet pepperbush	X			X	X			X			
<i>Clethra alnifolia</i>	sweet pepperbush			X	X	X			X	X		
<i>Comptonia peregrina</i>	sweet fern	X	X			X	X					
<i>Cornus amomum</i>	silky dogwood	X	X	X	X	X				X	X	
<i>Cornus stricta</i>	swamp dogwood			X	X	X				X		
<i>Corylus americana</i>	American hazel, hazelnut	X	X		X	X			X			
<i>Euonymus americanus</i>	hearts-a-bustin', strawberry bush	X	X	X	X	X		X	X			
<i>Fothergilla gardenii</i>	witch-alder			X	X				X	X		
<i>Gaylussacia frondosa</i>	dangleberry			X	X	X	X		X	X		
<i>Hamamelis virginiana</i>	witch hazel	X	X	X	X	X		X	X			
<i>Hydrangea arborescens</i>	wild hydrangea	X	X		X	X			X			
<i>Ilex coriacea</i>	gallberry			X	X	X			X	X		
<i>Ilex decidua</i>	deciduous holly, possumhaw		X	X	X	X			X			
<i>Ilex glabra</i>	inkberry			X	X	X	X		X	X		
<i>Ilex verticillata</i>	winterberry	X	X	X	X	X	X		X	X		
<i>Ilex vomitoria</i>	yaupon holly			X	X	X	X	X				
<i>Itea virginica</i>	Virginia willow		X	X	X	X				X		
<i>Kalmia angustifolia var. caroliniana</i>	lamb-kill, sheep-kill			X	X	X			X	X		
<i>Kalmia latifolia</i>	mountain laurel	X	X		X	X		X	X			
<i>Leucothoe axillaris</i>	coastal dog-hobble			X	X	X			X			
<i>Leucothoe fontanesiana</i>	dog-hobble	X	X		X				X			
<i>Leucothoe racemosa</i>	fetterbush		X	X	X	X			X	X		
<i>Lindera benzoin</i>	spicebush	X	X		X				X			
<i>Lyonia ligustrina</i>	northern maleberry	X	X	X		X			X	X		
<i>Lyonia lucida</i>	shining fetterbush			X	X	X			X			
<i>Myrica cerifera*</i>	Southern wax-myrtle		X	X	X	X	X	X	X	X		
<i>Myrica cerifera var. pumila*</i>	dwarf Southern wax-myrtle			X	X	X	X	X	X			
<i>Myrica heterophylla*</i>	bayberry, evergreen bayberry			X	X	X			X			
<i>Pieris floribunda</i>	evergreen mountain fetterbush	X					X	X	X			
<i>Rhododendron atlanticum</i>	dwarf azalea			X	X				X			
<i>Rhododendron calendulaceum</i>	flame azalea	X			X	X			X			
<i>Rhododendron catawbiense</i>	Catawba rhododendron	X	X		X	X	X	X	X			
<i>Rhododendron maximum</i>	rosebay rhododendron	X	X		X	X			X	X		
<i>Rhododendron periclymenoides</i>	pinxter flower, wild azalea	X	X	X	X	X			X			
<i>Rhododendron viscosum</i>	swamp azalea	X	X		X	X			X	X		
<i>Rhus copallina</i>	winged sumac	X	X	X		X	X	X	X			
<i>Rosa carolina</i>	pasture rose, Carolina rose	X	X	X		X	X	X	X			
<i>Rosa palustris</i>	swamp rose	X	X	X		X	X					X
<i>Rubus allegheniensis</i>	Alleghany blackberry	X	X				X	X				
<i>Rubus cuneifolius</i>	blackberry		X	X		X	X	X	X			
<i>Rubus odoratus</i>	purple flowering raspberry	X				X			X			
<i>Salix humilis</i>	prairie willow	X	X				X	X				

Scientific Name	Common Name	Region			Light			Moisture				
		M	P	C	S	P	F	L	M	H	A	
<i>Salix sericea</i>	silky willow	X	X	X		X	X					X
<i>Sambucus canadensis</i>	common elderberry	X	X	X			X		X	X		
<i>Spiraea alba</i>	narrow-leaved meadowsweet	X					X		X			
<i>Spiraea latifolia</i>	broad-leaved meadowsweet	X					X		X			
<i>Spiraea tomentosa</i>	meadowsweet	X	X	X		X	X				X	
<i>Stewartia malacodendron</i>	silky camellia			X	X	X			X			
<i>Stewartia ovata</i>	mountain camellia	X	X		X	X			X			
<i>Styrax grandifolia</i>	bigleaf snowbell		X	X	X	X			X			
<i>Vaccinium arboreum</i>	sparkleberry		X	X	X	X		X	X			
<i>Vaccinium corymbosum</i>	highbush blueberry	X	X	X	X	X	X	X	X	X		
<i>Vaccinium crassifolium</i>	creeping blueberry			X		X			X			
<i>Vaccinium elliotii</i>	mayberry			X	X				X			
<i>Vaccinium stamineum</i>	deerberry, gooseberry	X	X	X	X	X		X				
<i>Vaccinium pallidum</i>	lowbush blueberry	X	X		X	X		X				
<i>Viburnum acerifolium</i>	maple-leaf viburnum	X	X		X	X		X	X			
<i>Viburnum dentatum</i>	Southern arrowwood viburnum	X	X	X	X	X	X		X			
<i>Viburnum nudum</i>	possumhaw viburnum	X	X	X	X	X					X	
<i>Viburnum prunifolium</i>	blackhaw viburnum	X	X	X	X	X			X			
<i>Viburnum rafinesquianum</i>	downy arrowwood		X	X	X	X			X			
<i>Viburnum rufidulum</i>	rusty blackhaw		X	X	X	X		X				
<i>Xanthorhiza simplicissima</i>	yellowroot	X	X	X	X			X	X			

* These species fix nitrogen and should not be used for riparian restoration adjacent to Nutrient Sensitive Waters.

Where grasses are incorporated into the planting plan on the outside of the buffer strip, only native grasses should be used. Native grasses produce a much more extensive and deep root system than commonly used non-native grasses such as fescue.

- Common Native Grasses
- Andropogon gerardii* (Big Bluestem)
 - Andropogon virginicus* (Broomsedge)
 - Arundinaria gigantea* (Giant Cane)
 - Eragrostis spectabilis* (Purple Love Grass)
 - Panicum anceps* (Beaked Panicum)
 - Panicum clandestinum* (Deertongue)
 - Panicum hemitomon* (Maidencane)
 - Panicum virgatum* (Switchgrass)
 - Schizachyrium scoparium* (Little Bluestem)
 - Sorghastrum nutans* (Indiangrass)
 - Tridens flavus* (Purple-Top)
 - Tripsacum dactyloides* (Gama Grass)

Planting Density

Trees should be planted at a density sufficient to provide 320 trees per acre at maturity. To achieve this density, approximately 436 (10x10 feet spacing) to 681 (8x8 feet spacing) trees per acre should be planted initially. Shrubs should be planted at a density sufficient to provide 1,200 shrubs per acre. Refer to Table 2 for the number of trees and shrubs per acre based on various methods of spacing.

Table 2. Number of Trees/Shrubs per Acre by Various Methods of Spacing

Spacing (feet)	Trees/Shrubs (number)
2x2	10,890
3x3	4,840
4x4	2,722
5x5	1,742
6x6	1,210
7x7	889
8x8	681
9x9	538
10x10	436
11x11	360
12x12	302
13x13	258



Plant Size

In many cases, the most cost effective and successful size plant material is bare root seedlings. Some species such as the hickories do poorly as bare root seedlings and will be much more successful as containerized seedlings. In either case, tree shelters should be used to accelerate growth and increase survivability of seedlings. In addition, management of competing vegetation after planting is easier, mowing and weed wacker strikes are prevented, herbicides are isolated from trunk contact, and grazing by deer are restricted. The use of tree shelters may only be practical from an economic standpoint for more expensive seedlings of species difficult to establish, such as red oak. Reductions in maintenance costs and increased seedling vigor associated with tree shelters suggest that tree shelter plantings may be a more cost-effective approach than planting unprotected larger material. In urban or other high visibility areas, some specimen trees and shrubs should be incorporated into the planting plan for projects implemented by the NCWRP.

When live stakes or dormant cuttings are incorporated in a planting plan, choose only the previous season's growth. Live stakes should typically be approximately 3/4 inch in diameter and three feet long, and dormant cuttings should be approximately 1/2 inch in diameter and two feet long.

Supplier of Tree Shelters:
 Treessentials Company
 2371 Waters Drive
 Mendota Heights, MN 55120-1163
 800-248-8239

Suppliers of Native Plant Material

Local nurseries are the best option in acquiring plants that will be successful. Plants grown from seeds or cuttings collected close to the restoration area will be the most likely to survive and reproduce. The following is a list of nurseries that supply native plant material. This list is not considered exhaustive or an endorsement by the NCWRP but merely a source of potential vendors of native plants.

Carolina Greenery
375 Carthage Road
West End, NC 27376-8731
910-947-3150

Cedar Point Nursery and Garden Center
100 Commercial Court
Swansboro, NC 28584
252-393-6880

Coastal Plain Conservation Nursery
3067 Conners Drive
Edenton, NC 27932
252-482-5707

Cure Nursery
880 Buteo Road
Pittsboro, NC 27312
919-542-6186

Denton's Nursery
3535 NC 42 West
Wilson, NC 27893
252-237-0022

Fern Valley Farms
1624 Fern Valley Road
Yadkinville, NC 27055
336-463-2412

Hoffman Nursery
5520 Bahama Road
Rougemont, NC 27572
919-479-6620

Laurel Springs Nursery
401 Regal Street
Hendersonville, NC 28792
828-692-4012
888-823-4622

McLamb Nursery, Inc.
640 Greenleaf Road
Angier, NC 27501-9801
919-894-3709
800-900-3709

Mellow Marsh Farm
205 Anolis Road
Pittsboro, NC 27312
919-542-3532

NC Division of Forest Resources
Claridge Nursery
762 Claridge Nursery Road
Goldsboro, NC 27530
919-731-7988

NC Division of Forest Resources
Edwards Nursery
701 Sanford Drive
Morganton, NC 28655
828-438-6270

NC Division of Forest Resources
Linville Nursery
6321 Linville Falls Highway
Newland, NC 28657
828-733-5236

Niche Gardens
1111 Dawson Road
Chapel Hill, NC 27516
919-967-0078

We-Du Nurseries
Rt. 5, Box 724
Marion, NC 28752
828-738-8300

Taylor's Nursery, Inc.
3705 New Bern Avenue
Raleigh, NC 27610
919-231-6161

Woodlander's, Inc.
1128 Colleton Ave.
Aiken, SC 29801
803-648-7522

Wa Ya Nursery & Tree Farm
11199 Canada Road
Tuckasegee, NC 28783
828-293-5720

For more information about suppliers of native plants contact:

Native Plant Sources'
North Carolina Botanical Garden
University of North Carolina at Chapel Hill
CB 3375, Totten Center
Chapel Hill, NC 27599-3375
919-962-0522

Planting Layout

The planting plan should indicate that trees and shrubs will be planted in a random pattern. For inexperienced planting crews, pre-labeled flagged wires can be used to mark the random location of plantings. These flags can also be color coded for each particular species. Various colors of spray paint can also be used to differentiate species.

Planting Practices

When planting seedlings, it is helpful to mark the plants with colored flagging to make them easier to locate during maintenance tasks. The flagging can also be color-coded to mark plants that have died for replacement at a later date.

Tree protectors are also helpful for locating plants.

Tree seedlings should be kept moist and should not be exposed for extended periods of time. A correctly planted tree should have the following general characteristics:

- Planted so that the root collar is slightly below the soil surface.
- Have the main roots nearly straight or spread out.
- Have soil firm around the roots.
- Have the tree in an upright position and have it nearly even with the general ground level, not sunk in a hole or raised on a mound.

Please note that the Neuse and Tar-Pamlico Riparian Buffer Rules allow for a one time fertilizer application to establish newly planted vegetation. Ongoing fertilizer application is prohibited by these rules.



Riparian Buffer Maintenance

Control of Grasses and Forbs

In the early stages of riparian buffer establishment, competition for nutrients by adjacent grasses and forbs will substantially inhibit seedling growth. Release from herbaceous competition has been demonstrated as the most cost-effective method to accelerate the growth of seedlings. The plan for buffer establishment must incorporate control of the herbaceous layer. Options for weed control include four to six inches of well-aged hardwood mulch, weed control fabrics, or pre-emergent herbicide. Typically, mowing to control

weeds will be impractical based on the random distribution of plantings. Weed control should be continued for three years from the time of planting.

Areas of Concentrated Flow

During the required five year monitoring period, the riparian buffer should be inspected for evidence of concentrated flow. If concentrated flow has begun to form, a level spreader or other best management practice should be installed to diffuse the flow before it enters the restored riparian buffer.

Prepared by Cherri L. Smith, North Carolina Wetlands Restoration Program. Illustrations by Karen M. Lynch and design by Marcia Nye.

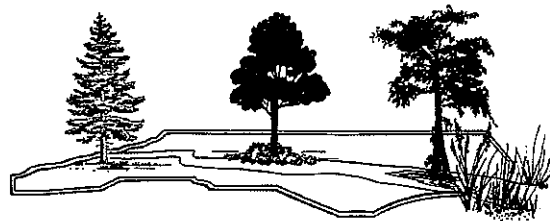

N.C. Wetlands Restoration Program
NC DENR DWQ

See Sheet 1A For Index of Sheets
See Sheet 1B For Conventional Plan Sheet Symbols



VICINITY MAP

90% PLANS SUBMITTAL

STATE OF NORTH CAROLINA
DIVISION OF HIGHWAYS
MACON COUNTY

LOCATION: US 441 (GEORGIA ROAD) FROM SR 1652 (WIDE HORIZON DR./SR IIS2 (BELDEN CIRCLE) TO US 64

TYPE OF WORK: GRADING, PAVING, DRAINAGE, CULVERT, AND SIGNALS

WETLAND AND SURFACE WATER IMPACTS PERMIT

PERMIT DRAWING
SHEET 1 OF 15

STATE PROJECT NUMBER	1
DATE	5/19/18
PROJECT NUMBER	R-5734A
DATE	5/19/18
DESIGNER	N.A.
DATE	5/19/18
CONTRACTOR	N.A.
DATE	5/19/18
CONTRACT	N.A.
DATE	5/19/18
CONTRACT	N.A.
DATE	5/19/18
CONTRACT	N.A.



NAD 832011

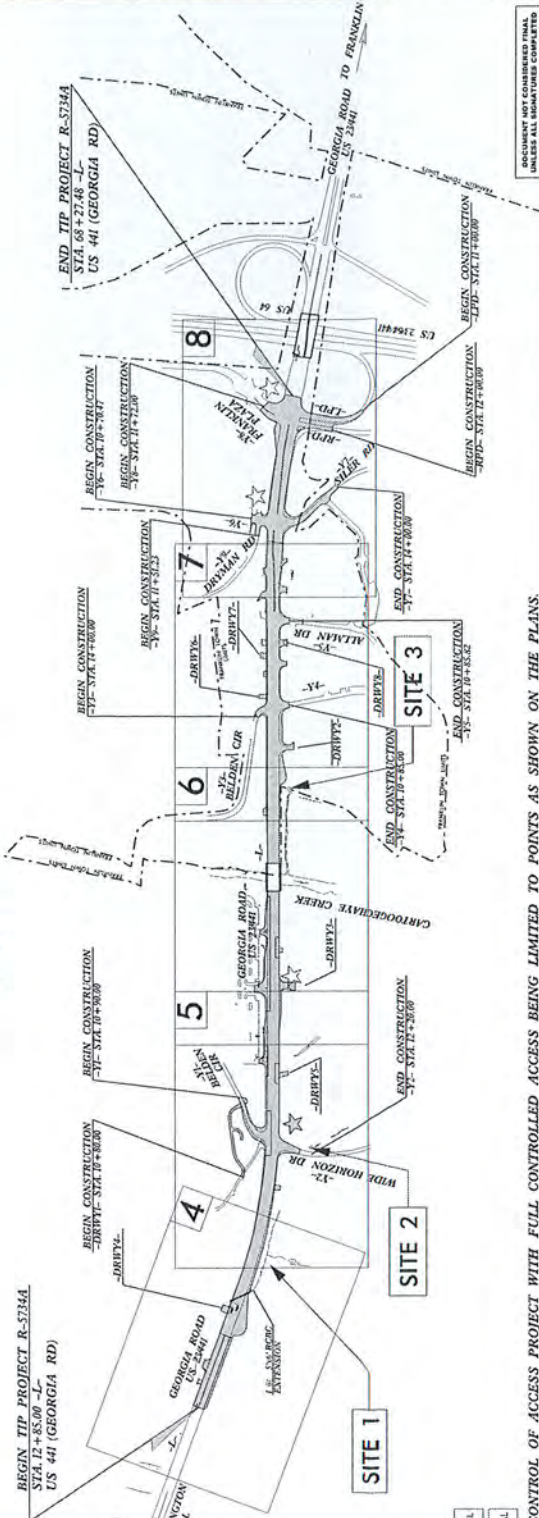

THIS IS A NO CONTROL OF ACCESS PROJECT WITH FULL CONTROLLED ACCESS BEING LIMITED TO POINTS AS SHOWN ON THE PLANS.

PROPOSED SIGNAL
UPGRADED SIGNAL

CONTRACT: TIP PROJECT: R-5734A

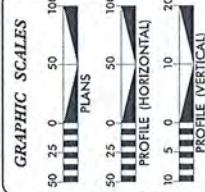

DESIGN DATA

ADT 2020	= 26,600
ADT 2040	= 34,200
K	= 8 %
D	= 55 %
T	= 7 %
V	= 45 MPH
* (TTT = 3% + DUALS 4%)	
FUNC CLASS = ARTERIAL	

PROJECT LENGTH

LENGTH ROADWAY TIP PROJECT R-5734A	= 1.021 MILES
TOTAL LENGTH TIP PROJECT R-5734A	= 1.021 MILES

Stantec
10000 North Carolina Department of Transportation
10000 North Carolina Department of Transportation
10000 North Carolina Department of Transportation
10000 North Carolina Department of Transportation

RIGHT OF WAY DATE: AUGUST 25, 2017
LETTING DATE: JUNE 19, 2018

HYDRAULICS ENGINEER: STEVE SMALLWOOD, P.E.
ROADWAY DESIGN ENGINEER: KENNETH MCDOWELL

STATE OF NORTH CAROLINA
DIVISION OF HIGHWAYS

PROJECT REFERENCE NO. R-5724	SHEET NO. 207
FORWARD DESIGN SHEET NO.	HYDRAULICS SHEET NO.
INCOMPLETE PLANS DO NOT USE FOR P.A. ACTIVATION	
DOCUMENT NOT CONSIDERED FINAL UNLESS ALL SIGNATURES COMPLETED PERMIT DRAWING SHEET 2 OF 15	

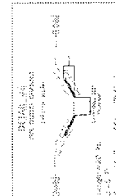
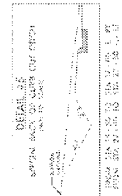
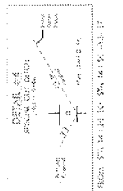
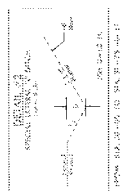
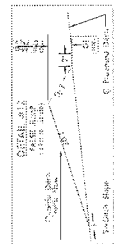
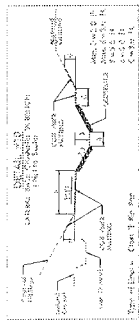
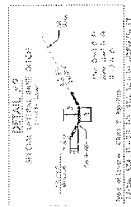
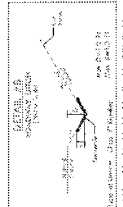
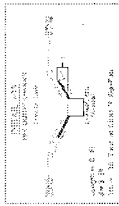

04/27/99

04/27/99

REVISIONS

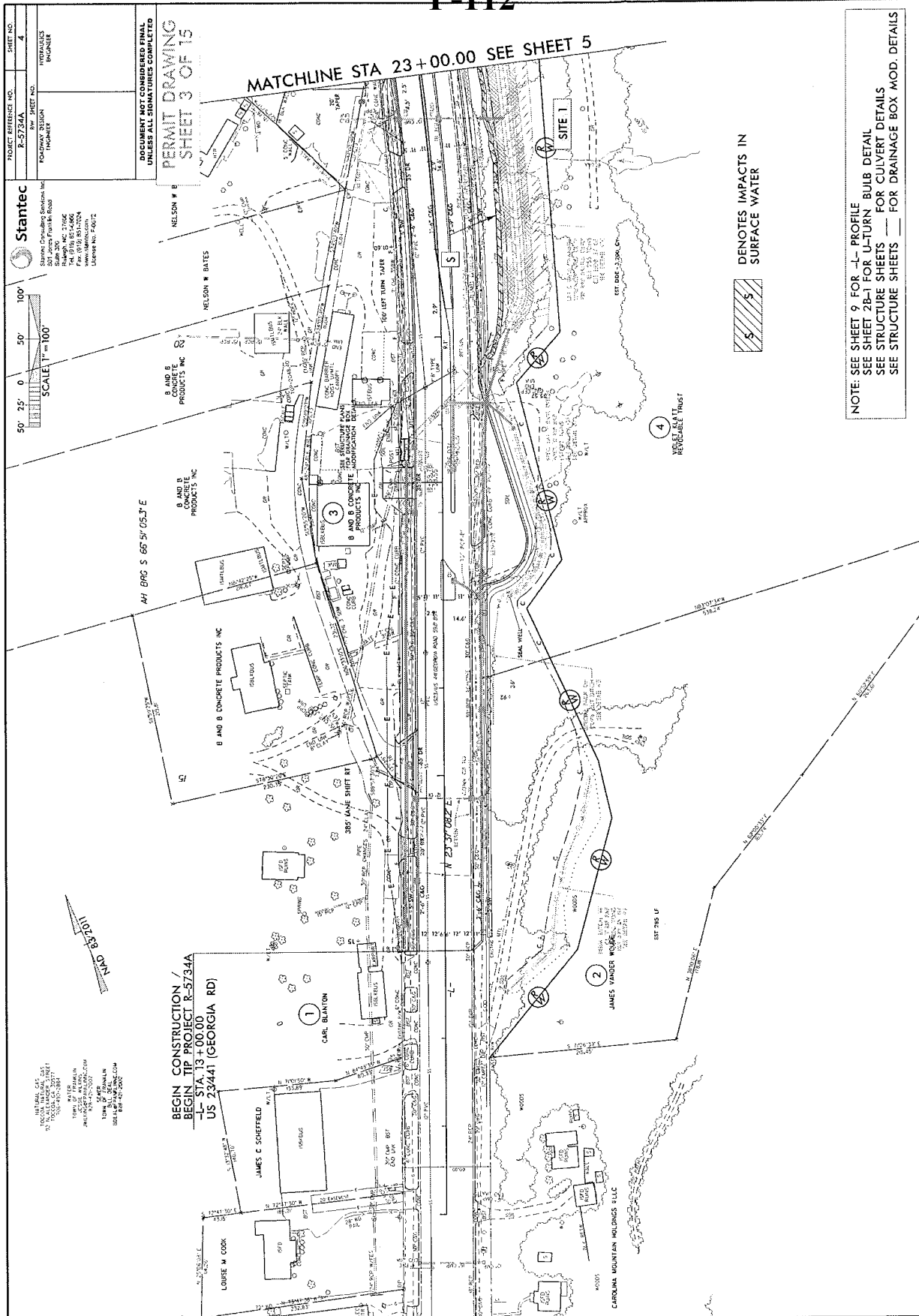

PROJECT REFERENCE NO. R-5734A	SHEET NO. 4
PROJECT LOCATION MOUNTAIN	DATE 11/15/2017
DESIGNER STANTEC	INTEGRITY REGISTERED PROFESSIONAL ENGINEER

Stantec
 3501 Peachtree Dunwoody Road
 Suite 300
 Atlanta, GA 30328
 Tel: (770) 412-2000
 Fax: (770) 412-2000
 License No. 54072

DOCUMENT NOT CONSIDERED FINAL
 UNLESS ALL SIGNATURES COMPLETED

PERMIT DRAWING
 SHEET 3 OF 15

SCALE 1" = 100'
 50' 75' 0' 100'

102.88' ON

AH BRG S 60°51'05.3"E

BEGIN CONSTRUCTION /
 TIP PROJECT R-5734A
 -L- STA. 13+00.00
 US 23441 (GEORGIA RD)

INTEGRITY
 REGISTERED PROFESSIONAL ENGINEER
 75 N. WALNUT STREET
 SUITE 300
 ATLANTA, GA 30303
 TEL: (404) 525-8881
 FAX: (404) 525-8881
 WWW.STANTEC.COM

DATE OF PLOTTING
 11/15/2017 10:00 AM
 PLOTTER
 HP PLOTTER
 PLOT SCALE
 1" = 100'
 USER
 J. SCHREFFIELD

REVISIONS

RW REVISION 1: REMOVED FUR FROM PARCELS 1,3, AND 5, NOTED NO CLAIM ON PARCEL 5 (R.2.2018)

RW REVISION 3: CHANGED NAME ON PARCELS 4 AND DEED BOOK ON PARCEL 3 (R.2.2018)

RW REVISION 5: ADDED TCE TO PARCELS 1,3, AND 10 (D.R.W.5 - ON PARCEL 10) (2017.09.21)

DATE: 11/15/2017 10:00 AM

PROJECT: R-5734A

DATE: 11/15/2017 10:00 AM

PROJECT: R-5734A

DATE: 11/15/2017 10:00 AM

NOTE: SEE SHEET 9 FOR -L- PROFILE
 SEE SHEET 2B-1 FOR U-TURN BULB DETAIL
 SEE STRUCTURE SHEETS FOR CULVERT DETAILS
 SEE STRUCTURE SHEETS FOR DRAINAGE BOX MOD. DETAILS

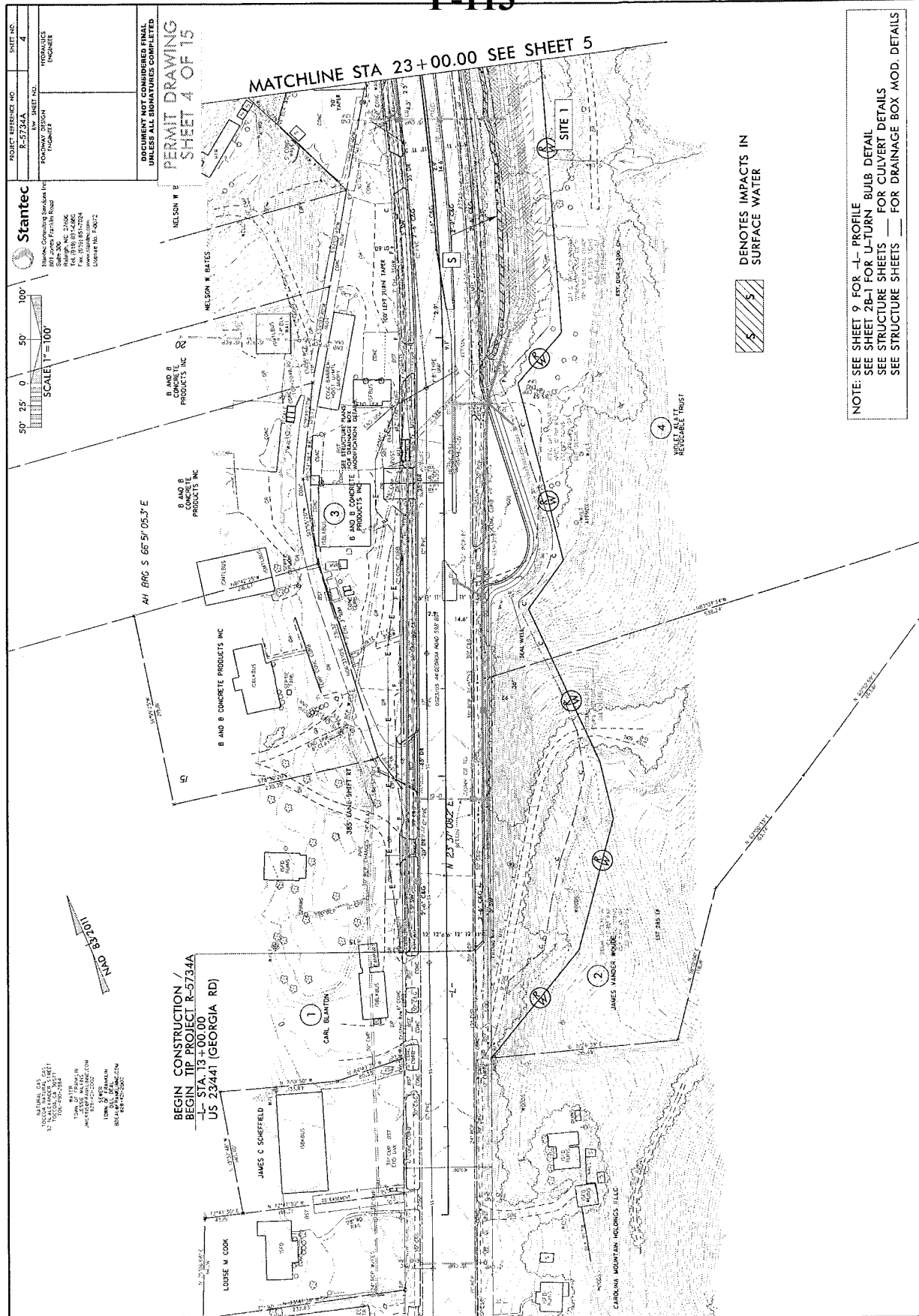

PROJECT REFERENCE NO.	R-5734A	SHEET NO.	4
FOUNDER REGION	INDIANAS	DATE	10/20/2018

Stantec
 Stantec Consulting Services Inc.
 1000 North Dearborn Street
 Suite 300
 Chicago, IL 60610
 Tel: (773) 851-4800
 Fax: (773) 851-7824
 License No. E-00172

DOCUMENT NOT CONSIDERED FINAL
 UNLESS ALL SIGNATURES COMPLETED

PERMIT DRAWING
 SHEET 4 OF 15



SCALE: 1" = 100'

BEGIN CONSTRUCTION /
 BEGIN TIP PROJECT R-5734A
 AT STA. 13+00.00
 US 23441 (GEORGIA RD)

NELSON & BATES
 B AND B CONCRETE PRODUCTS INC
 CARL BLANTON
 LOUISE M COOK
 JAMES C SCHEFFIELD
 JAMES MANDER MOORE
 CAROLINA MOUNTAIN HOLDINGS, LLC

REVISIONS

RW REVISION 1: REMOVED FUEL FROM PARCELS 1, 3, AND 5, NOTED NO CLUM ON PARCEL 5 ADDED TCE TO PARCELS 1, 3, AND 10 -DRWYS- ON PARCEL 10 [2017/09/12]
 REVISION 2: CHANGED NAME ON PARCEL 4 AND DEED BOOK ON PARCEL 3 (12/2018)
 REVISION 3: CHANGED NAME ON PARCEL 4 AND DEED BOOK ON PARCEL 3 (12/2018)

NOTE: SEE SHEET 9 FOR U-TURN PROFILE BULB DETAIL
 SEE SHEET 2B-1 FOR U-TURN BULB DETAIL
 SEE STRUCTURE SHEETS FOR CULVERT DETAILS
 SEE STRUCTURE SHEETS FOR DRAINAGE BOX MOD. DETAILS

100' BOUNDARY

100' BOUNDARY

100' BOUNDARY

100' BOUNDARY

PROJECT REFERENCE NO. P-2/34
 SHEET NO. 4D
 HYDRAULICS ENGINEER
 ROADWAY DESIGN ENGINEER
 INCOMPLETE PLANS DO NOT USE FOR CONSTRUCTION

DOCUMENT NOT CONSIDERED FINAL UNLESS ALL SIGNATURES COMPLETED

PERMIT DRAWING SHEET 5 OF 15

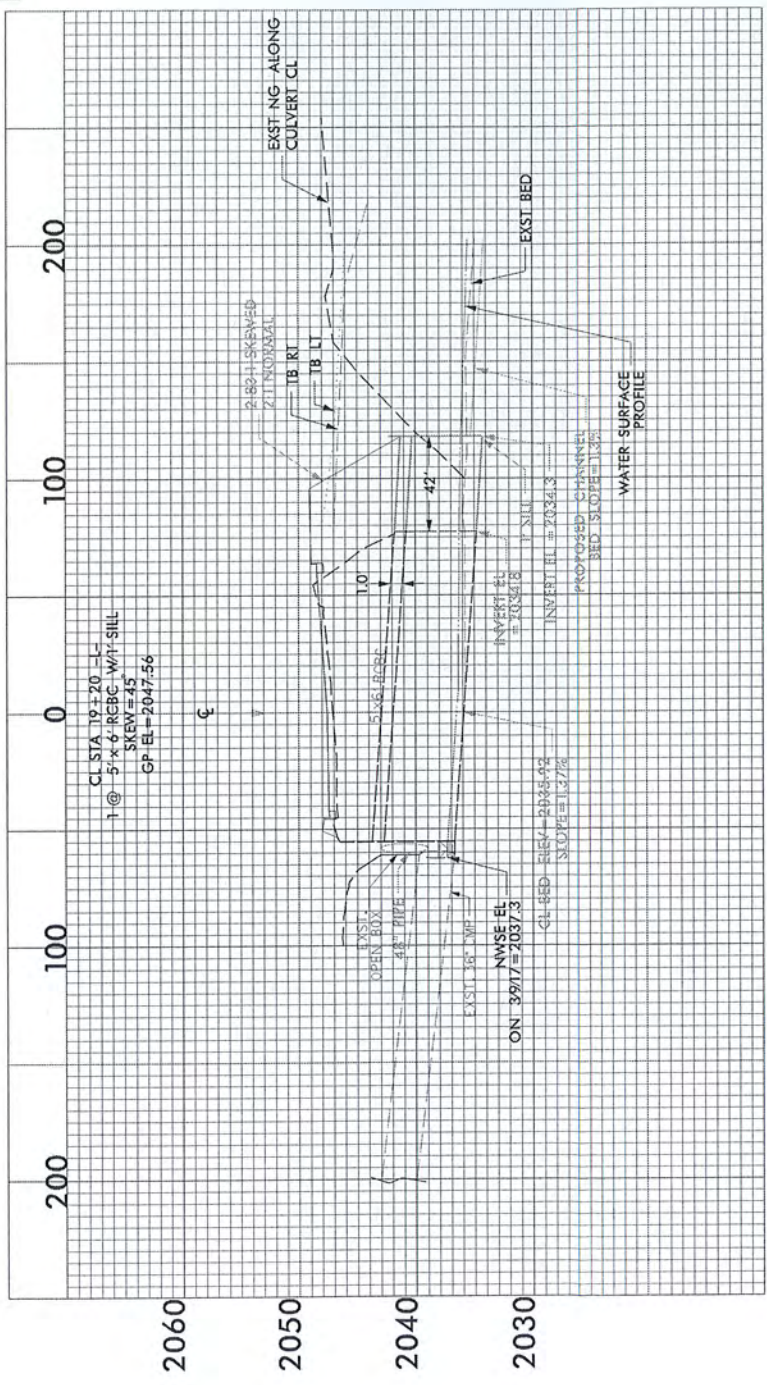

NO.	DATE	REVISIONS

1/2/2008
 2/2/2008
 3/2/2008
 4/2/2008
 5/2/2008
 6/2/2008
 7/2/2008
 8/2/2008
 9/2/2008
 10/2/2008
 11/2/2008
 12/2/2008

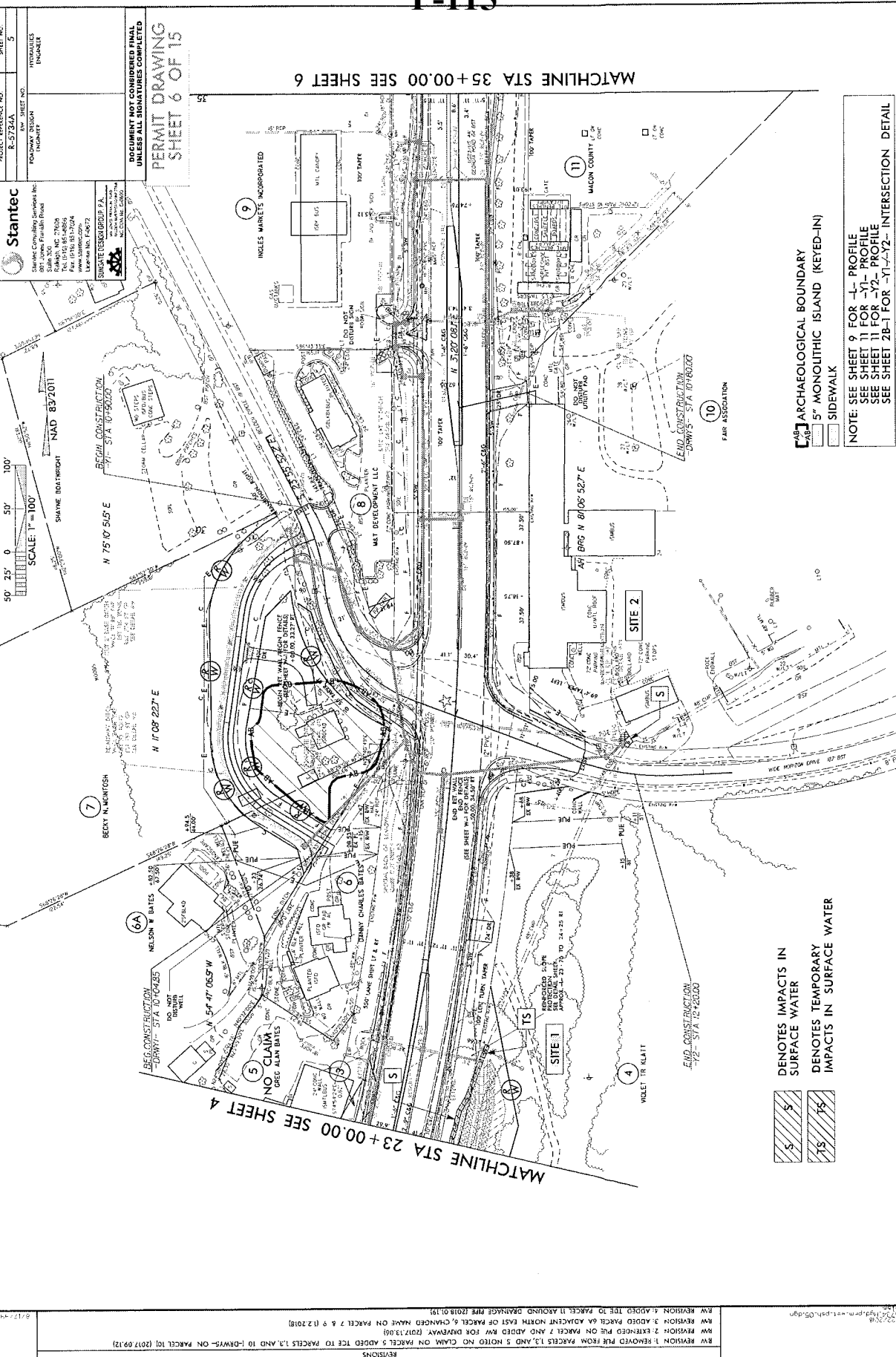

Stantec
Stantec Consulting Services Inc.
800 Lake Forest Road
Raleigh, NC 27608
Tel: 919 851 3200
Fax: 919 851 3204
www.stantec.com
License No. 146572

PROJECT REFERENCE NO. R-5734A
SHEET NO. 5
NATURALS DIVISION
ROADWAY DESIGN
TIDWENTY

**DOCUMENT NOT CONSIDERED FINAL
UNLESS ALL SIGNATURES COMPLETED**
PERMIT DRAWING
SHEET 6 OF 15

MATCHLINE STA 35+00.00 SEE SHEET 6

SCALE: 1" = 100'
SHAWNEE BOUNDARY NAD 83/2011

[AB] ARCHAEOLOGICAL BOUNDARY
[MI] MONOLITHIC ISLAND (KEYED-IN)
[SW] SIDEWALK

NOTE: SEE SHEET 9 FOR -Y1- PROFILE
SEE SHEET 11 FOR -Y1- PROFILE
SEE SHEET 11 FOR -Y2- PROFILE
SEE SHEET 2B-1 FOR -Y1-Y2- INTERSECTION DETAIL

[S] DENOTES IMPACTS IN SURFACE WATER
[TS] DENOTES TEMPORARY IMPACTS IN SURFACE WATER

- REVISIONS**
- REVISION 1: REMOVED PUE FROM PARCELS 1,3, AND 5 AND NO CLAIM ON PARCEL 5 ADDED TCE TO PARCELS 1,3 AND 10 -DWYS- ON PARCEL 10 (2017.09.12)
 - REVISION 2: EXTENDED PUE ON PARCEL 7 AND ADDED RW FOR DRYWYK (2017.13.08)
 - REVISION 3: ADDED PARCEL 6A ADJACENT NORTH EAST OF PARCEL 6, CHANGED MAKE ON PARCEL 7 & 9 (11.2.018)
 - REVISION 4: ADDED TCE TO PARCEL 11 AROUND DRAINAGE FIVE (2018.01.18)

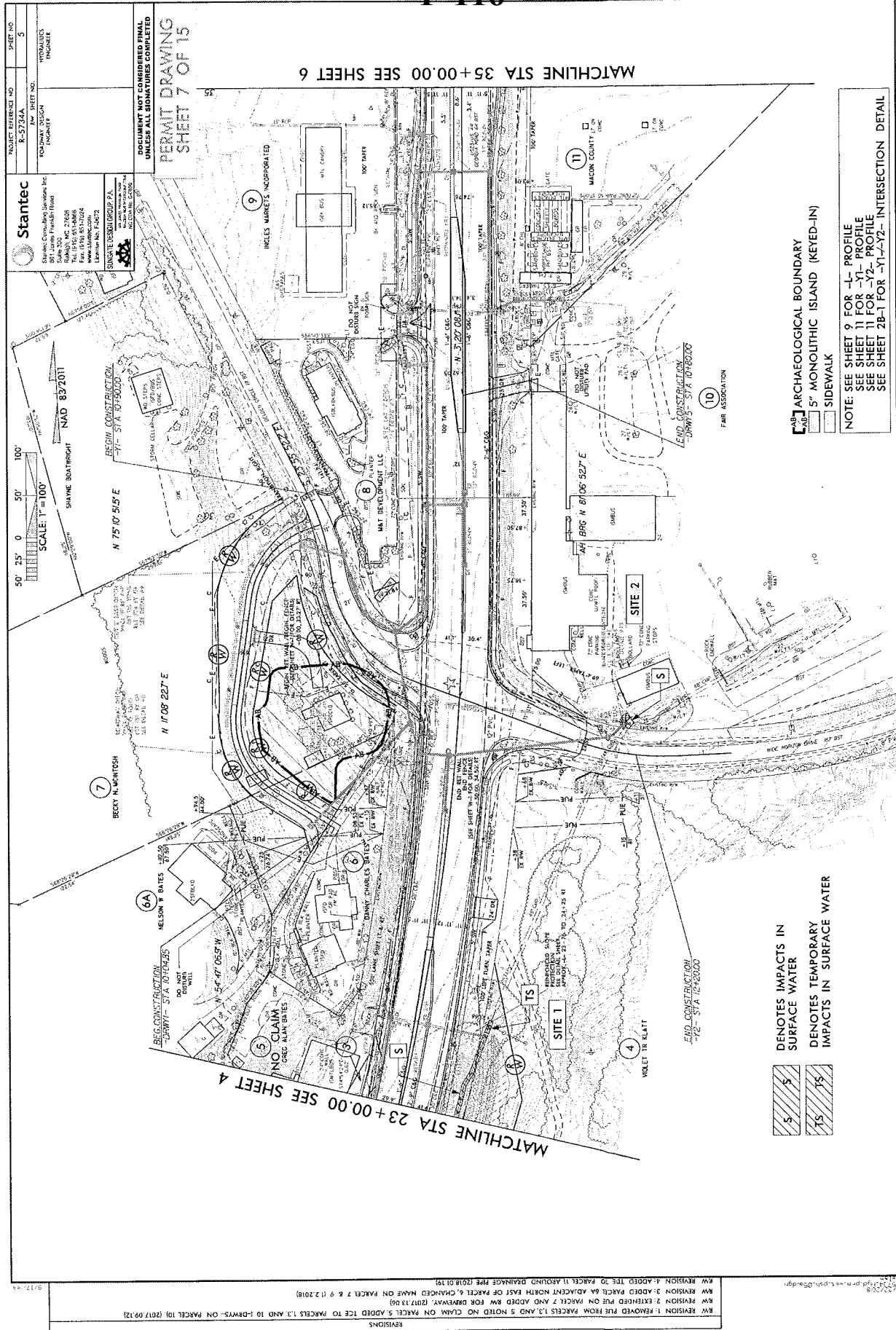

PROJECT REFERENCE NO.	E-5732A	SHEET NO.	5
PROJECT NAME	ROADWAY DESIGN	DATE	10/11/2017
ENGINEER	HYDRAULICS	PROJECT	ENGINEER

Stantec
 3700 Central Expressway, Suite 200
 Irvine, CA 92618
 Tel: (949) 251-1000
 Fax: (949) 251-1000
 License No. F-0072

DOCUMENT NOT CONSIDERED FINAL
 UNLESS ALL SUBMITTALS COMPLETED

PERMIT DRAWING
 SHEET 7 OF 15

SCALE: 1"=100'
 SHAWNEE BDA THROUGH NAD 83/2011

REG. CONSTRUCTION
 DRAWING STA 10+80.00
 -171- STA 10+80.00

REG. CONSTRUCTION
 DRAWING STA 10+80.00
 -171- STA 10+80.00

REG. CONSTRUCTION
 DRAWING STA 10+80.00
 -171- STA 10+80.00

REG. CONSTRUCTION
 DRAWING STA 10+80.00
 -171- STA 10+80.00

REG. CONSTRUCTION
 DRAWING STA 10+80.00
 -171- STA 10+80.00

REG. CONSTRUCTION
 DRAWING STA 10+80.00
 -171- STA 10+80.00

REG. CONSTRUCTION
 DRAWING STA 10+80.00
 -171- STA 10+80.00

REG. CONSTRUCTION
 DRAWING STA 10+80.00
 -171- STA 10+80.00

REG. CONSTRUCTION
 DRAWING STA 10+80.00
 -171- STA 10+80.00

REG. CONSTRUCTION
 DRAWING STA 10+80.00
 -171- STA 10+80.00

REG. CONSTRUCTION
 DRAWING STA 10+80.00
 -171- STA 10+80.00

REG. CONSTRUCTION
 DRAWING STA 10+80.00
 -171- STA 10+80.00

REG. CONSTRUCTION
 DRAWING STA 10+80.00
 -171- STA 10+80.00

MATCHLINE STA 23+00.00 SEE SHEET 4

MATCHLINE STA 35+00.00 SEE SHEET 6

MATCHLINE STA 23+00.00 SEE SHEET 4

MATCHLINE STA 35+00.00 SEE SHEET 6

MATCHLINE STA 23+00.00 SEE SHEET 4

MATCHLINE STA 35+00.00 SEE SHEET 6

MATCHLINE STA 23+00.00 SEE SHEET 4

MATCHLINE STA 35+00.00 SEE SHEET 6

MATCHLINE STA 23+00.00 SEE SHEET 4

MATCHLINE STA 23+00.00 SEE SHEET 4

MATCHLINE STA 35+00.00 SEE SHEET 6

MATCHLINE STA 23+00.00 SEE SHEET 4

MATCHLINE STA 35+00.00 SEE SHEET 6

MATCHLINE STA 23+00.00 SEE SHEET 4

MATCHLINE STA 35+00.00 SEE SHEET 6

MATCHLINE STA 23+00.00 SEE SHEET 4

MATCHLINE STA 35+00.00 SEE SHEET 6

MATCHLINE STA 23+00.00 SEE SHEET 4

MATCHLINE STA 23+00.00 SEE SHEET 4

MATCHLINE STA 35+00.00 SEE SHEET 6

MATCHLINE STA 23+00.00 SEE SHEET 4

MATCHLINE STA 35+00.00 SEE SHEET 6

MATCHLINE STA 23+00.00 SEE SHEET 4

MATCHLINE STA 35+00.00 SEE SHEET 6

MATCHLINE STA 23+00.00 SEE SHEET 4

MATCHLINE STA 35+00.00 SEE SHEET 6

MATCHLINE STA 23+00.00 SEE SHEET 4

MATCHLINE STA 23+00.00 SEE SHEET 4

MATCHLINE STA 35+00.00 SEE SHEET 6

MATCHLINE STA 23+00.00 SEE SHEET 4

MATCHLINE STA 35+00.00 SEE SHEET 6

MATCHLINE STA 23+00.00 SEE SHEET 4

MATCHLINE STA 35+00.00 SEE SHEET 6

MATCHLINE STA 23+00.00 SEE SHEET 4

MATCHLINE STA 35+00.00 SEE SHEET 6

MATCHLINE STA 23+00.00 SEE SHEET 4

MATCHLINE STA 23+00.00 SEE SHEET 4

MATCHLINE STA 35+00.00 SEE SHEET 6

MATCHLINE STA 23+00.00 SEE SHEET 4

MATCHLINE STA 35+00.00 SEE SHEET 6

MATCHLINE STA 23+00.00 SEE SHEET 4

MATCHLINE STA 35+00.00 SEE SHEET 6

MATCHLINE STA 23+00.00 SEE SHEET 4

MATCHLINE STA 35+00.00 SEE SHEET 6

MATCHLINE STA 23+00.00 SEE SHEET 4

MATCHLINE STA 23+00.00 SEE SHEET 4

MATCHLINE STA 35+00.00 SEE SHEET 6

MATCHLINE STA 23+00.00 SEE SHEET 4

MATCHLINE STA 35+00.00 SEE SHEET 6

MATCHLINE STA 23+00.00 SEE SHEET 4

MATCHLINE STA 35+00.00 SEE SHEET 6

MATCHLINE STA 23+00.00 SEE SHEET 4

MATCHLINE STA 35+00.00 SEE SHEET 6

MATCHLINE STA 23+00.00 SEE SHEET 4

REVISIONS

RW REVISION 1: REMOVED PUE FROM PARCELS 1,3, AND 5 NOTED NO CLAIM ON PARCEL 5. ADDED ICE TO PARCELS 1,3 AND 10 (P-RW5- ON PARCEL 10) (2017.09.12)

RW REVISION 2: EXTENDED PUE ON PARCEL 7 AND ADDED RW FOR DRIVEWAY. (2017.13.06)

RW REVISION 3: ADDED PARCEL 6A ADJACENT NORTH EAST OF PARCEL 5, CHANGED NAME ON PARCEL 7 & 8 (11.2.018)

RW REVISION 4: ADDED TFS TO PARCEL 11 AROUND DRAINAGE PIPE (2018.01.10)

5/17/18

MATCHLINE STA 23+00.00 SEE SHEET 4

MATCHLINE STA 35+00.00 SEE SHEET 6

MATCHLINE STA 23+00.00 SEE SHEET 4

MATCHLINE STA 35+00.00 SEE SHEET 6

MATCHLINE STA 23+00.00 SEE SHEET 4

MATCHLINE STA 35+00.00 SEE SHEET 6

MATCHLINE STA 23+00.00 SEE SHEET 4

MATCHLINE STA 35+00.00 SEE SHEET 6

MATCHLINE STA 23+00.00 SEE SHEET 4

MATCHLINE STA 23+00.00 SEE SHEET 4

MATCHLINE STA 23+00.00 SEE SHEET 4

MATCHLINE STA 35+00.00 SEE SHEET 6

MATCHLINE STA 23+00.00 SEE SHEET 4

MATCHLINE STA 35+00.00 SEE SHEET 6

MATCHLINE STA 23+00.00 SEE SHEET 4

MATCHLINE STA 35+00.00 SEE SHEET 6

MATCHLINE STA 23+00.00 SEE SHEET 4

MATCHLINE STA 35+00.00 SEE SHEET 6

MATCHLINE STA 23+00.00 SEE SHEET 4

MATCHLINE STA 23+00.00 SEE SHEET 4

MATCHLINE STA 23+00.00 SEE SHEET 4

MATCHLINE STA 35+00.00 SEE SHEET 6

MATCHLINE STA 23+00.00 SEE SHEET 4

MATCHLINE STA 35+00.00 SEE SHEET 6

MATCHLINE STA 23+00.00 SEE SHEET 4

MATCHLINE STA 35+00.00 SEE SHEET 6

MATCHLINE STA 23+00.00 SEE SHEET 4

MATCHLINE STA 35+00.00 SEE SHEET 6

MATCHLINE STA 23+00.00 SEE SHEET 4

MATCHLINE STA 23+00.00 SEE SHEET 4

MATCHLINE STA 23+00.00 SEE SHEET 4

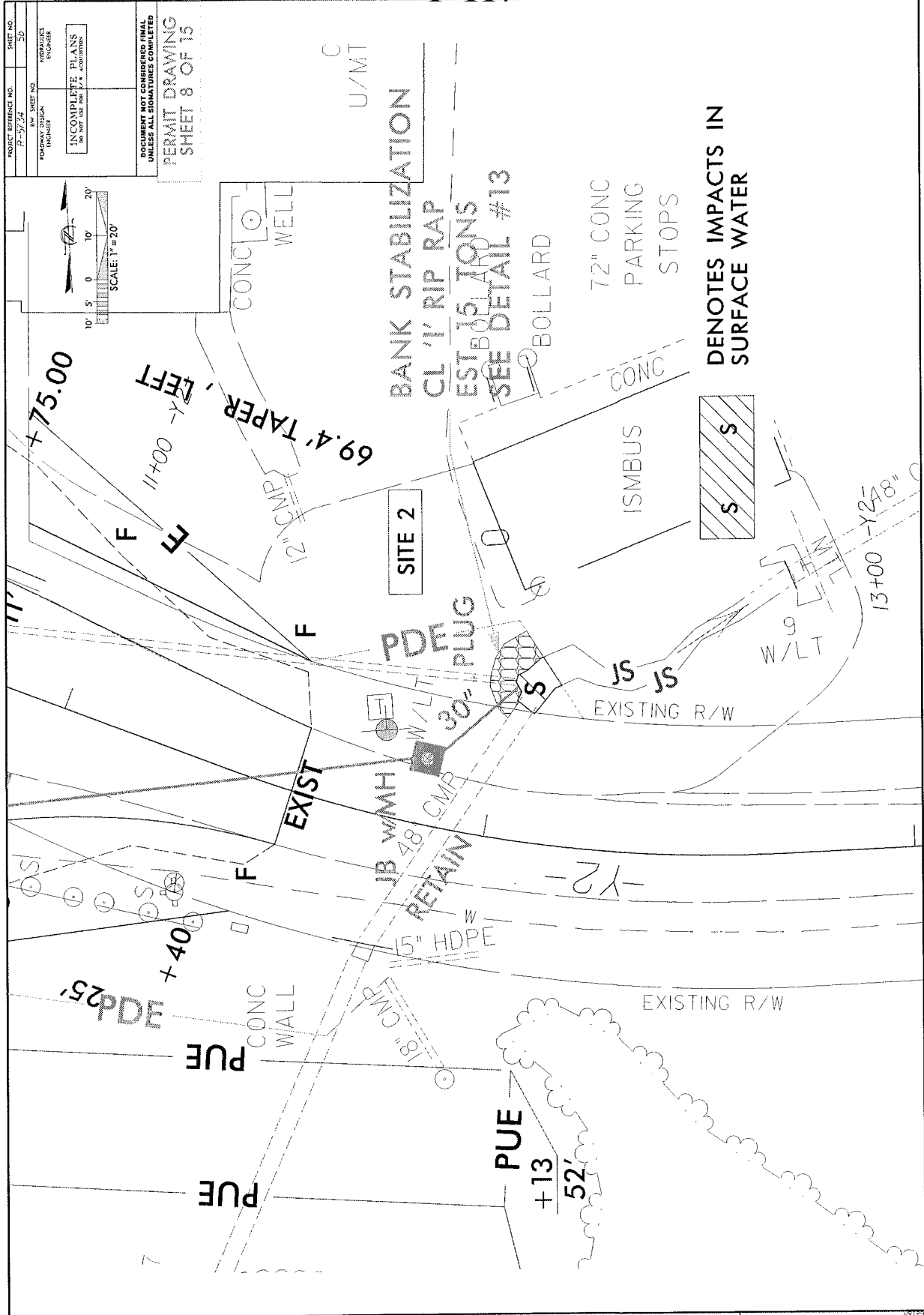

PROJECT REFERENCE NO. P-5734
 SHEET NO. 50
 DWG. SHEET NO. 50
 PROFESSIONAL ENGINEER
 INCOMPLETE PLANS
 DO NOT USE FOR CONSTRUCTION
 DOCUMENT NOT CONSIDERED FINAL
 UNLESS ALL SIGNATURES COMPLETED
 PERMIT DRAWING
 SHEET 8 OF 15

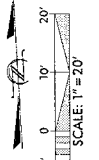

REVISIONS

DENOTES IMPACTS IN SURFACE WATER

BANK STABILIZATION
CL '1' RIP RAP
EST. 15 TONS
SEE DETAIL #13

72" CONC
PARKING
STOPS

ISMBUS

EXISTING R/W

EXISTING R/W

C
U/M/T

SITE 2

PDE
30" PLUG

RETAIN

15" HDPE

18" CMP

48" CMP

W/LT

EXIST

12" CMP

CONC
WELL

69.4' TAPER, LEFT

+75.00

11+00

+40.00

EDD25'

+13
52'

9 W/LT

13+00

-Y2A8"

JS JS



NO.	DATE	DESCRIPTION

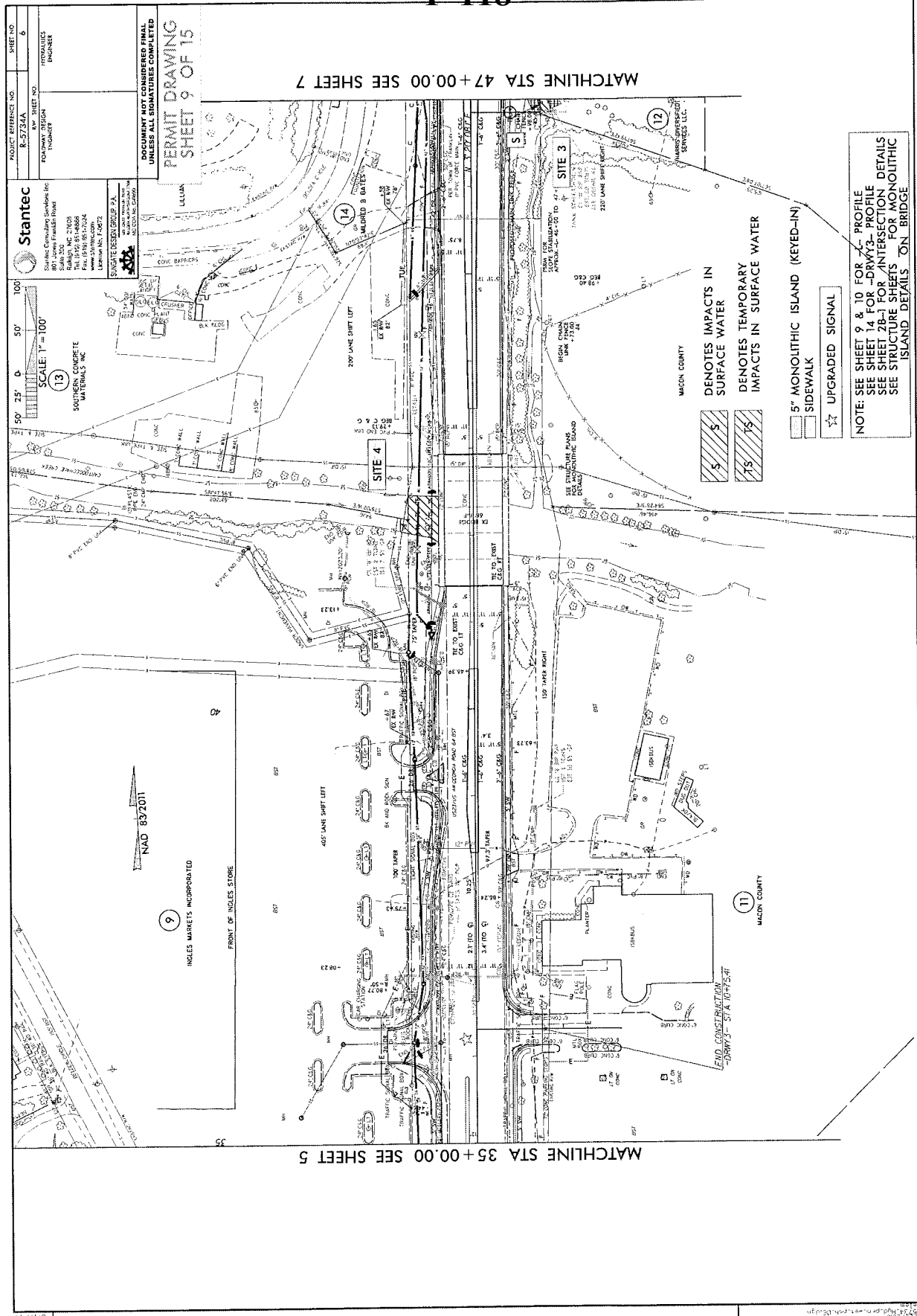

REVISIONS

RW REVISION 3: CHANGED NAME ON PARCEL 9 (1/2 2018)
 RW REVISION 4: CONVERT EXISTING ROW TO CA ON PARCEL 12 (2018.01.19)

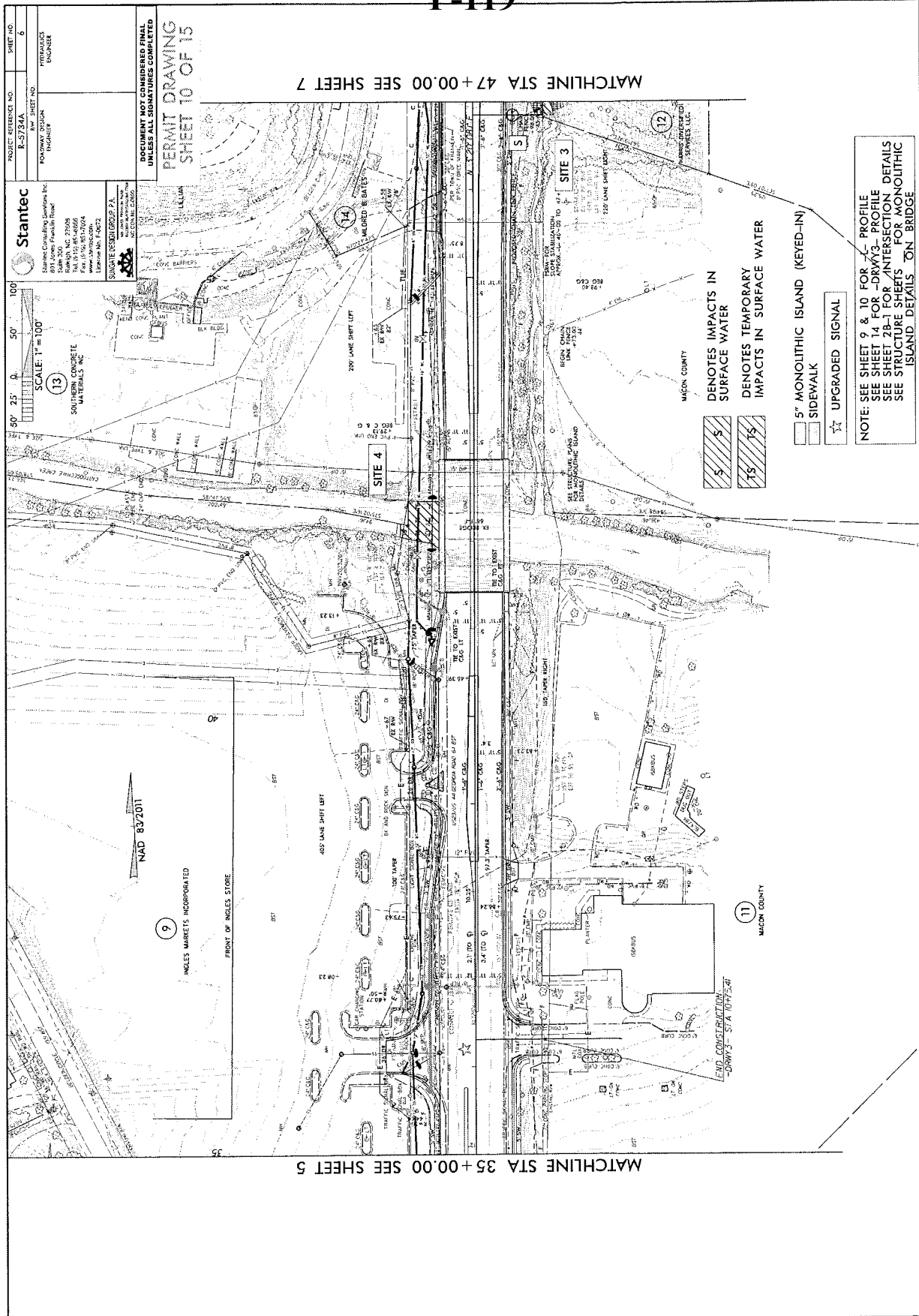

PROJECT REFERENCE NO. E-2734A
 RW SHEET NO. 6
 PROJECT LOCATION: RICHMOND COUNTY, GEORGIA

Stantec
 Stantec Consulting Services, Inc.
 1000 Peachtree Street, NE
 Suite 200
 Atlanta, GA 30309
 Phone: 404.851.7094
 Fax: 404.851.7094
 Email: info@stantec.com

SCALE: 1" = 100'
 30' 25' 0' 50' 100'

DOCUMENT NOT CONSIDERED FINAL
 UNLESS ALL SIGNATURES COMPLETED
 PERMIT DRAWING
 SHEET 10 OF 15

MATCHLINE STA 47+00.00 SEE SHEET 7

MATCHLINE STA 35+00.00 SEE SHEET 5

5' MONOLITHIC ISLAND (KEYED-IN)
 SIDEWALK
 UPGRADED SIGNAL

5' MONOLITHIC ISLAND (KEYED-IN)
 SIDEWALK
 UPGRADED SIGNAL

NOTE: SEE SHEET 9 & 10 FOR -L- PROFILE
 SEE SHEET 14 FOR -DRWY3- PROFILE
 SEE SHEET 2B-1 FOR INTERSECTION DETAILS
 SEE STRUCTURE SHEETS FOR MONOLITHIC ISLAND DETAILS ON BRIDGE

REVISIONS
 RW REVISION 4: CONVERT EXISTING ROW TO CA ON PARCEL 12 (2018.01.19)
 RW REVISION 3: CHANGED NAME ON PARCEL 9 (12.2018)
 12/27/2018
 12/27/2018
 12/27/2018

PROJECT TYPICAL DETAILS

COFFER DAM CONSTRUCTION NOTES:

1. MATERIAL FROM THE STREAM BED WILL NOT BE USED FOR THE COFFER DAM.
2. NO EARTHEN MATERIAL WILL BE USED FOR THE COFFER DAM OR PLACED IN THE STREAM FOR ANY REASON.
3. DISTURBANCE OF THE STREAM BED IS TO BE LIMITED TO THE CONSTRUCTION OF THE WATER LINE WORK AND RESTORED TO ORIGINAL CONTOURS WHEN WORK IS COMPLETED.
4. COFFER DAM MATERIAL IS TO BE APPROVED BY ENGINEER.

PHASE 1

1. CONSTRUCT COFFER DAM TO CENTERLINE OF STREAM. ONE-HALF (1/2) OF THE STREAM CHANNEL IS TO BE OPEN AT ALL TIMES.
2. NO FERTILIZER TO BE USED IN THIS AREA.
3. INSTALL REMAINING PROPOSED WATER LINE.
4. CONTAMINATION TO THE STREAM FROM WORK TO BE AVOIDED.
5. REMOVE COFFER DAM.

PHASE 2

1. CONSTRUCT COFFER DAM TO ENCOMPASS END OF WATER LINE CONSTRUCTED IN PHASE 1. ONE-HALF (1/2) OF THE STREAM CHANNEL IS TO BE OPEN AT ALL TIMES.
2. NO FERTILIZER TO BE USED IN THIS AREA.
3. INSTALL REMAINING PROPOSED WATER LINE.
4. CONTAMINATION TO THE STREAM FROM WORK TO BE AVOIDED.
5. REMOVE COFFER DAM.

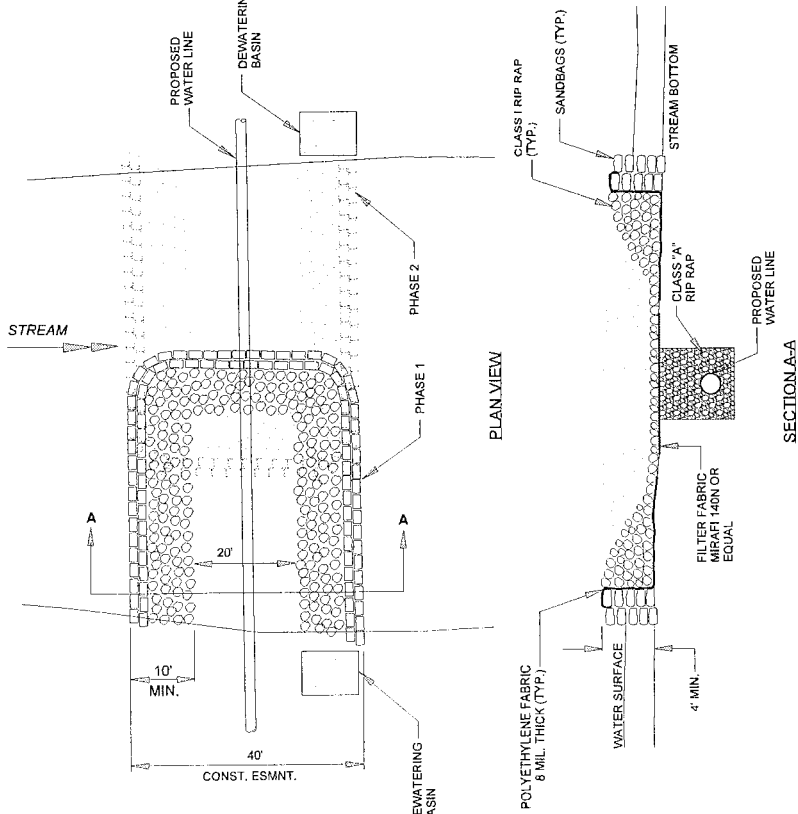

COFFER DAM DETAIL

PERMIT DRAWING
SHEET 11 OF 15

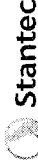

Stantec Consulting Services Inc.
1000 Franklin Road
Suite 300
Raleigh, NC 27606
Tel. (919) 851-6868
Fax. (919) 851-7024
www.stantec.com
License No. F-0872

PROJECT REFERENCE NO.	UC-03F
DESIGNED BY: MCM	UC-03F
DRAWN BY: RGR	
CHECKED BY: MCM	
APPROVED BY:	
REVISED:	
DATE:	
DESCRIPTION:	
PROJECT LOCATION:	
DATE OF PROJECT:	
PROJECT NO.:	
DATE OF ISSUE:	
DATE OF REVISION:	
DATE OF CLOSURE:	
DATE OF COMPLETION:	
DATE OF AS-BUILT:	
DATE OF FINAL:	
DATE OF ARCHIVE:	
DATE OF DELETED:	
DATE OF REVISION:	
DATE OF CLOSURE:	
DATE OF COMPLETION:	
DATE OF AS-BUILT:	
DATE OF FINAL:	
DATE OF ARCHIVE:	
DATE OF DELETED:	

UTILITY CONSTRUCTION

INCOMPLETE PLANS
DO NOT USE FOR P.P.S. ACQUISITION

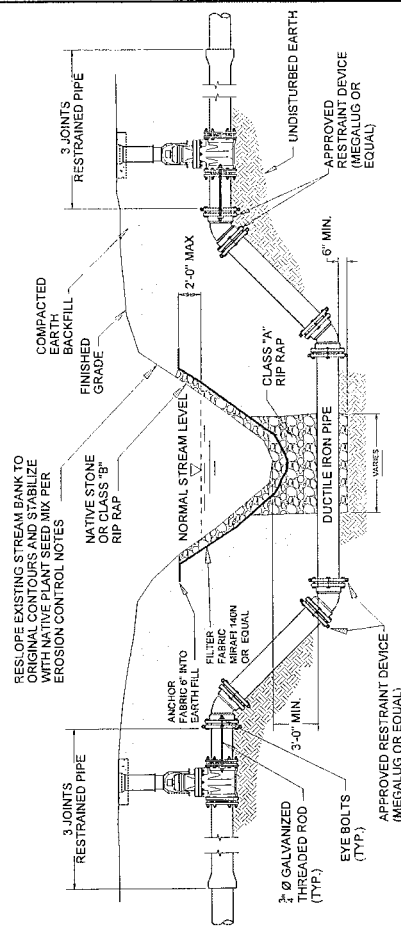

- WATER LINE CREEK CROSSING NOTES:**
1. CONTRACTOR WILL RESTRAIN 3 JOINTS PAST THE LAST FITTING AT THE TOP OF THE BANK AS SPECIFIED BY THE TOWN OF FRANKLIN.
 2. APPROVED RESTRAINING DEVICES INCLUDE RESTRAINING GLANDS (MEGALUGS), SPLIT LOCK AND PIN AND PIN AND WEDGE SYSTEMS. ALL RESTRAINING DEVICES MUST BE PROVIDED BY APPROVED PIPE MANUFACTURERS.
 3. SEE TRENCH DETAIL FOR ACTUAL TRENCH WIDTH.
 4. NO FERTILIZER TO BE USED WITHIN 10'-0" OF STREAM BANK.

WATER LINE CREEK CROSSING DETAIL

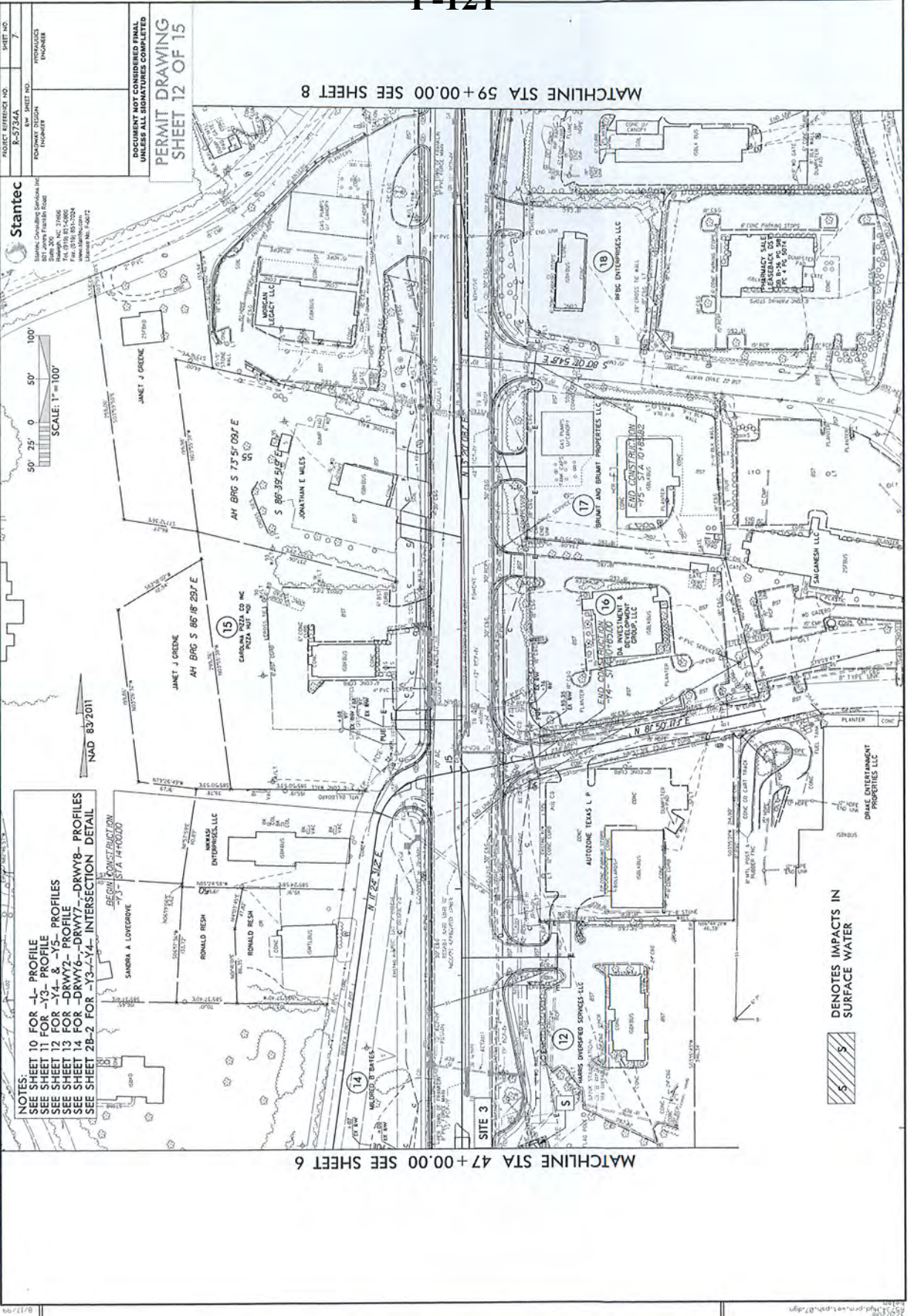

PROJECT REFERENCE NO. R-2736A
 SHEET NO. 7
 ROADWAY DESIGN ENGINEER
 HYDRAULIC ENGINEER

Stantec
 Stantec Consulting Services Inc.
 801 Jones Franklin Road
 Raleigh, NC 27606
 Tel: (919) 881-0000
 Fax: (919) 881-0000
 www.stantec.com
 License No. 74807

CONSTRUCTION NOT COMMENCED UNTIL
 UNLESS ALL REQUIREMENTS COMPLETED
PERMIT DRAWING
SHEET 12 OF 15

MATCHLINE STA 59+00.00 SEE SHEET 8

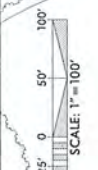

NAD 83 2011

NOTES:
 SEE SHEET 10 FOR -L- PROFILE
 SEE SHEET 11 FOR -Y3- PROFILE
 SEE SHEET 12 FOR -Y4- & -Y5- PROFILE
 SEE SHEET 13 FOR -DRWY2- PROFILE
 SEE SHEET 14 FOR -DRWY6- & -DRWY7- PROFILE
 SEE SHEET 28-2 FOR -Y3-Y4- INTERSECTION DETAIL

MATCHLINE STA 47+00.00 SEE SHEET 6

DENOTES IMPACTS IN SURFACE WATER

REV. 55 REVISION 1 ADJUSTED 55 AT E STA 48+50 TO 48+50 TO 21; REMOVED PUE AND EASEMENT ON PARCEL 14; CHANGED NAME ON PARCEL 12 (2/2018)
 REVISIONS

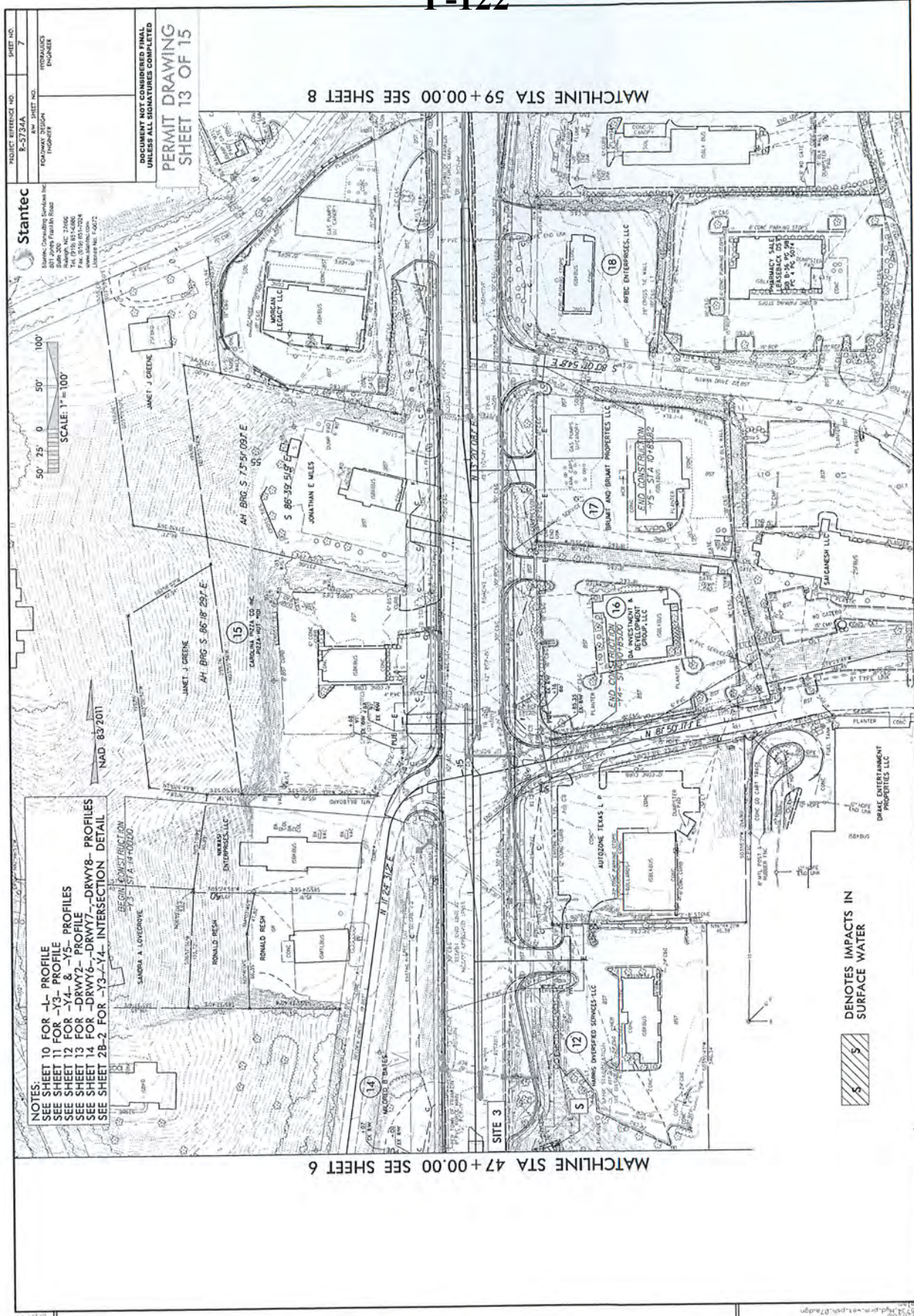

REV. 55 REVISION 1, ADJUSTED SS AT STA 49+00 TO 48+50 TO 48+50 TO 48+50 TO 21, REMOVED PUE AND EASEMENT ON PARCEL 14, CHANGED NAME ON PARCEL 12, (12.2018)

REVISIONS

6/17/19

WETLAND AND SURFACE WATER IMPACTS SUMMARY														
Site No.	Station (From/To)	Structure Size / Type	WETLAND IMPACTS				SURFACE WATER IMPACTS							
			Permanent Fill In Wetlands (ac)	Temp. Fill In Wetlands (ac)	Excavation in Wetlands (ac)	Mechanized Clearing in Wetlands (ac)	Hand Clearing in Wetlands (ac)	Permanent SW impacts (ac)	Temp. SW impacts (ac)	Existing Channel Impacts Permanent (ft)	Existing Channel Impacts Temp. (ft)	Natural Stream Design (ft)		
1	19+74 to 24+31 -L- RT	ROADWAY FILL							0.05	< 0.01	443	456	15	
2	10+02 TO 12+14 -Y2- LT	BANK STABILIZATION							< 0.01		10			
3	46+85 to 47+07 -L- RT	BANK STABILIZATION							< 0.01		20			
4	41+92 to 42+47 -L- LT	UTILITY CONSTRUCTION								0.04		44		
TOTALS*									0.06	0.04	473	59	0	

*Rounded totals are sum of actual impacts

NOTES:

- Site 1: Temporary Surface Water Impacts = 75 SF
- Site 2: Permanent Surface Water Impacts = 74 SF
- Site 3: Permanent Surface Water Impacts = 230 SF
- Site 4: Temporary Surface Water Impacts = 1787 SF

Revised 2016 09 09

NC DEPARTMENT OF TRANSPORTATION
 DIVISION OF HIGHWAYS
 3-21-18
 MACON COUNTY
 R-5734A
 50192.1.1
 SHEET 15 OF 15

County : Macon

Line #	Item Number	Sec #	Description	Quantity	Unit Cost	Amount
ROADWAY ITEMS						
0001	0000100000-N	800	MOBILIZATION	Lump Sum	L.S.	
0002	0000400000-N	801	CONSTRUCTION SURVEYING	Lump Sum	L.S.	
0003	0015000000-N	205	SEALING ABANDONED WELLS	1 EA		
0004	0030000000-N	SP	TYPE II MODIFIED APPROACH FILL, STATION ***** (14+94.00 -L-)	Lump Sum	L.S.	
0005	0043000000-N	226	GRADING	Lump Sum	L.S.	
0006	0050000000-E	226	SUPPLEMENTARY CLEARING & GRUB- BING	2 ACR		
0007	0057000000-E	226	UNDERCUT EXCAVATION	1,050 CY		
0008	0134000000-E	240	DRAINAGE DITCH EXCAVATION	3,630 CY		
0009	0195000000-E	265	SELECT GRANULAR MATERIAL	3,300 CY		
0010	0196000000-E	270	GEOTEXTILE FOR SOIL STABILIZA- TION	3,500 SY		
0011	0199000000-E	SP	TEMPORARY SHORING	200 SF		
0012	0223000000-E	275	ROCK PLATING	200 SY		
0013	0225000000-E	SP	REINFORCED SOIL SLOPES	130 SY		
0014	0318000000-E	300	FOUNDATION CONDITIONING MATE- RIAL, MINOR STRUCTURES	1,441 TON		
0015	0320000000-E	300	FOUNDATION CONDITIONING GEO- TEXTILE	5,114 SY		
0016	0335200000-E	305	15" DRAINAGE PIPE	248 LF		
0017	0335400000-E	305	24" DRAINAGE PIPE	28 LF		
0018	0335500000-E	305	30" DRAINAGE PIPE	112 LF		
0019	0335850000-E	305	*** DRAINAGE PIPE ELBOWS (15")	2 EA		

County : Macon

Line #	Item Number	Sec #	Description	Quantity	Unit Cost	Amount
0020	0366000000-E	310	15" RC PIPE CULVERTS, CLASS III	396	LF	
0021	0372000000-E	310	18" RC PIPE CULVERTS, CLASS III	400	LF	
0022	0378000000-E	310	24" RC PIPE CULVERTS, CLASS III	40	LF	
0023	0390000000-E	310	36" RC PIPE CULVERTS, CLASS III	88	LF	
0024	0402000000-E	310	48" RC PIPE CULVERTS, CLASS III	608	LF	
0025	0448000000-E	310	***** RC PIPE CULVERTS, CLASS IV (48")	92	LF	
0026	0448200000-E	310	15" RC PIPE CULVERTS, CLASS IV	2,528	LF	
0027	0448300000-E	310	18" RC PIPE CULVERTS, CLASS IV	376	LF	
0028	0448400000-E	310	24" RC PIPE CULVERTS, CLASS IV	304	LF	
0029	0448500000-E	310	30" RC PIPE CULVERTS, CLASS IV	544	LF	
0030	0448600000-E	310	36" RC PIPE CULVERTS, CLASS IV	836	LF	
0031	0448700000-E	310	42" RC PIPE CULVERTS, CLASS IV	388	LF	
0032	0588000000-E	310	18" CS PIPE CULVERTS, 0.064" THICK	36	LF	
0033	0594000000-E	310	24" CS PIPE CULVERTS, 0.064" THICK	12	LF	
0034	0636000000-E	310	*** CS PIPE ELBOWS, ***** THICK (18", 0.064")	1	EA	
0035	0986000000-E	SP	GENERIC PIPE ITEM 15" CURED IN PLACE PIPE	106	LF	
0036	0986000000-E	SP	GENERIC PIPE ITEM 18" CURED IN PLACE PIPE	255	LF	

County : Macon

Line #	Item Number	Sec #	Description	Quantity	Unit Cost	Amount
0037	0986000000-E	SP	GENERIC PIPE ITEM 24" CURED IN PLACE PIPE	155 LF		
0038	0986000000-E	SP	GENERIC PIPE ITEM 30" CURED IN PLACE PIPE	185 LF		
0039	0995000000-E	340	PIPE REMOVAL	1,746 LF		
0040	1099500000-E	505	SHALLOW UNDERCUT	150 CY		
0041	1099700000-E	505	CLASS IV SUBGRADE STABILIZATION	250 TON		
0042	1121000000-E	520	AGGREGATE BASE COURSE	516 TON		
0043	1220000000-E	545	INCIDENTAL STONE BASE	2,050 TON		
0044	1275000000-E	600	PRIME COAT	175 GAL		
0045	1297000000-E	607	MILLING ASPHALT PAVEMENT, **** DEPTH (1-1/2")	2,590 SY		
0046	1330000000-E	607	INCIDENTAL MILLING	5,100 SY		
0047	1491000000-E	610	ASPHALT CONC BASE COURSE, TYPE B25.0C	7,050 TON		
0048	1503000000-E	610	ASPHALT CONC INTERMEDIATE COURSE, TYPE I19.0C	4,810 TON		
0049	1523000000-E	610	ASPHALT CONC SURFACE COURSE, TYPE S9.5C	9,610 TON		
0050	1575000000-E	620	ASPHALT BINDER FOR PLANT MIX	1,130 TON		
0051	1693000000-E	654	ASPHALT PLANT MIX, PAVEMENT REPAIR	200 TON		
0052	2022000000-E	815	SUBDRAIN EXCAVATION	67.2 CY		
0053	2026000000-E	815	GEOTEXTILE FOR SUBSURFACE DRAINS	200 SY		
0054	2036000000-E	815	SUBDRAIN COARSE AGGREGATE	33.6 CY		

County : Macon

Line #	Item Number	Sec #	Description	Quantity	Unit Cost	Amount
0055	2044000000-E	815	6" PERFORATED SUBDRAIN PIPE	200	LF	
0056	2070000000-N	815	SUBDRAIN PIPE OUTLET	1	EA	
0057	2077000000-E	815	6" OUTLET PIPE	6	LF	
0058	2253000000-E	840	PIPE COLLARS	3.148	CY	
0059	2264000000-E	840	PIPE PLUGS	0.13	CY	
0060	2275000000-E	SP	FLOWABLE FILL	52	CY	
0061	2286000000-N	840	MASONRY DRAINAGE STRUCTURES	101	EA	
0062	2308000000-E	840	MASONRY DRAINAGE STRUCTURES	61.1	LF	
0063	2364000000-N	840	FRAME WITH TWO GRATES, STD 840.16	25	EA	
0064	2366000000-N	840	FRAME WITH TWO GRATES, STD 840.24	8	EA	
0065	2367000000-N	840	FRAME WITH TWO GRATES, STD 840.29	4	EA	
0066	2374000000-N	840	FRAME WITH GRATE & HOOD, STD 840.03, TYPE ** (E)	10	EA	
0067	2374000000-N	840	FRAME WITH GRATE & HOOD, STD 840.03, TYPE ** (F)	16	EA	
0068	2374000000-N	840	FRAME WITH GRATE & HOOD, STD 840.03, TYPE ** (G)	25	EA	
0069	2396000000-N	840	FRAME WITH COVER, STD 840.54	18	EA	
0070	2451000000-N	852	CONCRETE TRANSITIONAL SECTION FOR DROP INLET	22	EA	
0071	2538000000-E	846	***-*** CONCRETE CURB & GUTTER (2'-9")	460	LF	
0072	2542000000-E	846	1'-6" CONCRETE CURB & GUTTER	2,800	LF	

County : Macon

Line #	Item Number	Sec #	Description	Quantity	Unit Cost	Amount
0073	2549000000-E	846	2'-6" CONCRETE CURB & GUTTER	11,560		LF
0074	2556000000-E	846	SHOULDER BERM GUTTER	48		LF
0075	2570000000-N	SP	MODIFIED CONCRETE FLUME	1		EA
0076	2591000000-E	848	4" CONCRETE SIDEWALK	4,600		SY
0077	2605000000-N	848	CONCRETE CURB RAMPS	39		EA
0078	2612000000-E	848	6" CONCRETE DRIVEWAY	714		SY
0079	2619000000-E	850	4" CONCRETE PAVED DITCH	50		SY
0080	2655000000-E	852	5" MONOLITHIC CONCRETE ISLANDS (KEYED IN)	1,600		SY
0081	2657000000-E	852	*** MONOLITHIC CONCRETE MEDIAN (*****) (5-1/2", KEYED IN)	20		SY
0082	2738000000-E	SP	GENERIC PAVING ITEM REINFORCED CONCRETE DRIVEWAY	259		SY
0083	2761000000-E	848	GENERIC PAVING ITEM 8" CONCRETE DRIVEWAY	90		SY
0084	2800000000-N	858	ADJUSTMENT OF CATCH BASINS	10		EA
0085	2830000000-N	858	ADJUSTMENT OF MANHOLES	4		EA
0086	2845000000-N	858	ADJUSTMENT OF METER BOXES OR VALVE BOXES	7		EA
0087	2860000000-N	859	CONVERT EXISTING CATCH BASIN TO JUNCTION BOX	1		EA
0088	2905000000-N	859	CONVERT EXISTING DROP INLET TO JUNCTION BOX	2		EA
0089	2995000000-N	SP	GENERIC DRAINAGE ITEM CONVERT EXISTING CATCH BASIN TO TRAFFIC BEARING JUNCTION BOX	2		EA
0090	3030000000-E	862	STEEL BEAM GUARDRAIL	2,000		LF

County : Macon

Line #	Item Number	Sec #	Description	Quantity	Unit Cost	Amount
0091	3045000000-E	862	STEEL BEAM GUARDRAIL, SHOP CURVED	112.5	LF	
0092	3150000000-N	862	ADDITIONAL GUARDRAIL POSTS	15	EA	
0093	3195000000-N	862	GUARDRAIL END UNITS, TYPE AT-1	1	EA	
0094	3210000000-N	862	GUARDRAIL END UNITS, TYPE CAT-1	6	EA	
0095	3215000000-N	SP	GUARDRAIL ANCHOR UNITS, TYPE III	7	EA	
0096	3287000000-N	SP	GUARDRAIL END UNITS, TYPE TL-3	6	EA	
0097	3288000000-N	SP	GUARDRAIL END UNITS, TYPE TL-2	4	EA	
0098	3360000000-E	863	REMOVE EXISTING GUARDRAIL	1,555	LF	
0099	3380000000-E	862	TEMPORARY STEEL BEAM GUARDRAIL	287.5	LF	
0100	3389150000-N	SP	TEMPORARY GUARDRAIL END UNITS, TYPE ***** (TL-3)	1	EA	
0101	3435000000-N	SP	GENERIC GUARDRAIL ITEM GUARDRAIL POST CAPS	161	EA	
0102	3533000000-E	866	CHAIN LINK FENCE, *** FABRIC (60")	73	LF	
0103	3536000000-E	866	CHAIN LINK FENCE, 48" FABRIC	382	LF	
0104	3539000000-E	866	METAL LINE POSTS FOR *** CHAIN LINK FENCE (60")	7	EA	
0105	3542000000-E	866	METAL LINE POSTS FOR 48" CHAIN LINK FENCE	32	EA	
0106	3545000000-E	866	METAL TERMINAL POSTS FOR *** CHAIN LINK FENCE (60")	4	EA	
0107	3548000000-E	866	METAL TERMINAL POSTS FOR 48" CHAIN LINK FENCE	4	EA	

County : Macon

Line #	Item Number	Sec #	Description	Quantity	Unit Cost	Amount
0108	3575000000-E	SP	GENERIC FENCING ITEM WALL MOUNTED PEDESTRIAN HANDRAIL	182 LF		
0109	3628000000-E	876	RIP RAP, CLASS I	1,176 TON		
0110	3635000000-E	876	RIP RAP, CLASS II	50 TON		
0111	3649000000-E	876	RIP RAP, CLASS B	332 TON		
0112	3656000000-E	876	GEOTEXTILE FOR DRAINAGE	5,083 SY		
0113	4048000000-E	902	REINFORCED CONCRETE SIGN FOUN- DATIONS	3 CY		
0114	4054000000-E	902	PLAIN CONCRETE SIGN FOUNDA- TIONS	1 CY		
0115	4057000000-E	SP	OVERHEAD FOOTING	49 CY		
0116	4060000000-E	903	SUPPORTS, BREAKAWAY STEEL BEAM	3,159 LB		
0117	4066000000-E	903	SUPPORTS, SIMPLE STEEL BEAM	415 LB		
0118	4072000000-E	903	SUPPORTS, 3-LB STEEL U-CHANNEL	2,250 LF		
0119	4082100000-N	906	SUPPORTS, OVERHEAD SIGN STRUC- TURE AT STA ***** (13+25 -LPD-)	Lump Sum	L.S.	
0120	4082100000-N	906	SUPPORTS, OVERHEAD SIGN STRUC- TURE AT STA ***** (69+00 -L-)	Lump Sum	L.S.	
0121	4096000000-N	904	SIGN ERECTION, TYPE D	13 EA		
0122	4102000000-N	904	SIGN ERECTION, TYPE E	118 EA		
0123	4108000000-N	904	SIGN ERECTION, TYPE F	13 EA		
0124	4110000000-N	904	SIGN ERECTION, TYPE *** (GROUND MOUNTED) (A)	4 EA		

County : Macon

Line #	Item Number	Sec #	Description	Quantity	Unit Cost	Amount
0125	4116100000-N	904	SIGN ERECTION, RELOCATE TYPE **** (GROUND MOUNTED) (A)	1 EA		
0126	4116100000-N	904	SIGN ERECTION, RELOCATE TYPE **** (GROUND MOUNTED) (B)	1 EA		
0127	4116100000-N	904	SIGN ERECTION, RELOCATE TYPE **** (GROUND MOUNTED) (D)	2 EA		
0128	4116100000-N	904	SIGN ERECTION, RELOCATE TYPE **** (GROUND MOUNTED) (E)	2 EA		
0129	4116100000-N	904	SIGN ERECTION, RELOCATE TYPE **** (GROUND MOUNTED) (F)	2 EA		
0130	4138000000-N	907	DISPOSAL OF SUPPORT, STEEL BEAM	1 EA		
0131	4152000000-N	907	DISPOSAL OF SIGN SYSTEM, STEEL BEAM	1 EA		
0132	4155000000-N	907	DISPOSAL OF SIGN SYSTEM, U- CHANNEL	80 EA		
0133	4192000000-N	907	DISPOSAL OF SUPPORT, U-CHANNEL	1 EA		
0134	4360000000-N	SP	GENERIC SIGNING ITEM DISPOSAL OF SIGN SYSTEM ON SPAN WIRE	1 EA		
0135	4400000000-E	1110	WORK ZONE SIGNS (STATIONARY)	680 SF		
0136	4405000000-E	1110	WORK ZONE SIGNS (PORTABLE)	288 SF		
0137	4410000000-E	1110	WORK ZONE SIGNS (BARRICADE MOUNTED)	57 SF		
0138	4415000000-N	1115	FLASHING ARROW BOARD	1 EA		
0139	4430000000-N	1130	DRUMS	555 EA		
0140	4435000000-N	1135	CONES	80 EA		

County : Macon

Line #	Item Number	Sec #	Description	Quantity	Unit Cost	Amount
0141	4445000000-E	1145	BARRICADES (TYPE III)	64	LF	
0142	4480000000-N	1165	TMA	1	EA	
0143	4510000000-N	1190	LAW ENFORCEMENT	32	HR	
0144	4650000000-N	1251	TEMPORARY RAISED PAVEMENT MARKERS	8	EA	
0145	4685000000-E	1205	THERMOPLASTIC PAVEMENT MARKING LINES (4", 90 MILS)	7,750	LF	
0146	4686000000-E	1205	THERMOPLASTIC PAVEMENT MARKING LINES (4", 120 MILS)	17,551	LF	
0147	4688000000-E	1205	THERMOPLASTIC PAVEMENT MARKING LINES (6", 90 MILS)	975	LF	
0148	4690000000-E	1205	THERMOPLASTIC PAVEMENT MARKING LINES (6", 120 MILS)	419	LF	
0149	4695000000-E	1205	THERMOPLASTIC PAVEMENT MARKING LINES (8", 90 MILS)	1,420	LF	
0150	4697000000-E	1205	THERMOPLASTIC PAVEMENT MARKING LINES (8", 120 MILS)	2,313	LF	
0151	4700000000-E	1205	THERMOPLASTIC PAVEMENT MARKING LINES (12", 90 MILS)	265	LF	
0152	4710000000-E	1205	THERMOPLASTIC PAVEMENT MARKING LINES (24", 120 MILS)	655	LF	
0153	4721000000-E	1205	THERMOPLASTIC PAVEMENT MARKING CHARACTER (120 MILS)	36	EA	
0154	4725000000-E	1205	THERMOPLASTIC PAVEMENT MARKING SYMBOL (90 MILS)	114	EA	
0155	4726110000-E	1205	HEATED-IN-PLACE THERMOPLASTIC PAVEMENT MARKING SYMBOL (90 MILS)	52	EA	
0156	4770000000-E	1205	COLD APPLIED PLASTIC PAVEMENT MARKING LINES, TYPE ** (4") (IV)	684	LF	

County : Macon

Line #	Item Number	Sec #	Description	Quantity	Unit Cost	Amount
0157	4810000000-E	1205	PAINT PAVEMENT MARKING LINES (4")	46,348 LF		
0158	4820000000-E	1205	PAINT PAVEMENT MARKING LINES (8")	5,877 LF		
0159	4835000000-E	1205	PAINT PAVEMENT MARKING LINES (24")	1,602 LF		
0160	4840000000-N	1205	PAINT PAVEMENT MARKING CHARACTER	16 EA		
0161	4845000000-N	1205	PAINT PAVEMENT MARKING SYMBOL	162 EA		
0162	4850000000-E	1205	REMOVAL OF PAVEMENT MARKING LINES (4")	343 LF		
0163	4875000000-N	1205	REMOVAL OF PAVEMENT MARKING SYMBOLS & CHARACTERS	11 EA		
0164	4895000000-N	SP	GENERIC PAVEMENT MARKING ITEM IN LANE ROUTE SHIELD	1 EA		
0165	4900000000-N	1251	PERMANENT RAISED PAVEMENT MARKERS	4 EA		
0166	4905000000-N	1253	SNOWPLOWABLE PAVEMENT MARKERS	874 EA		
0167	5255000000-N	1413	PORTABLE LIGHTING	Lump Sum	L.S.	
0168	5325800000-E	1510	8" WATER LINE	20 LF		
0169	5326000000-E	1510	10" WATER LINE	20 LF		
0170	5326200000-E	1510	12" WATER LINE	2,045 LF		
0171	5329000000-E	1510	DUCTILE IRON WATER PIPE FITTINGS	14,400 LB		
0172	5558000000-E	1515	12" VALVE	4 EA		
0173	5571000000-E	1515	*** TAPPING SLEEVE & VALVE (1")	3 EA		
0174	5588000000-E	1515	** AIR RELEASE VALVE (12")	2 EA		

County : Macon

Line #	Item Number	Sec #	Description	Quantity	Unit Cost	Amount
0175	5648000000-N	1515	RELOCATE WATER METER	6	EA	
0176	5666000000-N	1515	FIRE HYDRANT	2	EA	
0177	5672000000-N	1515	RELOCATE FIRE HYDRANT	1	EA	
0178	5673000000-E	1515	FIRE HYDRANT LEG	28	LF	
0179	5686500000-E	1515	WATER SERVICE LINE	89	LF	
0180	5691100000-E	1520	4" SANITARY GRAVITY SEWER	134	LF	
0181	5691300000-E	1520	8" SANITARY GRAVITY SEWER	1,503	LF	
0182	5691500000-E	1520	12" SANITARY GRAVITY SEWER	2,496	LF	
0183	5691600000-E	1520	16" SANITARY GRAVITY SEWER	185	LF	
0184	5768000000-N	1520	SANITARY SEWER CLEAN-OUT	4	EA	
0185	5768500000-E	1520	SEWER SERVICE LINE	71	LF	
0186	5775000000-E	1525	4' DIA UTILITY MANHOLE	122	EA	
0187	5781000000-E	1525	UTILITY MANHOLE WALL 4' DIA	17	LF	
0188	5800000000-E	1530	ABANDON 6" UTILITY PIPE	376	LF	
0189	5801000000-E	1530	ABANDON 8" UTILITY PIPE	947	LF	
0190	5802000000-E	1530	ABANDON 10" UTILITY PIPE	1,673	LF	
0191	5804000000-E	1530	ABANDON 12" UTILITY PIPE	2,168	LF	
0192	5810000000-E	1530	ABANDON 16" UTILITY PIPE	124	LF	
0193	5816000000-N	1530	ABANDON UTILITY MANHOLE	14	EA	
0194	5835700000-E	1540	16" ENCASEMENT PIPE	90	LF	
0195	5836000000-E	1540	24" ENCASEMENT PIPE	89	LF	

County : Macon

Line #	Item Number	Sec #	Description	Quantity	Unit Cost	Amount
0196	5872500000-E	1550	BORE AND JACK OF *** (16")	90 LF		
0197	5872500000-E	1550	BORE AND JACK OF *** (24")	89 LF		
0198	5912000000-N	SP	GENERIC UTILITY ITEM TEMPORARY SANITARY SEWER BY- PASS PUMPING	Lump Sum	L.S.	
0199	6000000000-E	1605	TEMPORARY SILT FENCE	9,870 LF		
0200	6006000000-E	1610	STONE FOR EROSION CONTROL, CLASS A	760 TON		
0201	6009000000-E	1610	STONE FOR EROSION CONTROL, CLASS B	1,205 TON		
0202	6012000000-E	1610	SEDIMENT CONTROL STONE	1,475 TON		
0203	6015000000-E	1615	TEMPORARY MULCHING	9 ACR		
0204	6018000000-E	1620	SEED FOR TEMPORARY SEEDING	700 LB		
0205	6021000000-E	1620	FERTILIZER FOR TEMPORARY SEED- ING	3.5 TON		
0206	6024000000-E	1622	TEMPORARY SLOPE DRAINS	400 LF		
0207	6029000000-E	SP	SAFETY FENCE	400 LF		
0208	6030000000-E	1630	SILT EXCAVATION	1,090 CY		
0209	6036000000-E	1631	MATTING FOR EROSION CONTROL	26,850 SY		
0210	6037000000-E	SP	COIR FIBER MAT	1,510 SY		
0211	6042000000-E	1632	1/4" HARDWARE CLOTH	3,840 LF		
0212	6045000000-E	SP	*** TEMPORARY PIPE (18")	80 LF		
0213	6070000000-N	1639	SPECIAL STILLING BASINS	9 EA		
0214	6071012000-E	SP	COIR FIBER WATTLE	460 LF		

County : Macon

Line #	Item Number	Sec #	Description	Quantity	Unit Cost	Amount
0215	6071020000-E	SP	POLYACRYLAMIDE (PAM)	350	LB	
0216	6071030000-E	1640	COIR FIBER BAFFLE	45	LF	
0217	6084000000-E	1660	SEEDING & MULCHING	10.5	ACR	
0218	6087000000-E	1660	MOWING	6.5	ACR	
0219	6090000000-E	1661	SEED FOR REPAIR SEEDING	150	LB	
0220	6093000000-E	1661	FERTILIZER FOR REPAIR SEEDING	0.5	TON	
0221	6096000000-E	1662	SEED FOR SUPPLEMENTAL SEEDING	250	LB	
0222	6108000000-E	1665	FERTILIZER TOPDRESSING	5.75	TON	
0223	6111000000-E	SP	IMPERVIOUS DIKE	300	LF	
0224	6114500000-N	1667	SPECIALIZED HAND MOWING	20	MHR	
0225	6117000000-N	SP	RESPONSE FOR EROSION CONTROL	50	EA	
0226	6117500000-N	SP	CONCRETE WASHOUT STRUCTURE	13	EA	
0227	6123000000-E	1670	REFORESTATION	5.1	ACR	
0228	6126000000-E	SP	STREAMBANK REFORESTATION	0.31	ACR	
0229	6132000000-N	SP	GENERIC EROSION CONTROL ITEM FABRIC INSERT INLET PROTECTION DEVICE CLEANOUT	86	EA	
0230	6132000000-N	SP	GENERIC EROSION CONTROL ITEM FABRIC INSERT INLET PROTECTION DEVICE	43	EA	
0231	7048500000-E	1705	PEDESTRIAN SIGNAL HEAD (16", 1 SECTION W/COUNTDOWN)	14	EA	
0232	7060000000-E	1705	SIGNAL CABLE	13,955	LF	
0233	7120000000-E	1705	VEHICLE SIGNAL HEAD (12", 3 SECTION)	45	EA	

County : Macon

Line #	Item Number	Sec #	Description	Quantity	Unit Cost	Amount
0234	7132000000-E	1705	VEHICLE SIGNAL HEAD (12", 4 SECTION)	10 EA		
0235	7144000000-E	1705	VEHICLE SIGNAL HEAD (12", 5 SECTION)	14 EA		
0236	7264000000-E	1710	MESSENGER CABLE (3/8")	1,085 LF		
0237	7300000000-E	1715	UNPAVED TRENCHING (*****) (1, 2")	3,015 LF		
0238	7301000000-E	1715	DIRECTIONAL DRILL (*****) (2, 2")	1,905 LF		
0239	7324000000-N	1716	JUNCTION BOX (STANDARD SIZE)	55 EA		
0240	7360000000-N	1720	WOOD POLE	4 EA		
0241	7372000000-N	1721	GUY ASSEMBLY	7 EA		
0242	7444000000-E	1725	INDUCTIVE LOOP SAWCUT	5,200 LF		
0243	7456000000-E	1726	LEAD-IN CABLE (*****) (14-2)	13,000 LF		
0244	7481000000-N	SP	SITE SURVEY	3 EA		
0245	7481200000-N	SP	LUMINAIRE ARM FOR VIDEO SYSTEM	12 EA		
0246	7481240000-N	SP	CAMERA WITHOUT INTERNAL LOOP EMULATOR PROCESSING UNIT	12 EA		
0247	7481260000-N	SP	EXTERNAL LOOP EMULATOR PRO- CESSING UNIT	3 EA		
0248	7481280000-N	SP	RELOCATE CAMERA SENSOR UNIT	9 EA		
0249	7575142000-N	1736	900MHZ SERIAL SPREAD SPECTRUM RADIO	4 EA		
0250	7588000000-N	SP	METAL POLE WITH SINGLE MAST ARM	16 EA		
0251	7613000000-N	SP	SOIL TEST	16 EA		

County : Macon

Line #	Item Number	Sec #	Description	Quantity	Unit Cost	Amount
0252	7614100000-E	SP	DRILLED PIER FOUNDATION	144	CY	
0253	7631000000-N	SP	MAST ARM WITH METAL POLE DESIGN	16	EA	
0254	7636000000-N	1745	SIGN FOR SIGNALS	18	EA	
0255	7642200000-N	1743	TYPE II PEDESTAL WITH FOUNDATION	14	EA	
0256	7684000000-N	1750	SIGNAL CABINET FOUNDATION	4	EA	
0257	7696000000-N	1751	CONTROLLERS WITH CABINET (*****) (TYPE 2070E, BASE MOUNTED)	4	EA	
0258	7744000000-N	1751	DETECTOR CARD (TYPE 170)	34	EA	
0259	7901000000-N	1753	CABINET BASE EXTENDER	4	EA	
0260	7960000000-N	SP	METAL POLE FOUNDATION REMOVAL	1	EA	
0261	7972000000-N	SP	METAL POLE REMOVAL	1	EA	
0262	7980000000-N	SP	GENERIC SIGNAL ITEM PROTECTIVE COATING FOR PUSHBUTTON POST (BLACK)	14	EA	
0263	7980000000-N	SP	GENERIC SIGNAL ITEM PROTECTIVE COATING FOR SINGLE MAST ARM POLE (BLACK)	16	EA	

CULVERT ITEMS

0264	8126000000-N	414	CULVERT EXCAVATION, STA ***** (19+20.00 -L-)	Lump Sum	L.S.	
0265	8133000000-E	414	FOUNDATION CONDITIONING MATERIAL, BOX CULVERT	16	TON	
0266	8196000000-E	420	CLASS A CONCRETE (CULVERT)	41.7	CY	

County : Macon

Line #	Item Number	Sec #	Description	Quantity	Unit Cost	Amount
0267	8245000000-E	425	REINFORCING STEEL (CULVERT)	3,911 LB		
WALL ITEMS						
0268	8802014000-E	SP	SOLDIER PILE RETAINING WALLS	935 SF		
STRUCTURE ITEMS						
0269	8017000000-N	SP	CONSTRUCTION, MAINTENANCE, & REMOVAL OF TEMP ACCESS AT STA ***** (14+94.00 -L-)	Lump Sum	L.S.	
0270	8035000000-N	402	REMOVAL OF EXISTING STRUCTURE AT STATION ***** (14+94.00 -L-)	Lump Sum	L.S.	
0271	8065000000-N	SP	ASBESTOS ASSESSMENT	Lump Sum	L.S.	
0272	8121000000-N	412	UNCLASSIFIED STRUCTURE EXCAVA- TION AT STATION ***** (14+94.00 -L-)	Lump Sum	L.S.	
0273	8175000000-E	420	CLASS AA CONCRETE (BRIDGE)	43.7 CY		
0274	8182000000-E	420	CLASS A CONCRETE (BRIDGE)	59.4 CY		
0275	8210000000-N	422	BRIDGE APPROACH SLABS, STATION ***** (14+94.00 -L-)	Lump Sum	L.S.	
0276	8217000000-E	425	REINFORCING STEEL (BRIDGE)	10,862 LB		
0277	8224000000-E	425	EPOXY COATED REINFORCING STEEL (BRIDGE)	1,092 LB		
0278	8328200000-E	450	PILE DRIVING EQUIPMENT SETUP FOR *** STEEL PILES (HP 12 X 53)	14 EA		
0279	8364000000-E	450	HP12X53 STEEL PILES	980 LF		

County : Macon

Line #	Item Number	Sec #	Description	Quantity	Unit Cost	Amount
0280	8482000000-E	460	THREE BAR METAL RAIL	92.2		
					LF	
0281	8505000000-E	460	VERTICAL CONCRETE BARRIER RAIL	100		
					LF	
0282	8608000000-E	876	RIP RAP CLASS II (2'-0" THICK)	285		
					TON	
0283	8622000000-E	876	GEOTEXTILE FOR DRAINAGE	320		
					SY	
0284	8657000000-N	430	ELASTOMERIC BEARINGS	Lump Sum	L.S.	
0285	8753200000-E	430	3'-0" X 3'-3" PRESTRESSED CONC BOX BEAMS	1,100		
					LF	

0934/Nov14/Q326971.338/D1250663908000/E285

Total Amount Of Bid For Entire Project :

COMBINED GOAL SET: 7.00%
COMBINED GOAL OBT: 8.99%

Vendor 1 of 3: BUCHANAN AND SONS INC (5018)
Call Order 002 (Proposal: C204130)

Bid Information

Proposal County: MACON
Vendor Address: P.O. Box 123
Whittier , NC , 28789
Signature Check: Christopher_Buchanan_5018
Time Bid Received: November 20, 2018 01:48 PM
Amendment Count: 2

Bid Checksum: FA62D1A7
Bid Total: \$14,032,805.00
Items Total: \$14,032,805.00
Time Total: \$0.00

Bidding Errors:
None.

Vendor 1 of 3: BUCHANAN AND SONS INC (5018)
Call Order 002 (Proposal: C204130)

Bid Bond Information

Projects:	Bond Maximum:
Counties:	State of Incorporation:
Bond ID: SNC18303642	Agency Execution Date: 11/19/2018 12
Paid by Check: No	Surety Name: surety2000
Bond Percent: 5%	Bond Agency Name: Hudson Insurance Company

Bidder 1 of 3

Vendor 5018's Bid Information for Call 002, Letting L181120, 11/20/18

Buchanan and Sons Inc (5018)
 Call Order 002 (Proposal ID C204130)

LIST OF DBE PARTICIPANTS

VENDOR NUMBER	DBE NAME ADDRESS	WORK CODE TYPE OF WORK	CERT TYPE AMOUNT	
9615	OWLE CONTAINER INCORPORATED		Sub	962,850.50
	P.O. BOX 1281, ANDREWS, NC 28901			
6101	DMJ'S INCORPORATED P.O. BOX 924 , ROBBINSVILLE, NC 28771		Sub	-52,580.00- 180,050.00
	CONCRETE SPECIALTY CONTRACTORS			
	BULLINGTON CONSTRUCTION			
				TOTAL: -1,015,430.50- 940,584.96
				7.24% 140,248.00
				TOTAL: \$1,260,882.96
				8.99%

Miscellaneous Data Info - Contractor Responses:
 =====

NON-COLLUSION AND DEBARMENT CERTIFICATION

Explanation of the prospective bidder that is unable to certify to any of the statements in this certification:

Explanation:
 NOT ANSWERED
 NOT ANSWERED
 NOT ANSWERED
 NOT ANSWERED

AWARD LIMITS ON MULTIPLE PROJECTS

By answering YES to this statement, the bidder acknowledges that they are using the award limits on multiple projects. No

It is the desire of the Bidder to be awarded contracts, the value of which will not exceed a total of NOT ANSWERED for those projects indicated herein, for which bids will be opened on (MM/DD/YY)

The Award Limits shall apply to the following projects:

Contract Number	County
NOT ANSWERED	
NOT ANSWERED	
NOT ANSWERED	
NOT ANSWERED	
NOT ANSWERED	
NOT ANSWERED	

Bid Bond Data Info - Contractor Responses:
 =====

BondID: SNC18303642

Bidder 1 of 3

Surety Registry Agency: surety2000

Verified?: Yes

Surety Agency: Hudson Insurance Company

Bond Execution Date: 11/19/2018 12

Bond Amount: \$701,640.25 (Five Percent of Bid)

Contract ID: C204130

Project(s): STATE FUNDED

Letting Date: 11-20-18 Call Order: 002

Bidder: 5018 - Buchanan and Sons Inc

Line No.	Item Description	Approx. Quantity and Units	Unit Price Dollars Cts	Bid Amount Dollars Ct
Section 0001 ROADWAY ITEMS				
Alt Group				
0001	0000100000-N MOBILIZATION	LUMP	LUMP	725,000.00
0002	0000400000-N CONSTRUCTION SURVEYING	LUMP	LUMP	180,000.00
0003	0015000000-N SEALING ABANDONED WELLS	1.000 EA	2,303.66000	2,303.66
0004	0030000000-N TYPE II MODIFIED APPROACH FILL, STATION ***** (14+94.00 -L-)	LUMP	LUMP	15,000.00
0005	0043000000-N GRADING	LUMP	LUMP	910,000.00
0006	0050000000-E SUPPLEMENTARY CLEARING & GRUB-BING	2.000 ACR	8,400.00000	16,800.00
0007	0057000000-E UNDERCUT EXCAVATION	1,050.000 CY	20.00000	21,000.00
0008	0134000000-E DRAINAGE DITCH EXCAVATION	3,630.000 CY	21.50000	78,045.00
0009	0195000000-E SELECT GRANULAR MATERIAL	3,300.000 CY	65.00000	214,500.00
0010	0196000000-E GEOTEXTILE FOR SOIL STABILIZATION	3,500.000 SY	1.90000	6,650.00

Contract ID: C204130

Project(s): STATE FUNDED

Letting Date: 11-20-18 Call Order: 002

Bidder: 5018 - Buchanan and Sons Inc

Line No.	Item Description	Approx. Quantity and Units	Unit Price Dollars Cts	Bid Amount Dollars Ct
0011	0199000000-E TEMPORARY SHORING	200.000 SF	114.00000	22,800.00
0012	0223000000-E ROCK PLATING	200.000 SY	72.00000	14,400.00
0013	0225000000-E REINFORCED SOIL SLOPES	130.000 SY	190.00000	24,700.00
0014	0318000000-E FOUNDATION CONDITIONING MATERIAL, MINOR STRUCTURES	1,441.000 TON	50.00000	72,050.00
0015	0320000000-E FOUNDATION CONDITIONING GEOTEXTILE	5,114.000 SY	4.00000	20,456.00
0016	0335200000-E 15" DRAINAGE PIPE	248.000 LF	65.20000	16,169.60
0017	0335400000-E 24" DRAINAGE PIPE	28.000 LF	75.00000	2,100.00
0018	0335500000-E 30" DRAINAGE PIPE	112.000 LF	92.30000	10,337.60
0019	0335850000-E **" DRAINAGE PIPE ELBOWS (15")	2.000 EA	545.00000	1,090.00
0020	0366000000-E 15" RC PIPE CULVERTS, CLASS III	396.000 LF	60.50000	23,958.00
0021	0372000000-E 18" RC PIPE CULVERTS, CLASS III	400.000 LF	72.00000	28,800.00
0022	0378000000-E 24" RC PIPE CULVERTS, CLASS III	40.000 LF	89.50000	3,580.00

Contract ID: C204130

Project(s): STATE FUNDED

Letting Date: 11-20-18 Call Order: 002

Bidder: 5018 - Buchanan and Sons Inc

Line No.	Item Description	Approx. Quantity and Units	Unit Price Dollars Cts	Bid Amount Dollars Ct
0023	0390000000-E 36" RC PIPE CULVERTS, CLASS III	88.000	109.00000	9,592.00
		LF		
0024	0402000000-E 48" RC PIPE CULVERTS, CLASS III	608.000	182.00000	110,656.00
		LF		
0025	0448000000-E ****" RC PIPE CULVERTS, CLASS IV (48")	92.000	340.00000	31,280.00
		LF		
0026	0448200000-E 15" RC PIPE CULVERTS, CLASS IV	2,528.000	76.10000	192,380.80
		LF		
0027	0448300000-E 18" RC PIPE CULVERTS, CLASS IV	376.000	84.00000	31,584.00
		LF		
0028	0448400000-E 24" RC PIPE CULVERTS, CLASS IV	304.000	115.00000	34,960.00
		LF		
0029	0448500000-E 30" RC PIPE CULVERTS, CLASS IV	544.000	116.50000	63,376.00
		LF		
0030	0448600000-E 36" RC PIPE CULVERTS, CLASS IV	836.000	170.00000	142,120.00
		LF		
0031	0448700000-E 42" RC PIPE CULVERTS, CLASS IV	388.000	171.00000	66,348.00
		LF		
0032	0588000000-E 18" CS PIPE CULVERTS, 0.064" THICK	36.000	73.00000	2,628.00
		LF		
0033	0594000000-E 24" CS PIPE CULVERTS, 0.064" THICK	12.000	168.00000	2,016.00
		LF		
0034	0636000000-E **" CS PIPE ELBOWS, *****" THICK (18", 0.064")	1.000	480.00000	480.00
		EA		

Contract ID: C204130

Project(s): STATE FUNDED

Letting Date: 11-20-18 Call Order: 002

Bidder: 5018 - Buchanan and Sons Inc

Line No.	Item Description	Approx. Quantity and Units	Unit Price		Bid Amount	
			Dollars	Cts	Dollars	Ct
0035	0986000000-E GENERIC PIPE ITEM 15" CURED IN PLACE PIPE	106.000 LF	132.00000		13,992.00	
0036	0986000000-E GENERIC PIPE ITEM 18" CURED IN PLACE PIPE	255.000 LF	177.00000		45,135.00	
0037	0986000000-E GENERIC PIPE ITEM 24" CURED IN PLACE PIPE	155.000 LF	268.00000		41,540.00	
0038	0986000000-E GENERIC PIPE ITEM 30" CURED IN PLACE PIPE	185.000 LF	285.00000		52,725.00	
0039	0995000000-E PIPE REMOVAL	1,746.000 LF	14.50000		25,317.00	
0040	1099500000-E SHALLOW UNDERCUT	150.000 CY	15.50000		2,325.00	
0041	1099700000-E CLASS IV SUBGRADE STABILIZA- TION	250.000 TON	42.00000		10,500.00	
0042	1121000000-E AGGREGATE BASE COURSE	516.000 TON	39.00000		20,124.00	
0043	1220000000-E INCIDENTAL STONE BASE	2,050.000 TON	49.00000		100,450.00	
0044	1275000000-E PRIME COAT	175.000 GAL	30.00000		5,250.00	
0045	1297000000-E MILLING ASPHALT PAVEMENT, ***"DEPTH (1-1/2")	2,590.000 SY	9.00000		23,310.00	
0046	1330000000-E INCIDENTAL MILLING	5,100.000 SY	12.00000		61,200.00	

Contract ID: C204130

Project(s): STATE FUNDED

Letting Date: 11-20-18 Call Order: 002

Bidder: 5018 - Buchanan and Sons Inc

Line No.	Item Description	Approx. Quantity and Units	Unit Price Dollars Cts	Bid Amount Dollars Ct
0047	1491000000-E ASPHALT CONC BASE COURSE, TYPE B25.0C	7,050.000 TON	112.00000	789,600.00
0048	1503000000-E ASPHALT CONC INTERMEDIATE COURSE, TYPE I19.0C	4,810.000 TON	112.00000	538,720.00
0049	1523000000-E ASPHALT CONC SURFACE COURSE, TYPE S9.5C	9,610.000 TON	106.00000	1,018,660.00
0050	1575000000-E ASPHALT BINDER FOR PLANT MIX	1,130.000 TON	864.00000	976,320.00
0051	1693000000-E ASPHALT PLANT MIX, PAVEMENT REPAIR	200.000 TON	250.00000	50,000.00
0052	2022000000-E SUBDRAIN EXCAVATION	67.200 CY	25.00000	1,680.00
0053	2026000000-E GEOTEXTILE FOR SUBSURFACE DRAINS	200.000 SY	6.50000	1,300.00
0054	2036000000-E SUBDRAIN COARSE AGGREGATE	33.600 CY	95.00000	3,192.00
0055	2044000000-E 6" PERFORATED SUBDRAIN PIPE	200.000 LF	18.00000	3,600.00
0056	2070000000-N SUBDRAIN PIPE OUTLET	1.000 EA	580.00000	580.00
0057	2077000000-E 6" OUTLET PIPE	6.000 LF	40.50000	243.00
0058	2253000000-E PIPE COLLARS	3.148 CY	2,636.00000	8,298.13

Contract ID: C204130

Project(s): STATE FUNDED

Letting Date: 11-20-18 Call Order: 002

Bidder: 5018 - Buchanan and Sons Inc

Line No.	Item Description	Approx. Quantity and Units	Unit Price		Bid Amount	
			Dollars	Cts	Dollars	Ct
0059	2264000000-E PIPE PLUGS CY	0.130	13,152.00000		1,709.76	
0060	2275000000-E FLOWABLE FILL CY	52.000	320.00000		16,640.00	
0061	2286000000-N MASONRY DRAINAGE STRUCTURES EA	101.000	2,435.00000		245,935.00	
0062	2308000000-E MASONRY DRAINAGE STRUCTURES LF	61.100	245.00000		14,969.50	
0063	2364000000-N FRAME WITH TWO GRATES, STD 840.16 EA	25.000	750.00000		18,750.00	
0064	2366000000-N FRAME WITH TWO GRATES, STD 840.24 EA	8.000	700.00000		5,600.00	
0065	2367000000-N FRAME WITH TWO GRATES, STD 840.29 EA	4.000	700.00000		2,800.00	
0066	2374000000-N FRAME WITH GRATE & HOOD, STD 840.03, TYPE ** (E) EA	10.000	820.00000		8,200.00	
0067	2374000000-N FRAME WITH GRATE & HOOD, STD 840.03, TYPE ** (F) EA	16.000	820.00000		13,120.00	
0068	2374000000-N FRAME WITH GRATE & HOOD, STD 840.03, TYPE ** (G) EA	25.000	830.00000		20,750.00	
0069	2396000000-N FRAME WITH COVER, STD 840.54 EA	18.000	610.00000		10,980.00	
0070	2451000000-N CONCRETE TRANSITIONAL SECTION FOR DROP INLET EA	22.000	950.00000		20,900.00	

Contract ID: C204130

Project(s): STATE FUNDED

Letting Date: 11-20-18 Call Order: 002

Bidder: 5018 - Buchanan and Sons Inc

Line No.	Item Description	Approx. Quantity and Units	Unit Price Dollars Cts	Bid Amount Dollars Ct
0071	2538000000-E ***'-***" CONCRETE CURB & GUTTER (2'-9")	460.000 LF	34.20000	15,732.00
0072	2542000000-E 1'-6" CONCRETE CURB & GUTTER	2,800.000 LF	24.25000	67,900.00
0073	2549000000-E 2'-6" CONCRETE CURB & GUTTER	11,560.000 LF	30.75000	355,470.00
0074	2556000000-E SHOULDER BERM GUTTER	48.000 LF	52.50000	2,520.00
0075	2570000000-N MODIFIED CONCRETE FLUME	1.000 EA	2,625.00000	2,625.00
0076	2591000000-E 4" CONCRETE SIDEWALK	4,600.000 SY	50.50000	232,300.00
0077	2605000000-N CONCRETE CURB RAMPS	39.000 EA	2,000.00000	78,000.00
0078	2612000000-E 6" CONCRETE DRIVEWAY	714.000 SY	79.50000	56,763.00
0079	2619000000-E 4" CONCRETE PAVED DITCH	50.000 SY	73.50000	3,675.00
0080	2655000000-E 5" MONOLITHIC CONCRETE ISLANDS (KEYED IN)	1,600.000 SY	73.50000	117,600.00
0081	2657000000-E ***" MONOLITHIC CONCRETE MEDIAN (*****) (5-1/2", KEYED IN)	20.000 SY	85.00000	1,700.00

Contract ID: C204130

Project(s): STATE FUNDED

Letting Date: 11-20-18 Call Order: 002

Bidder: 5018 - Buchanan and Sons Inc

Line No.	Item Description	Approx. Quantity and Units	Unit Price Dollars Cts	Bid Amount Dollars Ct
0082	2738000000-E GENERIC PAVING ITEM REINFORCED CONCRETE DRIVEWAY	259.000 SY	90.00000	23,310.00
0083	2761000000-E GENERIC PAVING ITEM 8" CONCRETE DRIVEWAY	90.000 SY	120.00000	10,800.00
0084	2800000000-N ADJUSTMENT OF CATCH BASINS	10.000 EA	1,000.00000	10,000.00
0085	2830000000-N ADJUSTMENT OF MANHOLES	4.000 EA	1,550.00000	6,200.00
0086	2845000000-N ADJUSTMENT OF METER BOXES OR VALVE BOXES	7.000 EA	995.00000	6,965.00
0087	2860000000-N CONVERT EXISTING CATCH BASIN TO JUNCTION BOX	1.000 EA	2,200.00000	2,200.00
0088	2905000000-N CONVERT EXISTING DROP INLET TO JUNCTION BOX	2.000 EA	2,200.00000	4,400.00
0089	2995000000-N GENERIC DRAINAGE ITEM CONVERT EXISTING CATCH BASIN TO TRAFFIC BEARING JUNCTION BOX	2.000 EA	1,700.00000	3,400.00
0090	3030000000-E STEEL BEAM GUARDRAIL	2,000.000 LF	18.90000	37,800.00
0091	3045000000-E STEEL BEAM GUARDRAIL, SHOP CURVED	112.500 LF	23.10000	2,598.75
0092	3150000000-N ADDITIONAL GUARDRAIL POSTS	15.000 EA	47.25000	708.75

Contract ID: C204130

Project(s): STATE FUNDED

Letting Date: 11-20-18 Call Order: 002

Bidder: 5018 - Buchanan and Sons Inc

Line No.	Item Description	Approx. Quantity and Units	Unit Price Dollars Cts	Bid Amount Dollars Ct
0093	3195000000-N GUARDRAIL END UNITS, TYPE AT-1	1.000	750.00000	750.00
		EA		
0094	3210000000-N GUARDRAIL END UNITS, TYPE CAT-1	6.000	700.00000	4,200.00
		EA		
0095	3215000000-N GUARDRAIL ANCHOR UNITS, TYPE III	7.000	2,100.00000	14,700.00
		EA		
0096	3287000000-N GUARDRAIL END UNITS, TYPE TL-3	6.000	3,300.00000	19,800.00
		EA		
0097	3288000000-N GUARDRAIL END UNITS, TYPE TL-2	4.000	3,520.00000	14,080.00
		EA		
0098	3360000000-E REMOVE EXISTING GUARDRAIL	1,555.000	1.15000	1,788.25
		LF		
0099	3380000000-E TEMPORARY STEEL BEAM GUARDRAIL	287.500	13.60000	3,910.00
		LF		
0100	3389150000-N TEMPORARY GUARDRAIL END UNITS, TYPE ***** (TL-3)	1.000	3,700.00000	3,700.00
		EA		
0101	3435000000-N GENERIC GUARDRAIL ITEM GUARDRAIL POST CAPS	161.000	45.40000	7,309.40
		EA		
0102	3533000000-E CHAIN LINK FENCE, **" FABRIC (60")	73.000	20.45000	1,492.85
		LF		
0103	3536000000-E CHAIN LINK FENCE, 48" FABRIC	382.000	15.90000	6,073.80
		LF		
0104	3539000000-E METAL LINE POSTS FOR **" CHAINLINK FENCE (60")	7.000	85.50000	598.50
		EA		

Contract ID: C204130

Project(s): STATE FUNDED

Letting Date: 11-20-18 Call Order: 002

Bidder: 5018 - Buchanan and Sons Inc

Line No.	Item Description	Approx. Quantity and Units	Unit Price Dollars Cts	Bid Amount Dollars Ct
0105	3542000000-E METAL POSTS FOR 48" CHAINLINK FENCE	32.000 EA	73.75000	2,360.00
0106	3545000000-E METAL TERMINAL POSTS FOR **" CHAIN LINK FENCE (60")	4.000 EA	230.00000	920.00
0107	3548000000-E METAL TERMINAL POSTS FOR 48" CHAIN LINK FENCE	4.000 EA	170.00000	680.00
0108	3575000000-E GENERIC FENCING ITEM WALL MOUNTED PEDESTRIAN HANDRAIL	182.000 LF	170.00000	30,940.00
0109	3628000000-E RIP RAP, CLASS I	1,176.000 TON	80.50000	94,668.00
0110	3635000000-E RIP RAP, CLASS II	50.000 TON	72.00000	3,600.00
0111	3649000000-E RIP RAP, CLASS B	332.000 TON	82.00000	27,224.00
0112	3656000000-E GEOTEXTILE FOR DRAINAGE	5,083.000 SY	2.75000	13,978.25
0113	4048000000-E REINFORCED CONCRETE SIGN FOUNDATIONS	3.000 CY	735.00000	2,205.00
0114	4054000000-E PLAIN CONCRETE SIGN FOUNDATIONS	1.000 CY	735.00000	735.00
0115	4057000000-E OVERHEAD FOOTING	49.000 CY	1,155.00000	56,595.00
0116	4060000000-E SUPPORTS, BREAKAWAY STEEL BEAM	3,159.000 LB	6.30000	19,901.70

Contract ID: C204130

Project(s): STATE FUNDED

Letting Date: 11-20-18 Call Order: 002

Bidder: 5018 - Buchanan and Sons Inc

Line No.	Item Description	Approx. Quantity and Units	Unit Price Dollars Cts	Bid Amount Dollars Ct
0117	4066000000-E SUPPORTS, SIMPLE STEEL BEAM	415.000 LB	6.30000	2,614.50
0118	4072000000-E SUPPORTS, 3-LB STEEL U-CHANNEL	2,250.000 LF	8.00000	18,000.00
0119	4082100000-N SUPPORTS, OVERHEAD SIGN STRUC-TURE AT STA ***** (13+25 -LPD-)	LUMP	LUMP	85,000.00
0120	4082100000-N SUPPORTS, OVERHEAD SIGN STRUC-TURE AT STA ***** (69+00 -L-)	LUMP	LUMP	75,000.00
0121	4096000000-N SIGN ERECTION, TYPE D	13.000 EA	125.00000	1,625.00
0122	4102000000-N SIGN ERECTION, TYPE E	118.000 EA	74.00000	8,732.00
0123	4108000000-N SIGN ERECTION, TYPE F	13.000 EA	155.00000	2,015.00
0124	4110000000-N SIGN ERECTION, TYPE *** (GROUND MOUNTED) (A)	4.000 EA	735.00000	2,940.00
0125	4116100000-N SIGN ERECTION, RELOCATE TYPE **** (GROUND MOUNTED) (A)	1.000 EA	735.00000	735.00
0126	4116100000-N SIGN ERECTION, RELOCATE TYPE **** (GROUND MOUNTED) (B)	1.000 EA	735.00000	735.00
0127	4116100000-N SIGN ERECTION, RELOCATE TYPE **** (GROUND MOUNTED) (D)	2.000 EA	116.00000	232.00

Contract ID: C204130

Project(s): STATE FUNDED

Letting Date: 11-20-18 Call Order: 002

Bidder: 5018 - Buchanan and Sons Inc

Line No.	Item Description	Approx. Quantity and Units	Unit Price Dollars Cts	Bid Amount Dollars Ct
0128	4116100000-N SIGN ERECTION, RELOCATE TYPE **** (GROUND MOUNTED) (E)	2.000 EA	74.00000	148.00
0129	4116100000-N SIGN ERECTION, RELOCATE TYPE **** (GROUND MOUNTED) (F)	2.000 EA	165.00000	330.00
0130	4138000000-N DISPOSAL OF SUPPORT, STEEL BEAM	1.000 EA	210.00000	210.00
0131	4152000000-N DISPOSAL OF SIGN SYSTEM, STEELBEAM	1.000 EA	230.00000	230.00
0132	4155000000-N DISPOSAL OF SIGN SYSTEM, U-CHANNEL	80.000 EA	1.15000	92.00
0133	4192000000-N DISPOSAL OF SUPPORT, U-CHANNEL	1.000 EA	1.15000	1.15
0134	4360000000-N GENERIC SIGNING ITEM DISPOSAL OF SIGN SYSTEM ON SPAN WIRE	1.000 EA	2,300.00000	2,300.00
0135	4400000000-E WORK ZONE SIGNS (STATIONARY)	680.000 SF	14.30000	9,724.00
0136	4405000000-E WORK ZONE SIGNS (PORTABLE)	288.000 SF	32.10000	9,244.80
0137	4410000000-E WORK ZONE SIGNS (BARRICADE MOUNTED)	57.000 SF	11.50000	655.50
0138	4415000000-N FLASHING ARROW BOARD	1.000 EA	2,500.00000	2,500.00

Contract ID: C204130

Project(s): STATE FUNDED

Letting Date: 11-20-18 Call Order: 002

Bidder: 5018 - Buchanan and Sons Inc

Line No.	Item Description	Approx. Quantity and Units	Unit Price		Bid Amount	
			Dollars	Cts	Dollars	Ct
0139	4430000000-N DRUMS EA	555.000	63.00000		34,965.00	
0140	4435000000-N CONES EA	80.000	24.00000		1,920.00	
0141	4445000000-E BARRICADES (TYPE III) LF	64.000	31.00000		1,984.00	
0142	4480000000-N TMA EA	1.000	50,000.00000		50,000.00	
0143	4510000000-N LAW ENFORCEMENT HR	32.000	68.00000		2,176.00	
0144	4650000000-N TEMPORARY RAISED PAVEMENT MARKERS EA	8.000	115.00000		920.00	
0145	4685000000-E THERMOPLAST IC PAVEMENT MARKING LINES (4", 90 MILS) LF	7,750.000	0.95000		7,362.50	
0146	4686000000-E THERMOPLAST IC PAVEMENT MARKING LINES (4", 120 MILS) LF	17,551.000	1.00000		17,551.00	
0147	4688000000-E THERMOPLAST IC PAVEMENT MARKING LINES (6", 90 MILS) LF	975.000	3.40000		3,315.00	
0148	4690000000-E THERMOPLAST IC PAVEMENT MARKING LINES (6", 120 MILS) LF	419.000	3.70000		1,550.30	
0149	4695000000-E THERMOPLAST IC PAVEMENT MARKING LINES (8", 90 MILS) LF	1,420.000	2.30000		3,266.00	
0150	4697000000-E THERMOPLAST IC PAVEMENT MARKING LINES (8", 120 MILS) LF	2,313.000	3.40000		7,864.20	

Contract ID: C204130

Project(s): STATE FUNDED

Letting Date: 11-20-18 Call Order: 002

Bidder: 5018 - Buchanan and Sons Inc

Line No.	Item Description	Approx. Quantity and Units	Unit Price		Bid Amount	
			Dollars	Cts	Dollars	Ct
0151	4700000000-E THERMOPLAST IC PAVEMENT MARKING LINES (12", 90 MILS)	265.000 LF	3.00000		795.00	
0152	4710000000-E THERMOPLAST IC PAVEMENT MARKING LINES (24", 120 MILS)	655.000 LF	8.00000		5,240.00	
0153	4721000000-E THERMOPLAST IC PAVEMENT MARKING CHARACTER (120 MILS)	36.000 EA	125.00000		4,500.00	
0154	4725000000-E THERMOPLAST IC PAVEMENT MARKING SYMBOL (90 MILS)	114.000 EA	136.00000		15,504.00	
0155	4726110000-E HEATED-IN-PAVEMENT LACE THERMOPLASTIC MARKING SYMBOL (90 MILS)	52.000 EA	370.00000		19,240.00	
0156	4770000000-E COLD APPLIED PLASTIC PAVEMENT MARKING LINES, TYPE ** (4") (IV)	684.000 LF	3.00000		2,052.00	
0157	4810000000-E PAINT PAVEMENT MARKING LINES (4")	46,348.000 LF	0.30000		13,904.40	
0158	4820000000-E PAINT PAVEMENT MARKING LINES (8")	5,877.000 LF	1.15000		6,758.55	
0159	4835000000-E PAINT PAVEMENT MARKING LINES (24")	1,602.000 LF	3.40000		5,446.80	
0160	4840000000-N PAINT PAVEMENT MARKING CHARACTER	16.000 EA	65.00000		1,040.00	
0161	4845000000-N PAINT PAVEMENT MARKING SYMBOL	162.000 EA	65.00000		10,530.00	

Contract ID: C204130

Project(s): STATE FUNDED

Letting Date: 11-20-18 Call Order: 002

Bidder: 5018 - Buchanan and Sons Inc

Line No.	Item Description	Approx. Quantity and Units	Unit Price Dollars Cts	Bid Amount Dollars Ct
0162	4850000000-E REMOVAL OF PAVEMENT MARKING LINES (4")	343.000 LF	2.30000	788.90
0163	4875000000-N REMOVAL OF PAVEMENT MARKING SYMBOLS & CHARACTERS	11.000 EA	85.00000	935.00
0164	4895000000-N GENERIC PAVEMENT MARKING ITEM IN LANE ROUTE SHIELD	1.000 EA	4,000.00000	4,000.00
0165	4900000000-N PERMANENT RAISED PAVEMENT MARKERS	4.000 EA	230.00000	920.00
0166	4905000000-N SNOWPLOWABLE PAVEMENT MARKERS	874.000 EA	32.00000	27,968.00
0167	5255000000-N PORTABLE LIGHTING	LUMP	LUMP	111,000.00
0168	5325800000-E 8" WATER LINE	20.000 LF	116.00000	2,320.00
0169	5326000000-E 10" WATER LINE	20.000 LF	144.00000	2,880.00
0170	5326200000-E 12" WATER LINE	2,045.000 LF	134.50000	275,052.50
0171	5329000000-E DUCTILE IRON WATER PIPE FITTINGS	14,400.000 LB	8.00000	115,200.00
0172	5558000000-E 12" VALVE	4.000 EA	4,950.00000	19,800.00
0173	5571000000-E *** TAPPING SLEEVE & VALVE (1")	3.000 EA	1,750.00000	5,250.00

Contract ID: C204130

Project(s): STATE FUNDED

Letting Date: 11-20-18 Call Order: 002

Bidder: 5018 - Buchanan and Sons Inc

Line No.	Item Description	Approx. Quantity and Units	Unit Price Dollars Cts	Bid Amount Dollars Ct
0174	5588000000-E *" AIR RELEASE VALVE (12")	2.000 EA	6,750.00000	13,500.00
0175	5648000000-N RELOCATE WATER METER	6.000 EA	2,400.00000	14,400.00
0176	5666000000-N FIRE HYDRANT	2.000 EA	5,500.00000	11,000.00
0177	5672000000-N RELOCATE FIRE HYDRANT	1.000 EA	2,300.00000	2,300.00
0178	5673000000-E FIRE HYDRANT LEG	28.000 LF	182.00000	5,096.00
0179	5686500000-E WATER SERVICE LINE	89.000 LF	40.00000	3,560.00
0180	5691100000-E 4" SANITARY GRAVITY SEWER	134.000 LF	100.00000	13,400.00
0181	5691300000-E 8" SANITARY GRAVITY SEWER	1,503.000 LF	180.00000	270,540.00
0182	5691500000-E 12" SANITARY GRAVITY SEWER	2,496.000 LF	220.00000	549,120.00
0183	5691600000-E 16" SANITARY GRAVITY SEWER	185.000 LF	290.00000	53,650.00
0184	5768000000-N SANITARY SEWER CLEAN-OUT	4.000 EA	1,200.00000	4,800.00
0185	5768500000-E SEWER SERVICE LINE	71.000 LF	52.00000	3,692.00

Contract ID: C204130

Project(s): STATE FUNDED

Letting Date: 11-20-18 Call Order: 002

Bidder: 5018 - Buchanan and Sons Inc

Line No.	Item Description	Approx. Quantity and Units	Unit Price Dollars Cts	Bid Amount Dollars Ct
0186	5775000000-E 4' DIA UTILITY MANHOLE	122.000 EA	3,850.00000	469,700.00
0187	5781000000-E UTILITY MANHOLE WALL 4' DIA	17.000 LF	450.00000	7,650.00
0188	5800000000-E ABANDON 6" UTILITY PIPE	376.000 LF	9.75000	3,666.00
0189	5801000000-E ABANDON 8" UTILITY PIPE	947.000 LF	10.00000	9,470.00
0190	5802000000-E ABANDON 10" UTILITY PIPE	1,673.000 LF	15.00000	25,095.00
0191	5804000000-E ABANDON 12" UTILITY PIPE	2,168.000 LF	19.00000	41,192.00
0192	5810000000-E ABANDON 16" UTILITY PIPE	124.000 LF	24.00000	2,976.00
0193	5816000000-N ABANDON UTILITY MANHOLE	14.000 EA	2,600.00000	36,400.00
0194	5835700000-E 16" ENCASEMENT PIPE	90.000 LF	104.00000	9,360.00
0195	5836000000-E 24" ENCASEMENT PIPE	89.000 LF	190.00000	16,910.00
0196	5872500000-E BORE AND JACK OF **" (16")	90.000 LF	740.00000	66,600.00
0197	5872500000-E BORE AND JACK OF **" (24")	89.000 LF	820.00000	72,980.00

Contract ID: C204130

Project(s): STATE FUNDED

Letting Date: 11-20-18 Call Order: 002

Bidder: 5018 - Buchanan and Sons Inc

Line No.	Item Description	Approx. Quantity and Units	Unit Price Dollars Cts	Bid Amount Dollars Ct
0198	5912000000-N GENERIC UTILITY ITEM TEMPORARY SANITARY SEWER BY-PASS PUMPING	LUMP	LUMP	34,000.00
0199	6000000000-E TEMPORARY SILT FENCE	9,870.000 LF	2.65000	26,155.50
0200	6006000000-E STONE FOR EROSION CONTROL, CLASS A	760.000 TON	84.50000	64,220.00
0201	6009000000-E STONE FOR EROSION CONTROL, CLASS B	1,205.000 TON	71.50000	86,157.50
0202	6012000000-E SEDIMENT CONTROL STONE	1,475.000 TON	70.00000	103,250.00
0203	6015000000-E TEMPORARY MULCHING	9.000 ACR	1,050.00000	9,450.00
0204	6018000000-E SEED FOR TEMPORARY SEEDING	700.000 LB	2.10000	1,470.00
0205	6021000000-E FERTILIZER FOR TEMPORARY SEEDING	3.500 TON	850.00000	2,975.00
0206	6024000000-E TEMPORARY SLOPE DRAINS	400.000 LF	14.70000	5,880.00
0207	6029000000-E SAFETY FENCE	400.000 LF	2.00000	800.00
0208	6030000000-E SILT EXCAVATION	1,090.000 CY	21.00000	22,890.00

Contract ID: C204130

Project(s): STATE FUNDED

Letting Date: 11-20-18 Call Order: 002

Bidder: 5018 - Buchanan and Sons Inc

Line No.	Item Description	Approx. Quantity and Units	Unit Price Dollars Cts	Bid Amount Dollars Ct
0209	6036000000-E MATTING FOR EROSION CONTROL	26,850.000 SY	1.90000	51,015.00
0210	6037000000-E COIR FIBER MAT	1,510.000 SY	6.30000	9,513.00
0211	6042000000-E 1/4" HARDWARE CLOTH	3,840.000 LF	6.30000	24,192.00
0212	6045000000-E *** TEMPORARY PIPE (18")	80.000 LF	39.00000	3,120.00
0213	6070000000-N SPECIAL STILLING BASINS	9.000 EA	200.00000	1,800.00
0214	6071012000-E COIR FIBER WATTLE	460.000 LF	12.00000	5,520.00
0215	6071020000-E POLYACRYLAMIDE (PAM)	350.000 LB	10.00000	3,500.00
0216	6071030000-E COIR FIBER BAFFLE	45.000 LF	7.35000	330.75
0217	6084000000-E SEEDING & MULCHING	10.500 ACR	2,200.00000	23,100.00
0218	6087000000-E MOWING	6.500 ACR	210.00000	1,365.00
0219	6090000000-E SEED FOR REPAIR SEEDING	150.000 LB	2.10000	315.00
0220	6093000000-E FERTILIZER FOR REPAIR SEEDING	0.500 TON	1,200.00000	600.00

Contract ID: C204130

Project(s): STATE FUNDED

Letting Date: 11-20-18 Call Order: 002

Bidder: 5018 - Buchanan and Sons Inc

Line No.	Item Description	Approx. Quantity and Units	Unit Price Dollars Cts	Bid Amount Dollars Ct
0221	6096000000-E SEED FOR SUPPLEMENTAL SEEDING	250.000 LB	3.15000	787.50
0222	6108000000-E FERTILIZER TOPDRESSING	5.750 TON	1,050.00000	6,037.50
0223	6111000000-E IMPERVIOUS DIKE	300.000 LF	65.00000	19,500.00
0224	6114500000-N SPECIALIZED HAND MOWING	20.000 MHR	45.00000	900.00
0225	6117000000-N RESPONSE FOR EROSION CONTROL	50.000 EA	105.00000	5,250.00
0226	6117500000-N CONCRETE WASHOUT STRUCTURE	13.000 EA	2,100.00000	27,300.00
0227	6123000000-E REFORESTATION	5.100 ACR	3,450.00000	17,595.00
0228	6126000000-E STREAMBANK REFORESTATION	0.310 ACR	3,450.00000	1,069.50
0229	6132000000-N GENERIC EROSION CONTROL ITEM FABRIC INSERT INLET PROTECTION DEVICE CLEANOUT	86.000 EA	185.00000	15,910.00
0230	6132000000-N GENERIC EROSION CONTROL ITEM FABRIC INSERT INLET PROTECTION DEVICE	43.000 EA	265.00000	11,395.00
0231	7048500000-E PEDESTRIAN SIGNAL HEAD (16", 1SECTION W/COUNTDOWN)	14.000 EA	1,000.00000	14,000.00

Contract ID: C204130

Project(s): STATE FUNDED

Letting Date: 11-20-18 Call Order: 002

Bidder: 5018 - Buchanan and Sons Inc

Line No.	Item Description	Approx. Quantity and Units	Unit Price Dollars Cts	Bid Amount Dollars Ct
0232	7060000000-E SIGNAL CABLE	13,955.000	3.70000	51,633.50
		LF		
0233	7120000000-E VEHICLE SIGNAL HEAD (12", 3 SECTION)	45.000	1,020.00000	45,900.00
		EA		
0234	7132000000-E VEHICLE SIGNAL HEAD (12", 4 SECTION)	10.000	1,110.00000	11,100.00
		EA		
0235	7144000000-E VEHICLE SIGNAL HEAD (12", 5 SECTION)	14.000	1,550.00000	21,700.00
		EA		
0236	7264000000-E MESSENGER CABLE (3/8")	1,085.000	4.85000	5,262.25
		LF		
0237	7300000000-E UNPAVED TRENCHING (***** (1, 2"))	3,015.000	7.95000	23,969.25
		LF		
0238	7301000000-E DIRECTIONAL DRILL (***** (2, 2"))	1,905.000	18.75000	35,718.75
		LF		
0239	7324000000-N JUNCTION BOX (STANDARD SIZE)	55.000	397.00000	21,835.00
		EA		
0240	7360000000-N WOOD POLE	4.000	1,110.00000	4,440.00
		EA		
0241	7372000000-N GUY ASSEMBLY	7.000	570.00000	3,990.00
		EA		
0242	7444000000-E INDUCTIVE LOOP SAWCUT	5,200.000	8.50000	44,200.00
		LF		
0243	7456000000-E LEAD-IN CABLE (***** (14-2)	13,000.000	2.00000	26,000.00
		LF		

Contract ID: C204130

Project(s): STATE FUNDED

Letting Date: 11-20-18 Call Order: 002

Bidder: 5018 - Buchanan and Sons Inc

Line No.	Item Description	Approx. Quantity and Units	Unit Price Dollars Cts	Bid Amount Dollars Ct
0244	7481000000-N SITE SURVEY	3.000	851.00000	2,553.00
		EA		
0245	7481200000-N LUMINAIRE ARM FOR VIDEO SYSTEM	12.000	740.00000	8,880.00
		EA		
0246	7481240000-N CAMERA WITHOUT INTERNAL LOOP EMULATOR PROCESSING UNIT	12.000	3,350.00000	40,200.00
		EA		
0247	7481260000-N EXTERNAL LOOP EMULATOR PRO- CESSING UNIT	3.000	9,550.00000	28,650.00
		EA		
0248	7481280000-N RELOCATE CAMERA SENSOR UNIT	9.000	910.00000	8,190.00
		EA		
0249	7575142000-N 900MHZ SERIAL SPREAD SPECTRUM RADIO	4.000	3,600.00000	14,400.00
		EA		
0250	7588000000-N METAL POLE WITH SINGLE MAST ARM	16.000	19,900.00000	318,400.00
		EA		
0251	7613000000-N SOIL TEST	16.000	1,600.00000	25,600.00
		EA		
0252	7614100000-E DRILLED PIER FOUNDATION	144.000	1,000.00000	144,000.00
		CY		
0253	7631000000-N MAST ARM WITH METAL POLE DE- SIGN	16.000	400.00000	6,400.00
		EA		
0254	7636000000-N SIGN FOR SIGNALS	18.000	510.00000	9,180.00
		EA		
0255	7642200000-N TYPE II PEDESTAL WITH FOUND- ATION	14.000	1,760.00000	24,640.00
		EA		

Contract ID: C204130 Project(s): STATE FUNDED

Letting Date: 11-20-18 Call Order: 002

Bidder: 5018 - Buchanan and Sons Inc

Line No.	Item Description	Approx. Quantity and Units	Unit Price Dollars Cts	Bid Amount Dollars Ct
0256	7684000000-N SIGNAL CABINET FOUNDATION	4.000 EA	1,365.00000	5,460.00
0257	7696000000-N CONTROLLERS WITH CABINET (*****) (TYPE 2070E, BASE MOUNTED)	4.000 EA	15,000.00000	60,000.00
0258	7744000000-N DETECTOR CARD (TYPE 170)	34.000 EA	130.00000	4,420.00
0259	7901000000-N CABINET BASE EXTENDER	4.000 EA	625.00000	2,500.00
0260	7960000000-N METAL POLE FOUNDATION REMOVAL	1.000 EA	2,300.00000	2,300.00
0261	7972000000-N METAL POLE REMOVAL	1.000 EA	1,700.00000	1,700.00
0262	7980000000-N GENERIC SIGNAL ITEM PROTECTIVE COATING FOR PUSHBUTTON POST (BLACK)	14.000 EA	230.00000	3,220.00
0263	7980000000-N GENERIC SIGNAL ITEM PROTECTIVE COATING FOR SINGLE MAST ARM POLE (BLACK)	16.000 EA	2,850.00000	45,600.00
Section 0001 Total				13,013,978.40

Section 0002 CULVERT ITEMS

Alt Group

0264	8126000000-N CULVERT EXCAVATION, STA ***** (19+20.00 -L-)	LUMP	LUMP	11,000.00
------	---	------	------	-----------

Contract ID: C204130

Project(s): STATE FUNDED

Letting Date: 11-20-18 Call Order: 002

Bidder: 5018 - Buchanan and Sons Inc

Line No.	Item Description	Approx. Quantity and Units	Unit Price Dollars Cts	Bid Amount Dollars Ct
0265	8133000000-E FOUNDATION CONDITIONING MATERIAL, BOX CULVERT	16.000 TON	86.50000	1,384.00
0266	8196000000-E CLASS A CONCRETE (CULVERT)	41.700 CY	1,500.00000	62,550.00
0267	8245000000-E REINFORCING STEEL (CULVERT)	3,911.000 LB	1.70000	6,648.70
Section 0002 Total				81,582.70
Section 0003 WALL ITEMS				
Alt Group				
0268	8802014000-E SOLDIER PILE RETAINING WALLS	935.000 SF	170.00000	158,950.00
Section 0003 Total				158,950.00
Section 0004 STRUCTURE ITEMS				
Alt Group				
0269	8017000000-N CONSTRUCTION, MAINTENANCE, & REMOVAL OF TEMP ACCESS AT STA ***** (14+94.00 -L-)	LUMP	LUMP	62,500.00
0270	8035000000-N REMOVAL OF EXISTING STRUCTURE AT STATION ***** (14+94.00 -L-)	LUMP	LUMP	49,600.00
0271	8065000000-N ASBESTOS ASSESSMENT	LUMP	LUMP	2,500.00

Contract ID: C204130

Project(s): STATE FUNDED

Letting Date: 11-20-18 Call Order: 002

Bidder: 5018 - Buchanan and Sons Inc

Line No.	Item Description	Approx. Quantity and Units	Unit Price Dollars Cts	Bid Amount Dollars Ct
0272	8121000000-N UNCLASSIFIED STRUCTURE EXCAVATION AT STATION ***** (14+94.00 -L-)	LUMP	LUMP	10,000.00
0273	8175000000-E CLASS AA CONCRETE (BRIDGE)	43.700 CY	851.00000	37,188.70
0274	8182000000-E CLASS A CONCRETE (BRIDGE)	59.400 CY	851.00000	50,549.40
0275	8210000000-N BRIDGE APPROACH SLABS, STATION***** (14+94.00 -L-)	LUMP	LUMP	29,500.00
0276	8217000000-E REINFORCING STEEL (BRIDGE)	10,862.000 LB	1.70000	18,465.40
0277	8224000000-E EPOXY COATED REINFORCING STEEL (BRIDGE)	1,092.000 LB	1.70000	1,856.40
0278	8328200000-E PILE DRIVING EQUIPMENT SETUP FOR *** STEEL PILES (HP 12 X 53)	14.000 EA	360.00000	5,040.00
0279	8364000000-E HP12X53 STEEL PILES	980.000 LF	91.00000	89,180.00
0280	8482000000-E THREE BAR METAL RAIL	92.200 LF	295.00000	27,199.00
0281	8505000000-E VERTICAL CONCRETE BARRIER RAIL	100.000 LF	182.00000	18,200.00
0282	8608000000-E RIP RAP CLASS II (2'-0" THICK)	285.000 TON	23.00000	6,555.00

Contract ID: C204130

Project(s): STATE FUNDED

Letting Date: 11-20-18 Call Order: 002

Bidder: 5018 - Buchanan and Sons Inc

Line No.	Item Description	Approx. Quantity and Units	Unit Price Dollars Cts	Bid Amount Dollars Ct
0283	8622000000-E GEOTEXTILE FOR DRAINAGE	320.000	8.00000	2,560.00
		SY		
0284	8657000000-N ELASTOMERIC BEARINGS	LUMP	LUMP	5,500.00
0285	8753200000-E 3'-0" X 3'-3" PRESTRESSED CONCBOX BEAMS	1,100.000	329.00000	361,900.00
		LF		
	Section 0004 Total			778,293.90
	Bid Total			14,032,805.00

NON-COLLUSION AND DEBARMENT CERTIFICATION

The bidder certifies that neither he, nor any official, agent or employee of the bidder has entered into any agreement, participated in any collusion, or otherwise taken any action which is in restraint of free competitive bidding in connection with this bid, and that the bidder intends to do the work with its own bonafide employees or subcontractors and is not bidding for the benefit of another contractor. In addition, submitting this electronic bid constitutes the bidder's certification of Status under penalty of perjury under the laws of the United States and in accordance with the Debarment Certification on file with the Department.

By submitting this bid, the bidder certifies to the best of his knowledge and belief that he and his principals:

- a. Are not presently debarred, suspended, proposed for debarment, declared ineligible, or voluntarily excluded from covered transactions by any Federal department or agency;
- b. Have not within a three-year period preceding this proposal been convicted of or had a civil judgment rendered against them for commission of fraud or a criminal offense in connection with obtaining, attempting to obtain, or performing a public (Federal, State or local) transaction or contract under a public transaction; violation of Federal or State antitrust statutes or commission of embezzlement, theft, forgery, bribery, falsification or destruction of records; making false statements; or receiving stolen property;
- c. Are not presently indicted for or otherwise criminally or civilly charged by a governmental entity (Federal, State or local) with commission of any of the offenses enumerated in paragraph b. of this certification; and
- d. Have not within a three-year period preceding this proposal had one or more public transactions (Federal, State or local) terminated for cause or default.

Where the prospective bidder is unable to certify to any of the statements in this certification, the bidder shall submit an explanation in the blanks provided herein. The explanation will not necessarily result in denial of participation in a contract.

Explanation:
NOT ANSWERED
NOT ANSWERED
NOT ANSWERED
NOT ANSWERED

If the prequalified bidder's status changes, he shall immediately submit a new fully executed non-collusion affidavit and debarment certification with an explanation of the change to the Contract Office prior to submitting the bid.

Failure to furnish a certification or an explanation will be grounds for rejection of a bid

AWARD LIMITS ON MULTIPLE PROJECTS

By answering YES to this statement, the bidder acknowledges that they are using the award limits on multiple projects. No

A bidder who desires to bid on more than one project on which bids are to be opened on the same date, and who also desires to avoid receiving an award of more projects than he is equipped to handle, may bid on any number of projects but may limit the total amount of work awarded to him on selected projects by completing the AWARD LIMITS ON MULTIPLE PROJECTS.

The Award Limits on Multiple Projects must be filled in on each project bid for which the Bidder desires protection.

It is the desire of the Bidder to be awarded contracts, the value of which will not exceed a total of NOT ANSWERED for those projects indicated herein, for which bids will be opened on (MM/DD/YY)

The Award Limits shall apply to the following projects:

Contract Number	County
NOT ANSWERED	
NOT ANSWERED	
NOT ANSWERED	
NOT ANSWERED	
NOT ANSWERED	
NOT ANSWERED	

It is agreed that if I am (we are) the low Bidder(s) on indicated projects, the total value of which is more than the above stipulated award limits, the Board of Transportation will award me (us) projects from among those indicated that have a total value not to exceed the award limit and will result in the lowest total bids to the Department of Transportation.

DBE COMMITMENT ITEMS

PROPOSAL: C204130
 LETTING: L181120 CALL: 002
 VENDOR: 5018 Buchanan and Sons Inc

LINE NO.	ITEM NO.	ITEM DESC.	UNIT TYPE	SUBCONTRACTOR QUANTITY	SUBCONTRACTOR UNIT PRICE	EXTENDED AMOUNT
----------	----------	------------	-----------	------------------------	--------------------------	-----------------

DBE SUBCONTRACTOR: 9615 OWLE CONTAINER INCORPORATED

Will Use Quote: Yes

0001	0000100000-N	MOBILIZATION	LS	1.000	48100.00000	48100.00
0011	0199000000-E	TEMPORARY	SH SF	200.000	100.00000	20000.00
0264	8126000000-N	CULV EXCAV @	LS	1.000	9000.00000	9000.00
0265	8133000000-E	FND CONDIT	M TON	16.000	76.00000	1216.00
0266	8196000000-E	CLASS A CONC	CY	41.700	1300.00000	54210.00
0267	8245000000-E	REINF STEEL	LB	3911.000	1.50000	5866.50
0268	8802014000-E	SOLDIER PILE	SF	935.000	150.00000	140250.00
0269	8017000000-N	CM&R TEMP	AC LS	1.000	55000.00000	55000.00
0270	8035000000-N	REMV EXIST	S LS	1.000	43700.00000	43700.00
0271	8065000000-N	ASBESTOS ASS	LS	1.000	2200.00000	2200.00
0272	8121000000-N	UNCL STR EXC	LS	1.000	7900.00000	7900.00
0273	8175000000-E	CLASS AA CON	CY	43.700	750.00000	32775.00
0274	8182000000-E	CLASS A CONC	CY	59.400	750.00000	44550.00
0275	8210000000-N	BRG APPR SLA	LS	1.000	25700.00000	25700.00
0276	8217000000-E	REINF STEEL	LB	10862.000	1.50000	16293.00
0277	8224000000-E	EPOXY COAT R	LB	1092.000	1.50000	1638.00
0278	8328200000-E	PILE DRV EQU	EA	14.000	310.00000	4340.00
0279	8364000000-E	HP12X53 PILE	LF	980.000	80.00000	78400.00
0280	8482000000-E	THREE BAR ME	LF	92.200	260.00000	23972.00
0281	8505000000-E	VERT CONC BA	LF	100.000	160.00000	16000.00
0282	8608000000-E	RIP RAP II (TON	285.000	20.00000	5700.00
0283	8622000000-E	GEOTEXTILE F	SY	320.000	7.00000	2240.00
0284	8657000000-N	ELASTOMERIC	LS	1.000	4800.00000	4800.00
0285	8753200000-E	3'-0"X 3'-3"	LF	1100.000	290.00000	319000.00

DBE COMMITMENT TOTAL FOR SUBCONTRACTOR: 962,850.50

DBE COMMITMENT TOTAL FOR VENDOR (SubContractor) 962,850

DBE SUBCONTRACTOR: 6101 DMJ'S INCORPORATED

Will Use Quote: Yes

0217	6084000000-E	SEEDING AND	ACR	10.500	2100.00000	22050.00
0218	6087000000-E	MOWING	ACR	6.500	200.00000	1300.00
0219	6090000000-E	SEED FOR REP	LB	150.000	2.00000	300.00
0220	6093000000-E	FERT FOR REP	TON	0.500	800.00000	400.00
0221	6096000000-E	SEED FOR SUP	LB	250.000	3.00000	750.00
0222	6108000000-E	FERTILIZER T	TON	5.750	1000.00000	5750.00
0224	6114500000-N	SPECIALIZED	MHR	20.000	40.00000	800.00
0225	6117000000-N	RESPONSE FOR	EA	50.000	100.00000	5000.00
0227	6123000000-E	REFORESTATIO	ACR	5.100	3000.00000	15300.00
0228	6126000000-E	STREAMBANK R	ACR	0.310	3000.00000	930.00

LINE NO.	ITEM NO.	ITEM DESC.	UNIT TYPE	SUBCONTRACTOR QUANTITY	SUBCONTRACTOR UNIT PRICE	EXTENDED AMOUNT
----------	----------	------------	-----------	------------------------	--------------------------	-----------------

DBE COMMITMENT TOTAL FOR SUBCONTRACTOR: 52,580.00
DBE COMMITMENT TOTAL FOR VENDOR (SubContractor) 52,580.

TOTAL DBE COMMITMENT FOR VENDOR: Entered: 7.24% or 1015430.50
Required: 7.00% or 982296.35
<GOAL MET>

THIS PROPOSAL CONTAINS THE FOLLOWING ERRORS/WARNINGS (IF ANY)

This Bid contains 2 amendment files

00001 11-05-18 MODIFY ITEMS
00002 11-13-18 MODIFY ITEM

Electronic Bid Submission

By submitting this bid electronically, I hereby acknowledge that all requirements included in the hard copy proposal, addendum, amendments, plans, standard specifications, supplemental specifications and special provisions are part of the bid and contract. Further, I acknowledge that I have read, understand, accept, acknowledge and agree to comply with all statements in this electronic bid.

I Hereby certify that I have the authority to submit this bid.

Signature

Agency

Date

Contract Item Sheets For C204130

Line #	ItemNumber	Sec #	Description	Quantity Unit	Unit Bid Price	Amount Bid
ROADWAY ITEMS						
0001	0000100000-N	800	MOBILIZATION	Lump Sum LS	725,000.00	725,000.00
0002	0000400000-N	801	CONSTRUCTION SURVEYING	Lump Sum LS	180,000.00	180,000.00
0003	0015000000-N	205	SEALING ABANDONED WELLS	1 EA	2,303.66	2,303.66
0004	0030000000-N	SP	TYPE II MODIFIED APPROACH FILL, STATION ***** (14+94.00 -L-)	Lump Sum LS	15,000.00	15,000.00
0005	0043000000-N	226	GRADING	Lump Sum LS	910,000.00	910,000.00
0006	0050000000-E	226	SUPPLEMENTARY CLEARING & GRUB- BING	2 ACR	8,400.00	16,800.00
0007	0057000000-E	226	UNDERCUT EXCAVATION	1,050 CY	20.00	21,000.00
0008	0134000000-E	240	DRAINAGE DITCH EXCAVATION	3,630 CY	21.50	78,045.00
0009	0195000000-E	265	SELECT GRANULAR MATERIAL	3,300 CY	65.00	214,500.00
0010	0196000000-E	270	GEOTEXTILE FOR SOIL STABILIZA- TION	3,500 SY	1.90	6,650.00
0011	0199000000-E	SP	TEMPORARY SHORING	200 SF	114.00	22,800.00
0012	0223000000-E	275	ROCK PLATING	200 SY	72.00	14,400.00
0013	0225000000-E	SP	REINFORCED SOIL SLOPES	130 SY	190.00	24,700.00
0014	0318000000-E	300	FOUNDATION CONDITIONING MATE- RIAL, MINOR STRUCTURES	1,441 TON	50.00	72,050.00
0015	0320000000-E	300	FOUNDATION CONDITIONING GEO- TEXTILE	5,114 SY	4.00	20,456.00
0016	0335200000-E	305	15" DRAINAGE PIPE	248 LF	65.20	16,169.60
0017	0335400000-E	305	24" DRAINAGE PIPE	28 LF	75.00	2,100.00
0018	0335500000-E	305	30" DRAINAGE PIPE	112 LF	92.30	10,337.60
0019	0335850000-E	305	*** DRAINAGE PIPE ELBOWS (15")	2 EA	545.00	1,090.00

Contract Item Sheets For C204130

Line #	ItemNumber	Sec #	Description	Quantity Unit	Unit Bid Price	Amount Bid
0020	0366000000-E	310	15" RC PIPE CULVERTS, CLASS III	396 LF	60.50	23,958.00
0021	0372000000-E	310	18" RC PIPE CULVERTS, CLASS III	400 LF	72.00	28,800.00
0022	0378000000-E	310	24" RC PIPE CULVERTS, CLASS III	40 LF	89.50	3,580.00
0023	0390000000-E	310	36" RC PIPE CULVERTS, CLASS III	88 LF	109.00	9,592.00
0024	0402000000-E	310	48" RC PIPE CULVERTS, CLASS III	608 LF	182.00	110,656.00
0025	0448000000-E	310	***** RC PIPE CULVERTS, CLASS IV (48")	92 LF	340.00	31,280.00
0026	0448200000-E	310	15" RC PIPE CULVERTS, CLASS IV	2,528 LF	76.10	192,380.80
0027	0448300000-E	310	18" RC PIPE CULVERTS, CLASS IV	376 LF	84.00	31,584.00
0028	0448400000-E	310	24" RC PIPE CULVERTS, CLASS IV	304 LF	115.00	34,960.00
0029	0448500000-E	310	30" RC PIPE CULVERTS, CLASS IV	544 LF	116.50	63,376.00
0030	0448600000-E	310	36" RC PIPE CULVERTS, CLASS IV	836 LF	170.00	142,120.00
0031	0448700000-E	310	42" RC PIPE CULVERTS, CLASS IV	388 LF	171.00	66,348.00
0032	0588000000-E	310	18" CS PIPE CULVERTS, 0.064" THICK	36 LF	73.00	2,628.00
0033	0594000000-E	310	24" CS PIPE CULVERTS, 0.064" THICK	12 LF	168.00	2,016.00
0034	0636000000-E	310	*** CS PIPE ELBOWS, ***** THICK (18", 0.064")	1 EA	480.00	480.00
0035	0986000000-E	SP	GENERIC PIPE ITEM 15" CURED IN PLACE PIPE	106 LF	132.00	13,992.00
0036	0986000000-E	SP	GENERIC PIPE ITEM 18" CURED IN PLACE PIPE	255 LF	177.00	45,135.00

Line #	ItemNumber	Sec #	Description	Quantity Unit	Unit Bid Price	Amount Bid
0037	0986000000-E	SP	GENERIC PIPE ITEM 24" CURED IN PLACE PIPE	155 LF	268.00	41,540.00
0038	0986000000-E	SP	GENERIC PIPE ITEM 30" CURED IN PLACE PIPE	185 LF	285.00	52,725.00
0039	0995000000-E	340	PIPE REMOVAL	1,746 LF	14.50	25,317.00
0040	1099500000-E	505	SHALLOW UNDERCUT	150 CY	15.50	2,325.00
0041	1099700000-E	505	CLASS IV SUBGRADE STABILIZATION	250 TON	42.00	10,500.00
0042	1121000000-E	520	AGGREGATE BASE COURSE	516 TON	39.00	20,124.00
0043	1220000000-E	545	INCIDENTAL STONE BASE	2,050 TON	49.00	100,450.00
0044	1275000000-E	600	PRIME COAT	175 GAL	30.00	5,250.00
0045	1297000000-E	607	MILLING ASPHALT PAVEMENT, **** DEPTH (1-1/2")	2,590 SY	9.00	23,310.00
0046	1330000000-E	607	INCIDENTAL MILLING	5,100 SY	12.00	61,200.00
0047	1491000000-E	610	ASPHALT CONC BASE COURSE, TYPE B25.0C	7,050 TON	112.00	789,600.00
0048	1503000000-E	610	ASPHALT CONC INTERMEDIATE COURSE, TYPE I19.0C	4,810 TON	112.00	538,720.00
0049	1523000000-E	610	ASPHALT CONC SURFACE COURSE, TYPE S9.5C	9,610 TON	106.00	1,018,660.00
0050	1575000000-E	620	ASPHALT BINDER FOR PLANT MIX	1,130 TON	864.00	976,320.00
0051	1693000000-E	654	ASPHALT PLANT MIX, PAVEMENT REPAIR	200 TON	250.00	50,000.00
0052	2022000000-E	815	SUBDRAIN EXCAVATION	67.2 CY	25.00	1,680.00
0053	2026000000-E	815	GEOTEXTILE FOR SUBSURFACE DRAINS	200 SY	6.50	1,300.00
0054	2036000000-E	815	SUBDRAIN COARSE AGGREGATE	33.6 CY	95.00	3,192.00

Line #	ItemNumber	Sec #	Description	Quantity Unit	Unit Bid Price	Amount Bid
0055	2044000000-E	815	6" PERFORATED SUBDRAIN PIPE	200 LF	18.00	3,600.00
0056	2070000000-N	815	SUBDRAIN PIPE OUTLET	1 EA	580.00	580.00
0057	2077000000-E	815	6" OUTLET PIPE	6 LF	40.50	243.00
0058	2253000000-E	840	PIPE COLLARS	3.148 CY	2,636.00	8,298.13
0059	2264000000-E	840	PIPE PLUGS	0.13 CY	13,152.00	1,709.76
0060	2275000000-E	SP	FLOWABLE FILL	52 CY	320.00	16,640.00
0061	2286000000-N	840	MASONRY DRAINAGE STRUCTURES	101 EA	2,435.00	245,935.00
0062	2308000000-E	840	MASONRY DRAINAGE STRUCTURES	61.1 LF	245.00	14,969.50
0063	2364000000-N	840	FRAME WITH TWO GRATES, STD 840.16	25 EA	750.00	18,750.00
0064	2366000000-N	840	FRAME WITH TWO GRATES, STD 840.24	8 EA	700.00	5,600.00
0065	2367000000-N	840	FRAME WITH TWO GRATES, STD 840.29	4 EA	700.00	2,800.00
0066	2374000000-N	840	FRAME WITH GRATE & HOOD, STD 840.03, TYPE ** (E)	10 EA	820.00	8,200.00
0067	2374000000-N	840	FRAME WITH GRATE & HOOD, STD 840.03, TYPE ** (F)	16 EA	820.00	13,120.00
0068	2374000000-N	840	FRAME WITH GRATE & HOOD, STD 840.03, TYPE ** (G)	25 EA	830.00	20,750.00
0069	2396000000-N	840	FRAME WITH COVER, STD 840.54	18 EA	610.00	10,980.00
0070	2451000000-N	852	CONCRETE TRANSITIONAL SECTION FOR DROP INLET	22 EA	950.00	20,900.00
0071	2538000000-E	846	***-*** CONCRETE CURB & GUTTER (2'-9")	460 LF	34.20	15,732.00
0072	2542000000-E	846	1'-6" CONCRETE CURB & GUTTER	2,800 LF	24.25	67,900.00

Line #	ItemNumber	Sec #	Description	Quantity Unit	Unit Bid Price	Amount Bid
0073	2549000000-E	846	2'-6" CONCRETE CURB & GUTTER	11,560 LF	30.75	355,470.00
0074	2556000000-E	846	SHOULDER BERM GUTTER	48 LF	52.50	2,520.00
0075	2570000000-N	SP	MODIFIED CONCRETE FLUME	1 EA	2,625.00	2,625.00
0076	2591000000-E	848	4" CONCRETE SIDEWALK	4,600 SY	50.50	232,300.00
0077	2605000000-N	848	CONCRETE CURB RAMPS	39 EA	2,000.00	78,000.00
0078	2612000000-E	848	6" CONCRETE DRIVEWAY	714 SY	79.50	56,763.00
0079	2619000000-E	850	4" CONCRETE PAVED DITCH	50 SY	73.50	3,675.00
0080	2655000000-E	852	5" MONOLITHIC CONCRETE ISLANDS (KEYED IN)	1,600 SY	73.50	117,600.00
0081	2657000000-E	852	*** MONOLITHIC CONCRETE MEDIAN (****) (5-1/2", KEYED IN)	20 SY	85.00	1,700.00
0082	2738000000-E	SP	GENERIC PAVING ITEM REINFORCED CONCRETE DRIVEWAY	259 SY	90.00	23,310.00
0083	2761000000-E	848	GENERIC PAVING ITEM 8" CONCRETE DRIVEWAY	90 SY	120.00	10,800.00
0084	2800000000-N	858	ADJUSTMENT OF CATCH BASINS	10 EA	1,000.00	10,000.00
0085	2830000000-N	858	ADJUSTMENT OF MANHOLES	4 EA	1,550.00	6,200.00
0086	2845000000-N	858	ADJUSTMENT OF METER BOXES OR VALVE BOXES	7 EA	995.00	6,965.00
0087	2860000000-N	859	CONVERT EXISTING CATCH BASIN TO JUNCTION BOX	1 EA	2,200.00	2,200.00
0088	2905000000-N	859	CONVERT EXISTING DROP INLET TO JUNCTION BOX	2 EA	2,200.00	4,400.00
0089	2995000000-N	SP	GENERIC DRAINAGE ITEM CONVERT EXISTING CATCH BASIN TO TRAFFIC BEARING JUNCTION BOX	2 EA	1,700.00	3,400.00
0090	3030000000-E	862	STEEL BEAM GUARDRAIL	2,000 LF	18.90	37,800.00

Contract Item Sheets For C204130

Line #	ItemNumber	Sec #	Description	Quantity Unit	Unit Bid Price	Amount Bid
0091	3045000000-E	862	STEEL BEAM GUARDRAIL, SHOP CURVED	112.5 LF	23.10	2,598.75
0092	3150000000-N	862	ADDITIONAL GUARDRAIL POSTS	15 EA	47.25	708.75
0093	3195000000-N	862	GUARDRAIL END UNITS, TYPE AT-1	1 EA	750.00	750.00
0094	3210000000-N	862	GUARDRAIL END UNITS, TYPE CAT-1	6 EA	700.00	4,200.00
0095	3215000000-N	SP	GUARDRAIL ANCHOR UNITS, TYPE III	7 EA	2,100.00	14,700.00
0096	3287000000-N	SP	GUARDRAIL END UNITS, TYPE TL-3	6 EA	3,300.00	19,800.00
0097	3288000000-N	SP	GUARDRAIL END UNITS, TYPE TL-2	4 EA	3,520.00	14,080.00
0098	3360000000-E	863	REMOVE EXISTING GUARDRAIL	1,555 LF	1.15	1,788.25
0099	3380000000-E	862	TEMPORARY STEEL BEAM GUARDRAIL	287.5 LF	13.60	3,910.00
0100	3389150000-N	SP	TEMPORARY GUARDRAIL END UNITS, TYPE ***** (TL-3)	1 EA	3,700.00	3,700.00
0101	3435000000-N	SP	GENERIC GUARDRAIL ITEM GUARDRAIL POST CAPS	161 EA	45.40	7,309.40
0102	3533000000-E	866	CHAIN LINK FENCE, *** FABRIC (60")	73 LF	20.45	1,492.85
0103	3536000000-E	866	CHAIN LINK FENCE, 48" FABRIC	382 LF	15.90	6,073.80
0104	3539000000-E	866	METAL LINE POSTS FOR *** CHAIN LINK FENCE (60")	7 EA	85.50	598.50
0105	3542000000-E	866	METAL LINE POSTS FOR 48" CHAIN LINK FENCE	32 EA	73.75	2,360.00
0106	3545000000-E	866	METAL TERMINAL POSTS FOR *** CHAIN LINK FENCE (60")	4 EA	230.00	920.00
0107	3548000000-E	866	METAL TERMINAL POSTS FOR 48" CHAIN LINK FENCE	4 EA	170.00	680.00

Line #	ItemNumber	Sec #	Description	Quantity Unit	Unit Bid Price	Amount Bid
0108	3575000000-E	SP	GENERIC FENCING ITEM WALL MOUNTED PEDESTRIAN HANDRAIL	182 LF	170.00	30,940.00
0109	3628000000-E	876	RIP RAP, CLASS I	1,176 TON	80.50	94,668.00
0110	3635000000-E	876	RIP RAP, CLASS II	50 TON	72.00	3,600.00
0111	3649000000-E	876	RIP RAP, CLASS B	332 TON	82.00	27,224.00
0112	3656000000-E	876	GEOTEXTILE FOR DRAINAGE	5,083 SY	2.75	13,978.25
0113	4048000000-E	902	REINFORCED CONCRETE SIGN FOUN- DATIONS	3 CY	735.00	2,205.00
0114	4054000000-E	902	PLAIN CONCRETE SIGN FOUNDA- TIONS	1 CY	735.00	735.00
0115	4057000000-E	SP	OVERHEAD FOOTING	49 CY	1,155.00	56,595.00
0116	4060000000-E	903	SUPPORTS, BREAKAWAY STEEL BEAM	3,159 LB	6.30	19,901.70
0117	4066000000-E	903	SUPPORTS, SIMPLE STEEL BEAM	415 LB	6.30	2,614.50
0118	4072000000-E	903	SUPPORTS, 3-LB STEEL U-CHANNEL	2,250 LF	8.00	18,000.00
0119	4082100000-N	906	SUPPORTS, OVERHEAD SIGN STRUC- TURE AT STA ***** (13+25 -LPD-)	Lump Sum LS	85,000.00	85,000.00
0120	4082100000-N	906	SUPPORTS, OVERHEAD SIGN STRUC- TURE AT STA ***** (69+00 -L-)	Lump Sum LS	75,000.00	75,000.00
0121	4096000000-N	904	SIGN ERECTION, TYPE D	13 EA	125.00	1,625.00
0122	4102000000-N	904	SIGN ERECTION, TYPE E	118 EA	74.00	8,732.00
0123	4108000000-N	904	SIGN ERECTION, TYPE F	13 EA	155.00	2,015.00
0124	4110000000-N	904	SIGN ERECTION, TYPE *** (GROUND MOUNTED) (A)	4 EA	735.00	2,940.00
0125	4116100000-N	904	SIGN ERECTION, RELOCATE TYPE **** (GROUND MOUNTED) (A)	1 EA	735.00	735.00

Contract Item Sheets For C204130

Line #	ItemNumber	Sec #	Description	Quantity Unit	Unit Bid Price	Amount Bid
0126	4116100000-N	904	SIGN ERECTION, RELOCATE TYPE **** (GROUND MOUNTED) (B)	1 EA	735.00	735.00
0127	4116100000-N	904	SIGN ERECTION, RELOCATE TYPE **** (GROUND MOUNTED) (D)	2 EA	116.00	232.00
0128	4116100000-N	904	SIGN ERECTION, RELOCATE TYPE **** (GROUND MOUNTED) (E)	2 EA	74.00	148.00
0129	4116100000-N	904	SIGN ERECTION, RELOCATE TYPE **** (GROUND MOUNTED) (F)	2 EA	165.00	330.00
0130	4138000000-N	907	DISPOSAL OF SUPPORT, STEEL BEAM	1 EA	210.00	210.00
0131	4152000000-N	907	DISPOSAL OF SIGN SYSTEM, STEEL BEAM	1 EA	230.00	230.00
0132	4155000000-N	907	DISPOSAL OF SIGN SYSTEM, U- CHANNEL	80 EA	1.15	92.00
0133	4192000000-N	907	DISPOSAL OF SUPPORT, U-CHANNEL	1 EA	1.15	1.15
0134	4360000000-N	SP	GENERIC SIGNING ITEM DISPOSAL OF SIGN SYSTEM ON SPAN WIRE	1 EA	2,300.00	2,300.00
0135	4400000000-E	1110	WORK ZONE SIGNS (STATIONARY)	680 SF	14.30	9,724.00
0136	4405000000-E	1110	WORK ZONE SIGNS (PORTABLE)	288 SF	32.10	9,244.80
0137	4410000000-E	1110	WORK ZONE SIGNS (BARRICADE MOUNTED)	57 SF	11.50	655.50
0138	4415000000-N	1115	FLASHING ARROW BOARD	1 EA	2,500.00	2,500.00
0139	4430000000-N	1130	DRUMS	555 EA	63.00	34,965.00
0140	4435000000-N	1135	CONES	80 EA	24.00	1,920.00
0141	4445000000-E	1145	BARRICADES (TYPE III)	64 LF	31.00	1,984.00
0142	4480000000-N	1165	TMA	1 EA	50,000.00	50,000.00

Line #	ItemNumber	Sec #	Description	Quantity Unit	Unit Bid Price	Amount Bid
0143	4510000000-N	1190	LAW ENFORCEMENT	32 HR	68.00	2,176.00
0144	4650000000-N	1251	TEMPORARY RAISED PAVEMENT MARKERS	8 EA	115.00	920.00
0145	4685000000-E	1205	THERMOPLASTIC PAVEMENT MARKING LINES (4", 90 MILS)	7,750 LF	0.95	7,362.50
0146	4686000000-E	1205	THERMOPLASTIC PAVEMENT MARKING LINES (4", 120 MILS)	17,551 LF	1.00	17,551.00
0147	4688000000-E	1205	THERMOPLASTIC PAVEMENT MARKING LINES (6", 90 MILS)	975 LF	3.40	3,315.00
0148	4690000000-E	1205	THERMOPLASTIC PAVEMENT MARKING LINES (6", 120 MILS)	419 LF	3.70	1,550.30
0149	4695000000-E	1205	THERMOPLASTIC PAVEMENT MARKING LINES (8", 90 MILS)	1,420 LF	2.30	3,266.00
0150	4697000000-E	1205	THERMOPLASTIC PAVEMENT MARKING LINES (8", 120 MILS)	2,313 LF	3.40	7,864.20
0151	4700000000-E	1205	THERMOPLASTIC PAVEMENT MARKING LINES (12", 90 MILS)	265 LF	3.00	795.00
0152	4710000000-E	1205	THERMOPLASTIC PAVEMENT MARKING LINES (24", 120 MILS)	655 LF	8.00	5,240.00
0153	4721000000-E	1205	THERMOPLASTIC PAVEMENT MARKING CHARACTER (120 MILS)	36 EA	125.00	4,500.00
0154	4725000000-E	1205	THERMOPLASTIC PAVEMENT MARKING SYMBOL (90 MILS)	114 EA	136.00	15,504.00
0155	4726110000-E	1205	HEATED-IN-PLACE THERMOPLASTIC PAVEMENT MARKING SYMBOL (90 MILS)	52 EA	370.00	19,240.00
0156	4770000000-E	1205	COLD APPLIED PLASTIC PAVEMENT MARKING LINES, TYPE ** (4") (IV)	684 LF	3.00	2,052.00
0157	4810000000-E	1205	PAINT PAVEMENT MARKING LINES (4")	46,348 LF	0.30	13,904.40
0158	4820000000-E	1205	PAINT PAVEMENT MARKING LINES (8")	5,877 LF	1.15	6,758.55

Line #	ItemNumber	Sec #	Description	Quantity Unit	Unit Bid Price	Amount Bid
0159	4835000000-E	1205	PAINT PAVEMENT MARKING LINES (24")	1,602 LF	3.40	5,446.80
0160	4840000000-N	1205	PAINT PAVEMENT MARKING CHARACTER	16 EA	65.00	1,040.00
0161	4845000000-N	1205	PAINT PAVEMENT MARKING SYMBOL	162 EA	65.00	10,530.00
0162	4850000000-E	1205	REMOVAL OF PAVEMENT MARKING LINES (4")	343 LF	2.30	788.90
0163	4875000000-N	1205	REMOVAL OF PAVEMENT MARKING SYMBOLS & CHARACTERS	11 EA	85.00	935.00
0164	4895000000-N	SP	GENERIC PAVEMENT MARKING ITEM IN LANE ROUTE SHIELD	1 EA	4,000.00	4,000.00
0165	4900000000-N	1251	PERMANENT RAISED PAVEMENT MARKERS	4 EA	230.00	920.00
0166	4905000000-N	1253	SNOWPLOWABLE PAVEMENT MARKERS	874 EA	32.00	27,968.00
0167	5255000000-N	1413	PORTABLE LIGHTING	Lump Sum LS	111,000.00	111,000.00
0168	5325800000-E	1510	8" WATER LINE	20 LF	116.00	2,320.00
0169	5326000000-E	1510	10" WATER LINE	20 LF	144.00	2,880.00
0170	5326200000-E	1510	12" WATER LINE	2,045 LF	134.50	275,052.50
0171	5329000000-E	1510	DUCTILE IRON WATER PIPE FITTINGS	14,400 LB	8.00	115,200.00
0172	5558000000-E	1515	12" VALVE	4 EA	4,950.00	19,800.00
0173	5571000000-E	1515	*** TAPPING SLEEVE & VALVE (1")	3 EA	1,750.00	5,250.00
0174	5588000000-E	1515	** AIR RELEASE VALVE (12")	2 EA	6,750.00	13,500.00
0175	5648000000-N	1515	RELOCATE WATER METER	6 EA	2,400.00	14,400.00
0176	5666000000-N	1515	FIRE HYDRANT	2 EA	5,500.00	11,000.00
0177	5672000000-N	1515	RELOCATE FIRE HYDRANT	1 EA	2,300.00	2,300.00

Line #	ItemNumber	Sec #	Description	Quantity Unit	Unit Bid Price	Amount Bid
0178	5673000000-E	1515	FIRE HYDRANT LEG	28 LF	182.00	5,096.00
0179	5686500000-E	1515	WATER SERVICE LINE	89 LF	40.00	3,560.00
0180	5691100000-E	1520	4" SANITARY GRAVITY SEWER	134 LF	100.00	13,400.00
0181	5691300000-E	1520	8" SANITARY GRAVITY SEWER	1,503 LF	180.00	270,540.00
0182	5691500000-E	1520	12" SANITARY GRAVITY SEWER	2,496 LF	220.00	549,120.00
0183	5691600000-E	1520	16" SANITARY GRAVITY SEWER	185 LF	290.00	53,650.00
0184	5768000000-N	1520	SANITARY SEWER CLEAN-OUT	4 EA	1,200.00	4,800.00
0185	5768500000-E	1520	SEWER SERVICE LINE	71 LF	52.00	3,692.00
0186	5775000000-E	1525	4' DIA UTILITY MANHOLE	122 EA	3,850.00	469,700.00
0187	5781000000-E	1525	UTILITY MANHOLE WALL 4' DIA	17 LF	450.00	7,650.00
0188	5800000000-E	1530	ABANDON 6" UTILITY PIPE	376 LF	9.75	3,666.00
0189	5801000000-E	1530	ABANDON 8" UTILITY PIPE	947 LF	10.00	9,470.00
0190	5802000000-E	1530	ABANDON 10" UTILITY PIPE	1,673 LF	15.00	25,095.00
0191	5804000000-E	1530	ABANDON 12" UTILITY PIPE	2,168 LF	19.00	41,192.00
0192	5810000000-E	1530	ABANDON 16" UTILITY PIPE	124 LF	24.00	2,976.00
0193	5816000000-N	1530	ABANDON UTILITY MANHOLE	14 EA	2,600.00	36,400.00
0194	5835700000-E	1540	16" ENCASEMENT PIPE	90 LF	104.00	9,360.00
0195	5836000000-E	1540	24" ENCASEMENT PIPE	89 LF	190.00	16,910.00
0196	5872500000-E	1550	BORE AND JACK OF *** (16")	90 LF	740.00	66,600.00
0197	5872500000-E	1550	BORE AND JACK OF *** (24")	89 LF	820.00	72,980.00

Line #	ItemNumber	Sec #	Description	Quantity Unit	Unit Bid Price	Amount Bid
0198	5912000000-N	SP	GENERIC UTILITY ITEM TEMPORARY SANITARY SEWER BY- PASS PUMPING	Lump Sum LS	34,000.00	34,000.00
0199	6000000000-E	1605	TEMPORARY SILT FENCE	9,870 LF	2.65	26,155.50
0200	6006000000-E	1610	STONE FOR EROSION CONTROL, CLASS A	760 TON	84.50	64,220.00
0201	6009000000-E	1610	STONE FOR EROSION CONTROL, CLASS B	1,205 TON	71.50	86,157.50
0202	6012000000-E	1610	SEDIMENT CONTROL STONE	1,475 TON	70.00	103,250.00
0203	6015000000-E	1615	TEMPORARY MULCHING	9 ACR	1,050.00	9,450.00
0204	6018000000-E	1620	SEED FOR TEMPORARY SEEDING	700 LB	2.10	1,470.00
0205	6021000000-E	1620	FERTILIZER FOR TEMPORARY SEED- ING	3.5 TON	850.00	2,975.00
0206	6024000000-E	1622	TEMPORARY SLOPE DRAINS	400 LF	14.70	5,880.00
0207	6029000000-E	SP	SAFETY FENCE	400 LF	2.00	800.00
0208	6030000000-E	1630	SILT EXCAVATION	1,090 CY	21.00	22,890.00
0209	6036000000-E	1631	MATTING FOR EROSION CONTROL	26,850 SY	1.90	51,015.00
0210	6037000000-E	SP	COIR FIBER MAT	1,510 SY	6.30	9,513.00
0211	6042000000-E	1632	1/4" HARDWARE CLOTH	3,840 LF	6.30	24,192.00
0212	6045000000-E	SP	*** TEMPORARY PIPE (18")	80 LF	39.00	3,120.00
0213	6070000000-N	1639	SPECIAL STILLING BASINS	9 EA	200.00	1,800.00
0214	6071012000-E	SP	COIR FIBER WATTLE	460 LF	12.00	5,520.00
0215	6071020000-E	SP	POLYACRYLAMIDE (PAM)	350 LB	10.00	3,500.00
0216	6071030000-E	1640	COIR FIBER BAFFLE	45 LF	7.35	330.75

Line #	ItemNumber	Sec #	Description	Quantity Unit	Unit Bid Price	Amount Bid
0217	6084000000-E	1660	SEEDING & MULCHING	10.5 ACR	2,200.00	23,100.00
0218	6087000000-E	1660	MOWING	6.5 ACR	210.00	1,365.00
0219	6090000000-E	1661	SEED FOR REPAIR SEEDING	150 LB	2.10	315.00
0220	6093000000-E	1661	FERTILIZER FOR REPAIR SEEDING	0.5 TON	1,200.00	600.00
0221	6096000000-E	1662	SEED FOR SUPPLEMENTAL SEEDING	250 LB	3.15	787.50
0222	6108000000-E	1665	FERTILIZER TOPDRESSING	5.75 TON	1,050.00	6,037.50
0223	6111000000-E	SP	IMPERVIOUS DIKE	300 LF	65.00	19,500.00
0224	6114500000-N	1667	SPECIALIZED HAND MOWING	20 MHR	45.00	900.00
0225	6117000000-N	SP	RESPONSE FOR EROSION CONTROL	50 EA	105.00	5,250.00
0226	6117500000-N	SP	CONCRETE WASHOUT STRUCTURE	13 EA	2,100.00	27,300.00
0227	6123000000-E	1670	REFORESTATION	5.1 ACR	3,450.00	17,595.00
0228	6126000000-E	SP	STREAMBANK REFORESTATION	0.31 ACR	3,450.00	1,069.50
0229	6132000000-N	SP	GENERIC EROSION CONTROL ITEM FABRIC INSERT INLET PROTECTION DEVICE CLEANOUT	86 EA	185.00	15,910.00
0230	6132000000-N	SP	GENERIC EROSION CONTROL ITEM FABRIC INSERT INLET PROTECTION DEVICE	43 EA	265.00	11,395.00
0231	7048500000-E	1705	PEDESTRIAN SIGNAL HEAD (16", 1 SECTION W/COUNTDOWN)	14 EA	1,000.00	14,000.00
0232	7060000000-E	1705	SIGNAL CABLE	13,955 LF	3.70	51,633.50
0233	7120000000-E	1705	VEHICLE SIGNAL HEAD (12", 3 SECTION)	45 EA	1,020.00	45,900.00
0234	7132000000-E	1705	VEHICLE SIGNAL HEAD (12", 4 SECTION)	10 EA	1,110.00	11,100.00
0235	7144000000-E	1705	VEHICLE SIGNAL HEAD (12", 5 SECTION)	14 EA	1,550.00	21,700.00

Line #	ItemNumber	Sec #	Description	Quantity Unit	Unit Bid Price	Amount Bid
0236	7264000000-E	1710	MESSENGER CABLE (3/8")	1,085 LF	4.85	5,262.25
0237	7300000000-E	1715	UNPAVED TRENCHING (***** (1, 2")	3,015 LF	7.95	23,969.25
0238	7301000000-E	1715	DIRECTIONAL DRILL (***** (2, 2")	1,905 LF	18.75	35,718.75
0239	7324000000-N	1716	JUNCTION BOX (STANDARD SIZE)	55 EA	397.00	21,835.00
0240	7360000000-N	1720	WOOD POLE	4 EA	1,110.00	4,440.00
0241	7372000000-N	1721	GUY ASSEMBLY	7 EA	570.00	3,990.00
0242	7444000000-E	1725	INDUCTIVE LOOP SAWCUT	5,200 LF	8.50	44,200.00
0243	7456000000-E	1726	LEAD-IN CABLE (***** (14-2)	13,000 LF	2.00	26,000.00
0244	7481000000-N	SP	SITE SURVEY	3 EA	851.00	2,553.00
0245	7481200000-N	SP	LUMINAIRE ARM FOR VIDEO SYSTEM	12 EA	740.00	8,880.00
0246	7481240000-N	SP	CAMERA WITHOUT INTERNAL LOOP EMULATOR PROCESSING UNIT	12 EA	3,350.00	40,200.00
0247	7481260000-N	SP	EXTERNAL LOOP EMULATOR PRO- CESSING UNIT	3 EA	9,550.00	28,650.00
0248	7481280000-N	SP	RELOCATE CAMERA SENSOR UNIT	9 EA	910.00	8,190.00
0249	7575142000-N	1736	900MHZ SERIAL SPREAD SPECTRUM RADIO	4 EA	3,600.00	14,400.00
0250	7588000000-N	SP	METAL POLE WITH SINGLE MAST ARM	16 EA	19,900.00	318,400.00
0251	7613000000-N	SP	SOIL TEST	16 EA	1,600.00	25,600.00
0252	7614100000-E	SP	DRILLED PIER FOUNDATION	144 CY	1,000.00	144,000.00
0253	7631000000-N	SP	MAST ARM WITH METAL POLE DE- SIGN	16 EA	400.00	6,400.00
0254	7636000000-N	1745	SIGN FOR SIGNALS	18 EA	510.00	9,180.00

Contract Item Sheets For C204130

Line #	ItemNumber	Sec #	Description	Quantity Unit	Unit Bid Price	Amount Bid
0255	7642200000-N	1743	TYPE II PEDESTAL WITH FOUNDATION	14 EA	1,760.00	24,640.00
0256	7684000000-N	1750	SIGNAL CABINET FOUNDATION	4 EA	1,365.00	5,460.00
0257	7696000000-N	1751	CONTROLLERS WITH CABINET (***** (TYPE 2070E, BASE MOUNTED)	4 EA	15,000.00	60,000.00
0258	7744000000-N	1751	DETECTOR CARD (TYPE 170)	34 EA	130.00	4,420.00
0259	7901000000-N	1753	CABINET BASE EXTENDER	4 EA	625.00	2,500.00
0260	7960000000-N	SP	METAL POLE FOUNDATION REMOVAL	1 EA	2,300.00	2,300.00
0261	7972000000-N	SP	METAL POLE REMOVAL	1 EA	1,700.00	1,700.00
0262	7980000000-N	SP	GENERIC SIGNAL ITEM PROTECTIVE COATING FOR PUSHBUTTON POST (BLACK)	14 EA	230.00	3,220.00
0263	7980000000-N	SP	GENERIC SIGNAL ITEM PROTECTIVE COATING FOR SINGLE MAST ARM POLE (BLACK)	16 EA	2,850.00	45,600.00

Contract Item Sheets For C204130

Line #	ItemNumber	Sec #	Description	Quantity Unit	Unit Bid Price	Amount Bid
0264	8126000000-N	414	CULVERT EXCAVATION, STA ***** (19+20.00 -L-)	Lump Sum LS	11,000.00	11,000.00
0265	8133000000-E	414	FOUNDATION CONDITIONING MATERIAL, BOX CULVERT	16 TON	86.50	1,384.00
0266	8196000000-E	420	CLASS A CONCRETE (CULVERT)	41.7 CY	1,500.00	62,550.00
0267	8245000000-E	425	REINFORCING STEEL (CULVERT)	3,911 LB	1.70	6,648.70

Contract Item Sheets For C204130

Line #	ItemNumber	Sec #	Description	Quantity	Unit	Unit Bid Price	Amount Bid
0268	8802014000-E	SP	SOLDIER PILE RETAINING WALLS	935	SF	170.00	158,950.00

Line #	ItemNumber	Sec #	Description	Quantity Unit	Unit Bid Price	Amount Bid
0269	8017000000-N	SP	CONSTRUCTION, MAINTENANCE, & REMOVAL OF TEMP ACCESS AT STA ***** (14+94.00 -L-)	Lump Sum LS	62,500.00	62,500.00
0270	8035000000-N	402	REMOVAL OF EXISTING STRUCTURE AT STATION ***** (14+94.00 -L-)	Lump Sum LS	49,600.00	49,600.00
0271	8065000000-N	SP	ASBESTOS ASSESSMENT	Lump Sum LS	2,500.00	2,500.00
0272	8121000000-N	412	UNCLASSIFIED STRUCTURE EXCAVA- TION AT STATION ***** (14+94.00 -L-)	Lump Sum LS	10,000.00	10,000.00
0273	8175000000-E	420	CLASS AA CONCRETE (BRIDGE)	43.7 CY	851.00	37,188.70
0274	8182000000-E	420	CLASS A CONCRETE (BRIDGE)	59.4 CY	851.00	50,549.40
0275	8210000000-N	422	BRIDGE APPROACH SLABS, STATION ***** (14+94.00 -L-)	Lump Sum LS	29,500.00	29,500.00
0276	8217000000-E	425	REINFORCING STEEL (BRIDGE)	10,862 LB	1.70	18,465.40
0277	8224000000-E	425	EPOXY COATED REINFORCING STEEL (BRIDGE)	1,092 LB	1.70	1,856.40
0278	8328200000-E	450	PILE DRIVING EQUIPMENT SETUP FOR *** STEEL PILES (HP 12 X 53)	14 EA	360.00	5,040.00
0279	8364000000-E	450	HP12X53 STEEL PILES	980 LF	91.00	89,180.00
0280	8482000000-E	460	THREE BAR METAL RAIL	92.2 LF	295.00	27,199.00
0281	8505000000-E	460	VERTICAL CONCRETE BARRIER RAIL	100 LF	182.00	18,200.00
0282	8608000000-E	876	RIP RAP CLASS II (2'-0" THICK)	285 TON	23.00	6,555.00
0283	8622000000-E	876	GEOTEXTILE FOR DRAINAGE	320 SY	8.00	2,560.00
0284	8657000000-N	430	ELASTOMERIC BEARINGS	Lump Sum LS	5,500.00	5,500.00

Contract Item Sheets For C204130

Line #	ItemNumber	Sec #	Description	Quantity Unit	Unit Bid Price	Amount Bid
0285	8753200000-E	430	3'-0" X 3'-3" PRESTRESSED CONC BOX BEAMS	1,100 LF	329.00	361,900.00

TOTAL AMOUNT OF BID FOR ENTIRE PROJECT

\$14,032,805.00

0827/Dec12/Q326971.338/D1250663908000/E285

C204130

Contract No. _____
County MACON

Rev. 1-16-18

**EXECUTION OF CONTRACT
NON-COLLUSION, DEBARMENT AND GIFT BAN CERTIFICATION**

CORPORATION

The Contractor declares (or certifies, verifies, or states) under penalty of perjury under the laws of the United States that neither he, nor any official, agent or employee has entered into any agreement, participated in any collusion, or otherwise taken any action which is in restraint of free competitive bidding in connection with this Contract, that the Contractor has not been convicted of violating *N.C.G.S. § 133-24* within the last three years, and that the Contractor intends to do the work with its own bonafide employees or subcontractors and did not bid for the benefit of another contractor.

By submitting this Execution of Contract, Non-Collusion and Debarment Certification, the Contractor is certifying his status under penalty of perjury under the laws of the United States in accordance with the Debarment Certification attached, provided that the Debarment Certification also includes any required statements concerning exceptions that are applicable.

N.C.G.S. § 133-32 and Executive Order 24 prohibit the offer to, or acceptance by, any State Employee of any gift from anyone with a contract with the State, or from any person seeking to do business with the State. By execution of any response in this procurement, you attest, for your entire organization and its employees or agents, that you are not aware that any such gift has been offered, accepted, or promised by any employees of your organization.

SIGNATURE OF CONTRACTOR

Buchanan and Sons Inc

Full name of Corporation

P.O. Box 123, Whittier, NC 28789

Address as Prequalified

Attest  By 
Secretary / ~~Assistant Secretary~~ / ~~President~~ / ~~Vice President~~ / ~~Director~~ / ~~Executive Director~~
Select appropriate title

President / Vice President / ~~Director~~ / ~~Executive Director~~
Select appropriate title

Carl Buchanan, Jr.

Print or type Signer's name

Christopher Buchanan

Print or type Signer's name



DEBARMENT CERTIFICATION

Conditions for certification:

1. The prequalified bidder shall provide immediate written notice to the Department if at any time the bidder learns that his certification was erroneous when he submitted his debarment certification or explanation filed with the Department, or has become erroneous because of changed circumstances.
2. The terms *covered transaction, debarred, suspended, ineligible, lower tier covered transaction, participant, person, primary covered transaction, principal, proposal, and voluntarily excluded*, as used in this provision, have the meanings set out in the Definitions and Coverage sections of the rules implementing Executive Order 12549. A copy of the Federal Rules requiring this certification and detailing the definitions and coverages may be obtained from the Contract Officer of the Department.
3. The prequalified bidder agrees by submitting this form, that he will not knowingly enter into any lower tier covered transaction with a person who is debarred, suspended, declared ineligible, or voluntarily excluded from participation in NCDOT contracts, unless authorized by the Department.
4. For Federal Aid projects, the prequalified bidder further agrees that by submitting this form he will include the Federal-Aid Provision titled *Required Contract Provisions Federal-Aid Construction Contract (Form FHWA PR 1273)* provided by the Department, without subsequent modification, in all lower tier covered transactions.
5. The prequalified bidder may rely upon a certification of a participant in a lower tier covered transaction that he is not debarred, suspended, ineligible, or voluntarily excluded from the covered transaction, unless he knows that the certification is erroneous. The bidder may decide the method and frequency by which he will determine the eligibility of his subcontractors.
6. Nothing contained in the foregoing shall be construed to require establishment of a system of records in order to render in good faith the certification required by this provision. The knowledge and information of a participant is not required to exceed that which is normally possessed by a prudent person in the ordinary course of business dealings.
7. Except as authorized in paragraph 6 herein, the Department may terminate any contract if the bidder knowingly enters into a lower tier covered transaction with a person who is suspended, debarred, ineligible, or voluntarily excluded from participation in this transaction, in addition to other remedies available by the Federal Government.

DEBARMENT CERTIFICATION

The prequalified bidder certifies to the best of his knowledge and belief, that he and his principals:

- a. Are not presently debarred, suspended, proposed for debarment, declared ineligible, or voluntarily excluded from covered transactions by any Federal department or agency;
- b. Have not within a three-year period preceding this proposal been convicted of or had a civil judgment rendered against them for commission of fraud or a criminal offense in connection with obtaining, attempting to obtain, or performing a public (Federal, State or local) transaction or contract under a public transaction; violation of Federal or State antitrust statutes or commission of embezzlement, theft, forgery, bribery, falsification or destruction of records; making false statements; or receiving stolen property;
- c. Are not presently indicted for or otherwise criminally or civilly charged by a governmental entity (Federal, State or local) with commission of any of the offenses enumerated in paragraph b. of this certification; and
- d. Have not within a three-year period preceding this proposal had one or more public transactions (Federal, State or local) terminated for cause or default.
- e. Will submit a revised Debarment Certification immediately if his status changes and will show in his bid proposal an explanation for the change in status.

If the prequalified bidder cannot certify that he is not debarred, he shall provide an explanation with this submittal. An explanation will not necessarily result in denial of participation in a contract.

Failure to submit a non-collusion and debarment certification will result in the prequalified bidder's bid being considered non-responsive.

Check here if an explanation is attached to this certification.

Contract No. **C204130**

County (ies): **Macon**

ACCEPTED BY THE
DEPARTMENT OF TRANSPORTATION

DocuSigned by:

Ronald E. Davenport, Jr.

F81B6038A47A442...

Contract Officer

12/16/2018

Date

Execution of Contract and Bonds
Approved as to Form:

DocuSigned by:

Scott Beaver

55FE7B40AA93401...

Attorney General

12/16/2018

Date

Signature Sheet (Bid - Acceptance by Department)

Contract No.
County

C204130

Macon

Rev 5-17-11

CONTRACT PAYMENT BOND

Date of Payment Bond Execution December 7, 2018
Name of Principal Contractor Buchanan and Sons, Inc.
Name of Surety: Hudson Insurance Company
Name of Contracting Body: North Carolina Department of Transportation
Raleigh, North Carolina
Amount of Bond: \$14,032,805.00
Contract ID No.: C204130
County Name: Macon

KNOW ALL MEN BY THESE PRESENTS, That we, the PRINCIPAL CONTRACTOR (hereafter, PRINCIPAL) and SURETY above named, are held and firmly bound unto the above named Contracting Body, hereinafter called the Contracting Body, in the penal sum of the amount stated above for the payment of which sum well and truly to be made, we bind ourselves, our heirs, executors, administrators, and successors, jointly and severally, firmly by these presents.

THE CONDITION OF THIS OBLIGATION IS SUCH, that whereas the principal entered into a certain contract with the Contracting Body, numbered as shown above and hereto attached:

NOW THEREFORE, if the principal shall promptly make payment to all persons supplying labor and material in the prosecution of the work provided for in said contract, and any and all duly authorized modifications of said contract that may hereafter be made, notice of which modifications to the surety being hereby waived, then this obligation to be void; otherwise to remain in full force and virtue.

IN WITNESS WHEREOF, the above-bound parties have executed this instrument under their several seals on the date indicated above, the name and corporate seal of each corporate party being hereto affixed and these presents duly signed by its undersigned representative, pursuant to authority of its governing body.

Contract No. C204130
County Macon

Rev 5-17-11

CONTRACT PAYMENT BOND

Hudson Insurance Company

Print or type Surety Company Name



Affix Seal of Surety Company

By **Karen K. Beard**

Print, stamp or type name of Attorney-in-Fact

Handwritten signature of Karen K. Beard in cursive script.

Signature of Attorney-in-Fact

Handwritten signature of Susan R. Fussell in cursive script.

Signature of Witness

Susan R. Fussell

Print or type Signer's name

552-B New Haw Creek Rd., Asheville, NC 28805

Address of Attorney-in-Fact

Contract No.
County

C204130

Macon

Rev 5-17-11

CONTRACT PAYMENT BOND

CORPORATION

SIGNATURE OF CONTRACTOR (Principal)

Buchanan and Sons, Inc.

Full name of Corporation

P. O. Box 123, Whittier, NC 28789

Address as prequalified

By 
Signature of ~~President~~ Vice President ~~Assistant Vice President~~
Select appropriate title

Christopher S. Buchanan

Print or type Signer's name



Affix Corporate Seal

Attest

Signature of ~~Secretary~~ Assistant Secretary
Select appropriate title

Carl S. Buchanan, Jr.

Print or type Signer's name

Contract No.
County

C204130

MACON

Rev 5-17-11

Bond #: ASA1824-11149

CONTRACT PERFORMANCE BOND

Date of Performance Bond Execution: December 7, 2018
Name of Principal Contractor: Buchanan and Sons, Inc.
Name of Surety: Hudson Insurance Company
Name of Contracting Body: North Carolina Department of Transportation
Raleigh, North Carolina
Amount of Bond: \$14,032,805.00
Contract ID No.: C204130
County Name: Macon

KNOW ALL MEN BY THESE PRESENTS, That we, the PRINCIPAL CONTRACTOR (hereafter, PRINCIPAL) and SURETY above named, are held and firmly bound unto the above named Contracting Body, hereinafter called the Contracting Body, in the penal sum of the amount stated above for the payment of which sum well and truly to be made, we bind ourselves, our heirs, executors, administrators, and successors, jointly and severally, firmly by these presents.

THE CONDITION OF THIS OBLIGATION IS SUCH, that whereas the principal entered into a certain contract with the Contracting Body, numbered as shown above and hereto attached:

NOW THEREFORE, if the principal shall well and truly perform and fulfill all the undertakings, covenants, terms, conditions, and agreements of said contract during the original term of said contract and any extensions thereof that may be granted by the Contracting Body, with or without notice to the Surety, and during the life of any guaranty required under the contract, and shall also well and truly perform and fulfill all the undertakings, covenants, terms, conditions, and agreements of any and all duly authorized modifications of said contract that may hereafter be made, notice of which modifications to the surety being hereby waived, then this obligation to be void; otherwise to remain in full force and virtue.

IN WITNESS WHEREOF, the above-bound parties have executed this instrument under their several seals on the date indicated above, the name and corporate seal of each corporate party being hereto affixed and these presents duly signed by its undersigned representative, pursuant to authority of its governing body.

Contract No.
County

C204130

Macon

Rev 5-17-11

CONTRACT PERFORMANCE BOND

Hudson Insurance Company

Print or type Surety Company Name



Affix Seal of Surety Company

By **Karen K. Beard**

Print, stamp or type name of Attorney-in-Fact

A handwritten signature in cursive script that reads 'Karen K. Beard'.

Signature of Attorney-in-Fact

A handwritten signature in cursive script that reads 'Susan R. Fussell'.

Signature of Witness

Susan R. Fussell

Print or type Signer's name

552-B New Haw Creek Rd., Asheville, NC 28805

Address of Attorney-in-Fact

Contract No.
County

C204130

Macon

Rev 5-17-11

CONTRACT PERFORMANCE BOND

CORPORATION

SIGNATURE OF CONTRACTOR (Principal)

Buchanan and Sons, Inc.

Full name of Corporation

P. O. Box 123, Whittier, NC 28789

Address as prequalified

By 
Signature of ~~President~~ Vice President ~~Assistant Vice President~~
Select appropriate title

Christopher S. Buchanan

Print or type Signer's name



Affix Corporate Seal

Attest

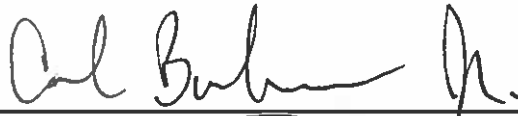

Signature of Secretary ~~Assistant Secretary~~
Select appropriate title

Carl S. Buchanan, Jr.

Print or type Signer's name



POWER OF ATTORNEY

KNOW ALL MEN BY THESE PRESENTS: That HUDSON INSURANCE COMPANY, a corporation of the State of Delaware, with offices at 100 William Street, New York, New York, 10038, has made, constituted and appointed, and by these presents, does make, constitute and appoint

Karen K. Beard and Wallace N. Hyde of the State of North Carolina

its true and lawful Attorney(s)-in-Fact, at New York, New York, each of them alone to have full power to act without the other or others, to make, execute and deliver on its behalf, as Surety, bonds and undertakings given for any and all purposes, also to execute and deliver on its behalf as aforesaid renewals, extensions, agreements, waivers, consents or stipulations relating to such bonds or undertakings provided, however, that no single bond or undertaking shall obligate said Company for any portion of the penal sum thereof in excess of the sum of Twenty Million Dollars (\$20,000,000.00).

Such bonds and undertakings when duly executed by said Attorney(s)-in-Fact, shall be binding upon said Company as fully and to the same extent as if signed by the President of said Company under its corporate seal attested by its Secretary.

In Witness Whereof, HUDSON INSURANCE COMPANY has caused these presents to be of its Senior Vice President thereunto duly signed on this 6th day of December, 2018 at New York, New York.



Attest: [Signature] Dina Daskalakis Corporate Secretary

HUDSON INSURANCE COMPANY

By: [Signature] Michael P. Cifone Senior Vice President

STATE OF NEW YORK COUNTY OF NEW YORK SS.

On the 6th day of December, 2018 before me personally came Michael P. Cifone to me known, who being by me duly sworn did depose and say that he is a Senior Vice President of HUDSON INSURANCE COMPANY, the corporation described herein and which executed the above instrument, that he knows the seal of said Corporation, that the seal affixed to said instrument is such corporate seal, that it was so affixed by order of the Board of Directors of said Corporation, and that he signed his name thereto by the order of said Corporation.

(Notarial Seal)

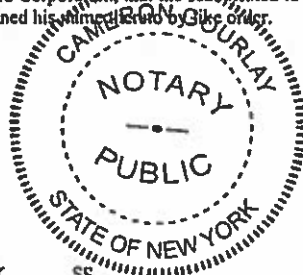

[Signature] CAMERON GOURLAY Notary Public, State of New York No. 01GO6372305 Qualified in New York County Commission Expires June 4, 2022

CERTIFICATION

STATE OF NEW YORK COUNTY OF NEW YORK SS.

The undersigned Dina Daskalakis hereby certifies:

That the original resolution, of which the following is a true and correct copy, was duly adopted by unanimous written consent of the Board of Directors of Hudson Insurance Company dated July 27th, 2007, and has not since been revoked, amended or modified:

"RESOLVED, that the President, the Executive Vice Presidents, the Senior Vice Presidents and the Vice Presidents shall have the authority and discretion, to appoint such agent or agents, or attorney or attorneys-in-fact, for the purpose of carrying on this Company's surety business, and to empower such agent or agents, or attorney or attorneys-in-fact, to execute and deliver, under this Company's seal or otherwise, bonds obligations, and recognizances, whether made by this Company as surety thereon or otherwise, indemnity contracts, contracts and certificates, and any and all other contracts and undertakings made in the course of this Company's surety business, and renewals, extensions, agreements, waivers, consents or stipulations regarding undertakings so made; and

FURTHER RESOVLED, that the signature of any such Officer of the Company and the Company's seal may be affixed by facsimile to any power of attorney or certification given for the execution of any bond, undertaking, recognizance, contract of indemnity or other written obligation in the nature thereof or related thereto, such signature and seal when so used whether heretofore or hereafter, being hereby adopted by the Company as the original signature of such officer and the original seal of the Company, to be valid and binding upon the Company with the same force and effect as though manually affixed."

THAT the above and foregoing is a full, true and correct copy of Power of Attorney issued by said Company, and of the whole of the original and that the said Power of Attorney is still in full force and effect and has not been revoked, and furthermore that the Resolution of the Board of Directors, set forth in the said Power of Attorney is now in force.

In Witness Whereof, I signed the hand of the undersigned and the seal of said Corporation this 7th day of December, 2018.

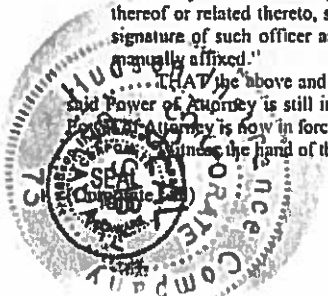

By: [Signature] Dina Daskalakis, Corporate Secretary